









Pricelist

2026

unleash the full potential



Attachments to suit your needs

Product groups		Type of machine*				Sector					Page
		 Forklift	 Skid steer loader	 Telehandler	 Tractor loader	 Agri	 Construction	 Industry	 Food & beverage	 Paper handling	
1.	Sideshifters	✓	✓	✓	✓	✓	✓	✓	✓	✓	11
2.	Fork positioners	✓	✓	✓		✓	✓	✓	✓	✓	23
3.	Multi-fork positioners	✓		✓				✓	✓		79
4.	Rotators & box rotators	✓	✓	✓		✓	✓	✓	✓		87
5.	Roll clamps	✓	✓	✓						✓	99
6.	Clamps	✓					✓	✓			113
7.	Bale clamps	✓	✓	✓			✓	✓		✓	133
8.	Appliance and carton clamps	✓					✓	✓			165
9.	Concrete block clamps	✓	✓	✓			✓	✓			179
10.	Push-pulls	✓					✓	✓	✓		185
11.	Load extenders	✓					✓	✓	✓		193
12.	Load stabilisers	✓					✓	✓	✓		197
13.	Skips	✓	✓	✓		✓	✓	✓	✓	✓	203
14.	Scoops	✓	✓	✓		✓	✓	✓			209
15.	Booms	✓		✓				✓		✓	215
16.	Crane jibs	✓		✓			✓	✓			219
17.	Fork-mounted lifting hook	✓	✓	✓	✓	✓	✓	✓			225
18.	Big bag handlers	✓		✓	✓	✓	✓	✓			229
19.	Snow ploughs	✓		✓			✓	✓			233
20.	Yard scrapers	✓		✓			✓	✓			237
21.	Fork-mounted drum handlers and drum tippers	✓	✓	✓	✓	✓	✓	✓			241
22.	Forklift cages	✓						✓			245
23.	Forks & fork extensions	✓	✓	✓	✓	✓	✓	✓	✓	✓	249
24.	Options, accessories and hydraulic parts										265

*The attachment connection is different based on the carriage brand.

Contents

	Product group	Model	Page
1	Sideshifters		11
1.1	Sideshifters ISO/FEM 2 with sliding pads	SHP	12
1.2	Sideshifters ISO/FEM 3 with sliding pads	SHP	13
1.3	Sideshifters ISO/FEM 1–2 with sliding pads	TRF	14
1.4	Sideshifters ISO/FEM 3 with sliding pads	TRF	15
1.5	Sideshifters ISO/FEM 3–4 with sliding pads	TRF	16
1.6	Sideshifters ISO/FEM 4 with sliding pads	TRF	17
1.7	Dual and triple sideshifters	2DL–3DL	18
1.8	Standard hose kit for separate sideshifter		19
1.9	Load backrest for sideshifters	LBR	20
1.10	Technical data		21
2	Fork positioners		23
2.1	Fork positioner with FEM fork carriers without sideshifter	PH	24
2.2	Fork positioner with FEM fork carriers with sideshifter	PH-T	26
2.3	Fork positioner with FEM fork carriers without sideshifter	PH.SIN	28
2.4	Fork positioner with FEM fork carriers with sideshifter	PH-T.SIN	29
2.5	Fork positioner with bar-mounted FEM fork carriers without sideshifter	PL	30
2.6	Fork positioner with bar-mounted FEM fork carriers with separate sideshifter	PL-T	32
2.7	Fork positioner with FEM fork carriers without sideshifter	PK	34
2.8	Fork positioner with FEM fork carriers without sideshifter	PK.SIN	36
2.9	Fork positioner with FEM fork carriers with separate sideshifter	PK-TS	38
2.10	Fork positioner with FEM fork carriers with separate sideshifter	PK-TS.SIN	40
2.11	Fork positioner with forks without sideshifter	PKF	42
2.12	Fork positioner with forks without sideshifter	PKF.SIN	44
2.13	Fork positioner with forks with separate sideshifter	PKF-TS	46
2.14	Fork positioner with forks with separate sideshifter	PKF-TS.SIN	48
2.15	Fork positioner with pin-type forks and valve block sideshifter	PJ-T	50
2.16	Fork positioner with bar-mounted FEM-fork carriers with valve block sideshifter	PJA-T	52
2.17	Integrated fork positioner with pin-type forks and valve block sideshifter	PJI-T	54
2.18	Fork positioner with pin-type forks without sideshifter	PF	56
2.19	Fork positioner with pin-type forks with separate sideshifter	PF-T	58
2.20	Heavy-duty fork positioner with bar-mounted FEM fork carriers without sideshifter	PFA	60
2.21	Heavy-duty fork positioner with bar-mounted FEM fork carriers with separate sideshifter	PFA-T	62
2.22	Integrated high-capacity fork positioner with welded forks	PR & PRI	64
2.23	High-capacity fork positioner with FEM fork carriers without sideshifter	PRA	65
2.24	Wide-opening fork positioner with welded forks	WF	66
2.25	Wide-opening fork positioner with FEM fork carriers	WA	68
2.26	Wide-opening fork positioner with FEM fork carriers and valve block sideshifter	WA-T	70
2.27	Rotating fork positioner with FEM fork carriers 360°	PHR	72
2.28	Rotating fork positioner with pin-type forks 360°	PFR	73
2.29	Rotating fork clamp 360°	HFR	74
2.30	Technical data		76
2.31	Standard hose kit for separate sideshifter		77

	Product group	Model	Page
3	Multi-fork positioners		79
3.1	Four-fork positioner for multi-pallets	DPS	80
3.2	Six-fork positioner for multi-pallets	TPS	82
3.3	Technical data		84
4	Rotators & box rotators		87
4.1	360° Rotators	PRC	88
4.2	Rotator with sidershifter 360°	PRC-T	89
4.3	Rotator without sidershifter 360°, marine version	PRC-Z	90
4.4	Box rotator 360°	PRC-DA	91
4.5	Rotator with hydraulic bin retainer 360°	RBC	92
4.6	Plastic container rotator 360°	RLC	93
4.7	Box rotator 180°	RLW	94
4.8	Plastic container rotator 150° for agriculture	RLC-A	96
4.9	Technical data		97
5	Roll clamps		99
5.1	Rotating paper roll clamp 360°	CR	100
5.2	Rotating paper roll clamp – split arms 360°	CR-S	103
5.3	Rotating tyre clamp 360°	CR-TY	106
5.4	Tilting paper roll clamp 90°	CT	107
5.5	Tilting paper roll clamp – split arm 90°	CT-S	108
5.6	Rotating 360° and tilting paper roll clamp 90°	CC	109
5.7	Non-rotating paper roll clamp	CPS-B	110
5.8	Technical data		111
6	Clamps		113
6.1	Fork clamp	HF-T	114
6.2	Rotating fork clamp 360°	HFR	116
6.3	Rotating 90° pivoting fork clamp hand-operated	HP-T	118
6.4	Rotating 90° pivoting fork clamp manually operated 360°	HPR	119
6.5	Load clamp without arms	H	120
6.6	Rotating load clamp 360° without arms	HR	122
6.7	Basket clamp with rubber-faced arms	HX-T	124
6.8	Basket clamp with articulating rubber-faced arms	HOX	125
6.9	Drum clamp	HD	126
6.10	Rotating drum clamp 360°	HDR	127
6.11	Tilting drum clamp 180°	HZ	128
6.12	Pallet inverter clamp 360°	HI	129
6.13	Load clamps for foam rubber blocks	HY	130
6.14	Technical data		131
7	Bale clamps		133
7.1	Bale clamps	HB-T	134
7.2	Recycling clamps	HB-T CDW.01	140
7.3	Pulp bale clamps	HBC-T	148
7.4	Rotating bale clamp 360°	HBR	156

Contents

	Product group	Model	Page
7.5	Multi-purpose clamp with rubber-faced arms	HBG-T	159
7.6	Open control valve	OCV	161
7.7	Technical data		162
8	Appliance and carton clamps		165
8.1	Appliance and carton clamp – single articulating pads	HEWA-T	166
8.2	Intelligent appliance clamp	HEXA	171
8.3	Appliance and carton clamp – rigid pads	HEF-T	172
8.4	Appliance and carton clamp – tilting pads	HETP	173
8.5	Digital dynamometer	DD	174
8.6	Pressure control	PC	175
8.7	Technical data		176
9	Concrete block clamps		179
9.1	Concrete block clamp – self-compensating arm pads	HC	180
9.2	Concrete block clamp – articulated arm pads	HCA	181
10.3	Technical data		182
10	Push-pulls		185
10.1	Push-pull	PP	186
10.2	Push-pull with separate sideshifter	PPTS	187
10.3	Push-pull fork-mounted	PP-I	188
10.4	Load push	LP	189
10.5	Load push fork-mounted	LP-I	190
10.6	Technical data		191
11	Load extenders		193
11.1	Load extender	ES	194
11.2	Technical data		195
12	Load stabilisers		197
12.1	Load stabiliser	SCA	198
12.2	Technical data		200
13	Skips		203
13.1	Roll-forward skip	KPC	204
13.2	Bottom-emptying skip	BES	206
14	Scoops		209
14.1	Hydraulic scoop	B	210
14.2	Hydraulic scoop – fork-mounted	HS	211
14.3	Mechanical scoop – fork mounted	MS	212
15	Booms		215
15.1	Coil boom	SP	216
15.2	Carpet pole	AT	217
16	Crane jibs		219
16.1	Carriage-mounted crane jib	GAB	220
16.2	Fork-mounted crane jib manual	GAB1	221
16.3	Fork-mounted crane jib manual telescopic	GAB2	222
16.4	Fork-mounted crane jib manual telescopic, adjustable	GAB3	223

	Product group	Model	Page
17	Fork-mounted lifting hook		225
17.1	Fork-mounted lifting hook	FMH	226
17.2	Fork-mounted shunting aid	SHA	227
18	Big-bag handlers		229
18.1	Fork-mounted big-bag handler	BBH	230
19	Snow ploughs		233
19.1	Snow plough	SNO	234
20	Yard scrapers		237
20.1	Yard scraper	YSC	238
21	Fork-mounted drum handlers and drum tipper		241
21.1	Fork-mounted drum handler	DC	242
21.2	Fork-mounted mechanical drum tipper	DR	243
22	Forklift cages		245
22.1	Forklift cage	SKG	246
23	Forks & fork extensions		249
23.1	Guide		250
23.2	Reach forks	RHF	252
23.3	IFORKS-32 weighing forks	WGF-L	254
23.4	Weighing carriages	ICP-32	255
23.5	Fork extension – closed bottom	EXT	256
23.6	Fork extension – open bottom	EXT2	257
23.7	Slip-on-fork arm with rubber-faced pads	CPG	258
23.8	Slip-on-fork arm for concrete blocks	CBA	259
23.9	Slip-on-fork arm for drums	CF	260
23.10	Anti-slip coating	COA	261
23.11	Fork carriage profiles	FCP	262
24	Options, accessories and hydraulic parts		265
24.1	Wireless fork camera system	WFCS	266
24.2	Open control valve	OCV	267
24.3	Digital dynamometer	DD	268
24.4	Pressure control	PC	269
24.5	Dynamometer	STD	270
24.6	Add-on prices		271
24.7	Set quick-release		272
24.8	Hydraulic valves and components	VAL	273
24.9	Universal kit with hydraulic hose reel for extra functionality	RLS	288
24.10	Hose reel and bracket	RLS2	289



About CAM attachments®

Active all over the world

Drawing on more than 50 years of experience, we design and produce a wide range of reliable, high-quality attachments. We have two production plants: one in Italy and one in China. These strategic locations allow us to meet all industry standards and serve our customers in the best possible way. From these plants, we ship to over 80 countries worldwide.

Wide range of attachments

At CAM attachments, we focus on creating attachments that fit the unique needs of our customers. By studying their processes, we have developed a comprehensive range of attachments for various industries and machines. Our range includes forks, fork positioners, multi-fork positioners, fork clamps, bale clamps, 180°- and 360°-rotating clamps, carton clamps, paper roll clamps, sidershifters, skips, crane jibs, snow ploughs, and more.

For key industries

With flexibility and experience, we create products for key industries like logistics, construction, food and beverage, agriculture, paper handling, recycling, white goods, manufacturing and foundries.

For various machines

Our attachments are compatible with a variety of machines such as forklifts, skid steer loaders, telehandlers and tractor loaders.

Excellent after-sales support

Along with attachments, we have an extensive range of spare parts in stock. Our team of skilled engineers provides full after-sales support with on-site repairs and maintenance, as well technical support over the phone.

Our history

1970

Established in Grignasco (Novara, Northern Italy)

2001

- **New ownership** under the Garofletti – De Luca family
- New location in Marano Ticino

2002

Launch of **CAM System**, a dedicated brand focused on forklift attachments

2007

Introduction of a **new range of clamps** based on the development of a new extruded steel profile

2009

Supply agreement with TVH Group

2012

- Acquisition by **TVH Group**
- New industrial development plan focusing on the integration of CAM System products into TVH's global structure

2013

- **New investment plan** approved for factory expansion and quality improvements
- Worldwide stockholding introduced through TVH branches

2017

Rebranding of CAM System to **CAM attachments** with new logo and style to reflect the upgraded range

2018

Production plant in **Xiamen**, China opens

2019

Launch of **CAM attachments S-line**, a range of basic attachments at competitive prices

2024

Launch of PK-Fork Positioner Family

2025

Extension of the Plant in Marano Ticino

Points of interest

Various FEM mounting classes

We supply our attachments as standard in FEM mounting class II A, III A or IV A. As such, height, ground clearance, thickness, centre of gravity and weight refer to these classes. In addition, we supply FEM class II B, III B or IV B on request at no extra cost. Mounting types not included in the above categories, however, are considered special and are only available on request at extra cost.

Hydraulic best practices

All hydraulic attachments in this catalogue, except sidershifters, come with pre-regulated non-return and maximum pressure valves. For the best performance and long-lasting use, ensure that oil supply lines have an internal diameter of at least 10 mm for capacities up to 2500 kg, and 12–13 mm for heavier loads. Elbows, connectors and constricted passages should be kept to an absolute minimum.

Rotating attachments

Rotating attachments are supplied with a 0°–2° forward angle on the truck's chassis. A 4° angle is available on request.

General information

The capacities, dimensions, and performance shown are for reference only and are intended for product development purposes. CAM S.r.l. reserves the right to make modifications without notice. Stated capacities apply to the attachments only.

Be aware

To ensure the safe lifting of loads it is vital to know the residual capacity of a forklift with any attachment. Factors like load type, work conditions, tyres, and mast type can all impact the final capacity, so these should be carefully considered.

Capacity Calculator

Find out your forklift's residual capacity in just 1 minute

To lift loads safely, it's essential to know a forklift's residual capacity with any attachment. Our easy-to-use tool takes the hassle out of these calculations.

Simply enter the forklift, attachment and load specifications as instructed and the tool will calculate the residual capacity for you. Once generated you can easily download the results to keep on record or share with your team.

Always use the Capacity Calculator to check compatibility before buying a new attachment.



Scan the QR code or go to camattachments.com to get started!

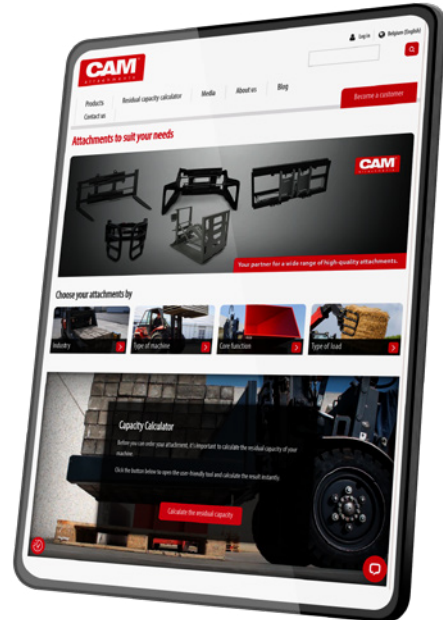

Learn how to calculate valveblock sideshift stroke

Sideshifting makes forklifts more versatile and easier to manoeuvre. Forklifts have either integrated or separate sideshifting. The valveblock sideshift function uses the same cylinder to control the opening and closing of a clamp. The shift decreases proportionally to zero when the cylinder is fully extended (clamp fully open) or fully retracted (clamp fully closed).

To check the sideshift stroke available in a clamp, we define:

- A = maximum opening
- B = minimum opening
- C = width of the load

The calculation is as follows:

$$A - C =$$

$$C - B =$$

The smaller of these two values is the total sideshift available. Note that the valveblock sideshift function doesn't change the weight (centre of gravity) and thickness values.

The separate sideshift function uses a separate cylinder with a relative sliding system at the back of the clamp. The stroke has always constant 100 + 100 mm or 150 + 150 mm, regardless of the position of the cylinder. This type increases the clamp's weight (centre of gravity) and thickness values.

Carriage dimensions

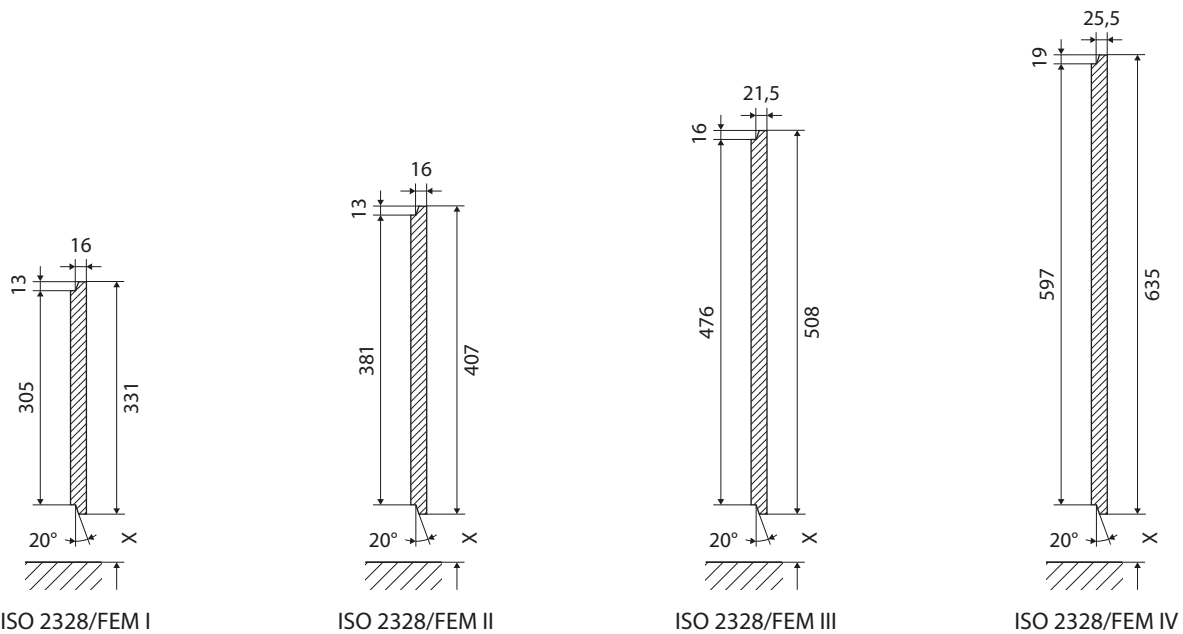

ISO 2328/FEM	Forklift capacity	X
	kg/mm	mm
I A	From 0 to 999/400	76
I B		114
II A	From 1000 to 2500/500	76
II B		152
III A	From 2501 to 4999/500	76
III B		203
IV A	From 5000 to 8000/600	127
IV B		254
V A	From 8001 to 10999/600	127
V B		257





1. Sideshifters

Sideshifters are one of the most commonly used lifting attachments. They enable precise, lateral load movement for quicker, more accurate lifting and placement. These attachments also help reduce handling time, minimize product or pallet damage, and enhance maneuverability – even in tight spaces.

SHP

2500 kg

Sideshifters ISO/FEM 2 with sliding pads

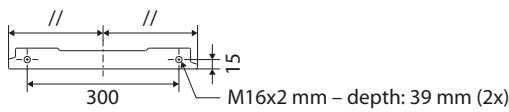
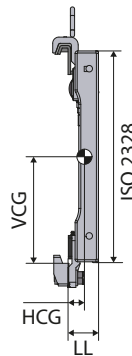
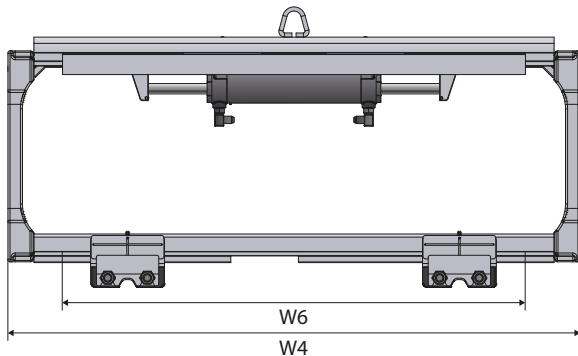

Product info

- W6 – Minimum carriage width
- Total sideshifter stroke: 100 + 100 mm



Model	Capacity	W4	W6	LL	HCG	VCG	Weight	ISO 2328	RRP
	kg/mm								mm
SHP225.080P.CD1	2500/500	800	780	58	23	224	42	2	430
SHP225.090P.CD1	2500/500	900	780	58	23	224	46	2	430
★ SHP225.092P.CD1	2500/500	920	780	58	23	224	46	2	430
SHP225.094P.CD1	2500/500	940	780	58	23	224	47	2	430
★ SHP225.098P.CD1	2500/500	980	780	58	23	224	48	2	430
★ SHP225.100P.CD1	2500/500	1000	780	58	23	224	49	2	430
★ SHP225.102P.CD1	2500/500	1020	780	58	23	224	49	2	430
★ SHP225.104P.CD1	2500/500	1040	780	58	23	224	50	2	430
SHP225.107P.CD1	2500/500	1070	780	58	23	224	51	2	430
★ SHP225.110P.CD1	2500/500	1100	780	58	23	224	52	2	430
★ SHP225.115P.CD1	2500/500	1150	780	58	23	224	54	2	430
★ SHP225.125P.CD1	2500/500	1250	980	58	23	224	57	2	650
★ SHP225.140P.CD1	2500/500	1400	980	58	23	224	67	2	730

★ Suggested selection

Advantages

- Reinforced frame corners
- Extremely strong, one-piece top bar
- Cylinder mounted via single spring pin connection
- User-friendly design
- Expertly manufactured
- Superior mechanical strength

Available on request

- Load backrest (see page 20)

Sideshifters ISO/FEM 3 with sliding pads

SHP
3500 kg

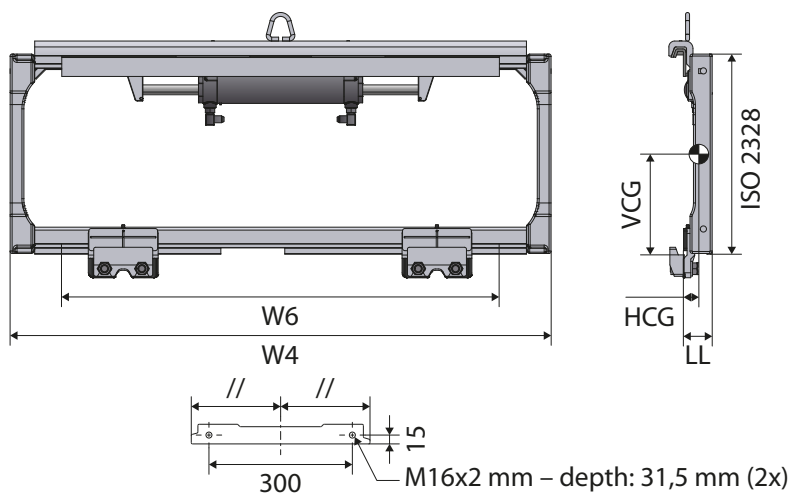

Product info

- W6 – Minimum carriage width
- Total sideshifter stroke: 100 + 100 mm



Model	Capacity	W4	W6	LL	HCG	VCG	Weight	ISO 2328	RRP
	kg/mm	mm	mm	mm	mm	mm	kg		Euro
★ SHP335.100P.CD1	3500/500	1000	980	68	29	281	67	3	600
★ SHP335.102P.CD1	3500/500	1020	980	68	29	281	67	3	600
★ SHP335.107P.CD1	3500/500	1070	980	68	29	282	70	3	610
★ SHP335.110P.CD1	3500/500	1100	980	68	29	282	71	3	610
★ SHP335.115P.CD1	3500/500	1150	980	68	29	283	73	3	610
★ SHP335.120P.CD1	3500/500	1200	980	68	29	284	75	3	620
★ SHP335.125P.CD1	3500/500	1250	980	68	29	285	77	3	660
★ SHP335.130P.CD1	3500/500	1300	980	68	29	285	86	3	680
★ SHP335.135P.CD1	3500/500	1350	1080	68	29	286	89	3	690
★ SHP335.140P.CD1	3500/500	1400	1080	68	29	287	90	3	700

★ Suggested selection

Advantages

- Reinforced frame corners
- Extremely strong, one-piece top bar
- Cylinder connected by a single spring pin
- User-friendly design
- Expertly manufactured
- Superior mechanical strength

Available on request

- Load backrest (see page 20)

TRF

1000 kg
2500 kg

Sideshifters ISO/FEM 1-2 with sliding pads

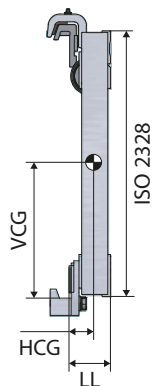
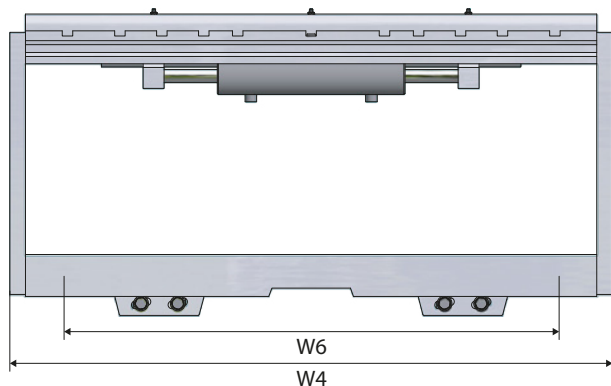

Product info

- W6 – Minimum carriage width
- Total sideshifter stroke: 100 + 100 mm



Model	Capacity	W4	W6	LL	HCG	VCG	Weight	ISO 2328	RRP
	kg/mm	mm	mm	mm	mm	mm	kg		Euro
TRF112.080P	1000/500	800	700	70	34	183	45	1	570
TRF112.085P	1000/500	850	700	70	34	183	47	1	580
TRF112.100P	1000/500	1000	850	70	34	183	53	1	580
★ TRF225.080P	2500/600	800	700	70	34	225	47	2	580
TRF225.090P	2500/600	900	800	70	34	225	50	2	580
TRF225.092P	2500/600	920	800	70	34	225	50	2	580
TRF225.094P	2500/600	940	800	70	34	225	52	2	580
TRF225.097P	2500/600	970	840	70	34	226	53	2	580
★ TRF225.098P	2500/600	980	850	70	34	226	54	2	580
★ TRF225.100P	2500/600	1000	850	70	34	226	54	2	590
★ TRF225.102P	2500/600	1020	850	70	34	226	55	2	590
★ TRF225.104P	2500/600	1040	850	70	34	226	56	2	590
TRF225.107P	2500/600	1070	870	70	34	226	57	2	590
★ TRF225.110P	2500/600	1100	900	70	34	226	58	2	640
★ TRF225.115P	2500/600	1150	900	70	34	226	60	2	640
★ TRF225.126P	2500/600	1260	1000	70	34	228	68	2	820
★ TRF225.140P	2500/600	1400	1100	70	34	228	72	2	890

★ Suggested selection

Options

	RRP
	Euro
Class 2 bronze lower pads	On request
Class 2 bronze upper and lower pads	On request

Available on request

- Sideshifter for reach trucks
- Custom-made sideshifters
- Load backrest (see page 20)

Advantages

- High-mounted cylinder for superior visibility
- Extremely strong and robust, single-piece upper S bar
- Fully protected pads
- Grease fittings on top of the upper bar
- Ideal for intensive use
- Expertly manufactured
- Superior mechanical strength

Sideshifters ISO/FEM 3 with sliding pads

TRF

3500 kg
5000 kg

Product info

- W6 – Minimum carriage width
- Total sideshifter stroke: 100 + 100 mm (FEM 3)
- Total sideshifter stroke: 150 + 150 mm (FEM 4)

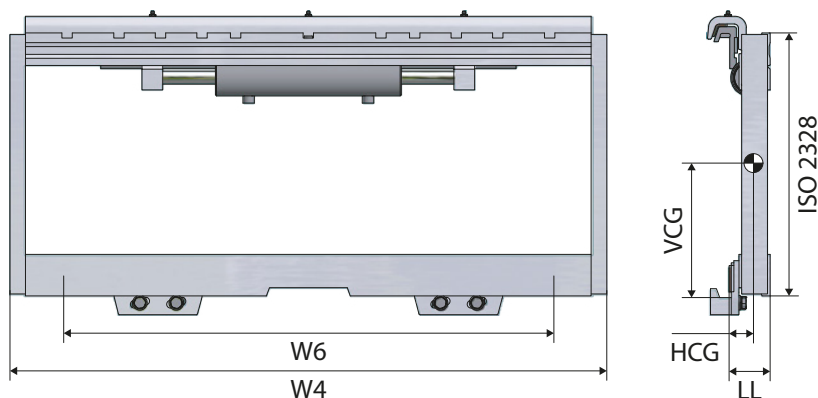

Model	Capacity	W4	W6	LL	HCG	VCG	Weight	ISO 2328	RRP
	kg/mm	mm	mm	mm	mm	mm			kg
★ TRF335.100P	3500/500	1000	900	80	35	305	79	3	780
★ TRF335.107P	3500/500	1070	950	80	35	308	83	3	850
★ TRF335.110P	3500/500	1100	1000	80	35	308	85	3	860
★ TRF335.115P	3500/500	1150	1000	80	35	309	88	3	880
★ TRF335.120P	3500/500	1200	1000	80	35	309	90	3	920
TRF335.125P	3500/500	1250	1100	80	35	314	95	3	930
TRF335.130P	3500/500	1300	1100	80	36	314	98	3	950
★ TRF335.135P	3500/500	1350	1100	80	36	314	100	3	970
TRF350.100P	5000/500	1000	900	80	36	277	98	3	1000
TRF350.107P	5000/500	1070	950	80	36	279	102	3	1000
★ TRF350.110P	5000/500	1100	950	80	36	279	104	3	1000
★ TRF350.115P	5000/500	1150	950	80	36	279	107	3	1090
★ TRF350.120P	5000/500	1200	1000	80	36	279	110	3	1110
★ TRF350.126P	5000/500	1260	1000	80	36	280	115	3	1170
★ TRF350.130P	5000/500	1300	1000	80	36	280	118	3	1180
★ TRF350.135P	5000/500	1350	1050	80	36	280	120	3	1190
★ TRF350.156P	5000/500	1560	1250	80	37	280	151	3	1360
★ TRF350.166P	5000/500	1660	1350	80	37	280	155	3	1410
★ TRF350.175P	5000/500	1750	1450	80	37	280	160	3	1480
★ TRF350.185P	5000/500	1850	1500	80	38	280	168	3	1560
★ TRF350.200P	5000/500	2000	1600	80	38	280	178	3	1720

★ Suggested selection

TRF

5000 kg
6500 kg

Sideshifters ISO/FEM 3-4 with sliding pads

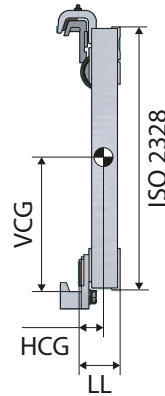
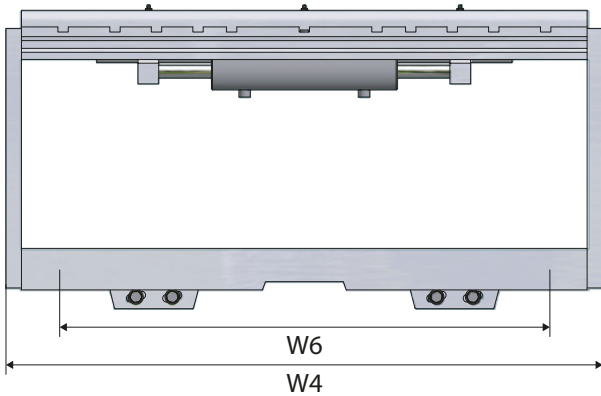

Product info

- W6 – Minimum carriage width
- Total sideshifter stroke: 100 + 100 mm (FEM 3)
- Total sideshifter stroke: 150 + 150 mm (FEM 4)



Model	Capacity	W4	W6	LL	HCG	VCG	Weight	ISO 2328	RRP
	kg/mm								mm
TRF360.100P	5000/600	1000	900	80	39	249	128	3	1420
TRF360.107P	5000/600	1070	950	80	39	251	132	3	1420
TRF360.110P	5000/600	1100	950	80	39	251	134	3	1420
TRF360.115P	5000/600	1150	950	80	39	251	137	3	1570
TRF360.120P	5000/600	1200	1000	80	39	251	140	3	1610
TRF360.126P	5000/600	1260	1000	80	39	252	145	3	1650
TRF360.130P	5000/600	1300	1000	80	40	252	148	3	1650
TRF360.135P	5000/600	1350	1050	80	40	252	150	3	1690
TRF360.156P	5000/600	1560	1250	80	40	252	181	3	1750
TRF360.166P	5000/600	1660	1350	80	40	252	185	3	1800
TRF360.175P	5000/600	1750	1450	80	41	252	190	3	1850
TRF360.185P	5000/600	1850	1500	80	41	252	198	3	1900
TRF360.200P	5000/600	2000	1600	80	41	252	208	3	2240
TRF450.120P	5000/600	1200	1050	100	48	352	205	4	2280
TRF450.135P	5000/600	1350	1150	100	48	354	224	4	2390
TRF450.160P	5000/600	1600	1300	100	48	357	253	4	2540
TRF450.180P	5000/600	1800	1500	100	48	362	280	4	2700
★ TRF465.120P	6500/600	1200	1050	100	48	357	210	4	2430
★ TRF465.135P	6500/600	1350	1150	100	48	359	229	4	2550
★ TRF465.160P	6500/600	1600	1300	100	48	362	258	4	2670
★ TRF465.180P	6500/600	1800	1500	100	48	367	285	4	2810

★ Suggested selection

Sideshifters ISO/FEM 4 with sliding pads

TRF

8000 kg
12000 kg

Product info

- W6 – Minimum carriage width
- Total sideshifter stroke: 150 + 150 mm (FEM 4)

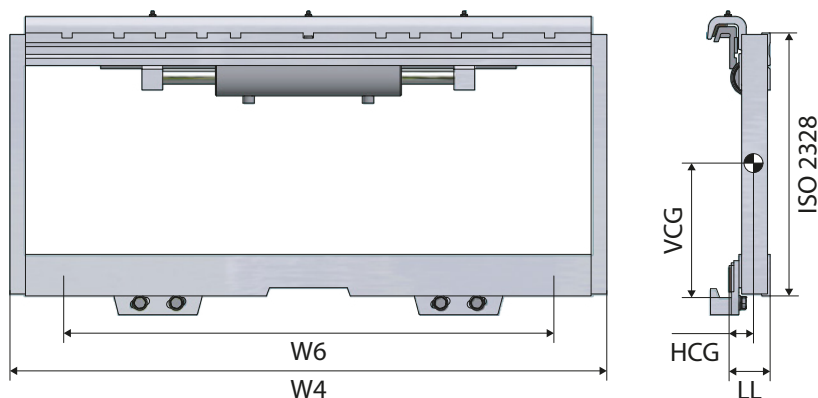

Model	Capacity	W4	W6	LL	HCG	VCG	Weight	ISO 2328	RRP
	kg/mm	mm	mm	mm	mm	mm	kg		Euro
★ TRF480.180P	8000/600	1800	1500	100	50	346	310	4	2879
★ TRF480.200P	8000/600	2000	1650	100	50	348	341	4	2940
★ TRF480.220P	8000/600	2200	1800	100	50	350	368	4	3210
★ TRF480.240P	8000/600	2400	1950	100	50	350	397	4	3510
TRF4120.220P	12000/600	2200	1850	115	55	350	520	4	6050
TRF4120.240P	12000/600	2400	1950	115	56	352	555	4	6450

★ Suggested selection

Options

	RRP
	Euro
Class 3 or class 4 bronze lower pads	On request
Class 3 or class 4 bronze upper and lower pads	On request

Available on request

- Load backrest (see page 20)
- Sideshifter FEM 3 and FEM 4 with rollers

Advantages

- High-mounted cylinder for superior visibility
- Extremely strong and robust, single-piece upper S-bar
- Fully protected pads
- Grease fittings on top of the upper bar
- Ideal for intensive use
- Expertly manufactured
- Superior mechanical strength

2DL-3DL

1000 kg
2000 kg

Dual and triple sidershifters

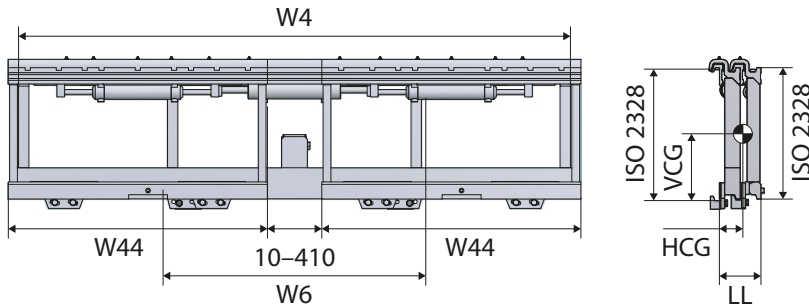

Product info

- W6 – Minimum carriage width
- Prices exclude forks
- Technical data without forks
- Flow divider



Model	Capacity kg/mm	W4 mm	W44 mm	W6 mm	LL mm	HCG mm	VCG mm	Weight kg	Stroke mm	ISO 2328 Truck carriage	ISO 2328 Sidershifter carriage	RRP
												Euro
Dual sidershifter												
2DL2220.170	2 x 1000/500	1700	750	1100	124	61	226	173	2 x 200	2	2	5000
2DL2220.200	2 x 1000/500	2000	900	1150	124	61	226	198	2 x 200	2	2	5250
2DL2220.215	2 x 1000/500	2150	1000	1200	124	61	226	219	2 x 200	2	2	5510
2DL3240.170	2 x 2000/500	1700	750	1100	134	57	227	250	2 x 200	3	2	6110
2DL3240.200	2 x 2000/500	2000	900	1150	134	58	227	284	2 x 200	3	2	6360
2DL3240.215	2 x 2000/500	2150	1000	1200	134	58	227	304	2 x 200	3	2	6590
Triple sidershifter												
3DL2220.170	2 x 1000/500	1700	750	1300	139	65	236	183	3 x 200	2	2	6690
3DL2220.200	2 x 1000/500	2000	900	1350	139	65	236	208	3 x 200	2	2	6960
3DL2220.215	2 x 1000/500	2150	1000	1400	139	65	236	229	3 x 200	2	2	7210
3DL3240.170	2 x 2000/500	1700	750	1300	161	67	283	272	3 x 200	3	2	7820
3DL3240.200	2 x 2000/500	2000	900	1350	161	67	283	316	3 x 200	3	2	8080
3DL3240.215	2 x 2000/500	2150	1000	1400	161	67	283	346	3 x 200	3	2	8320

2DL: fixed rear frame (no sidershift)

3DL: main sidershifter on the rear frame

Available on request

- Independent movement of the front sidershifters

Standard hose kit for separate sideshifter

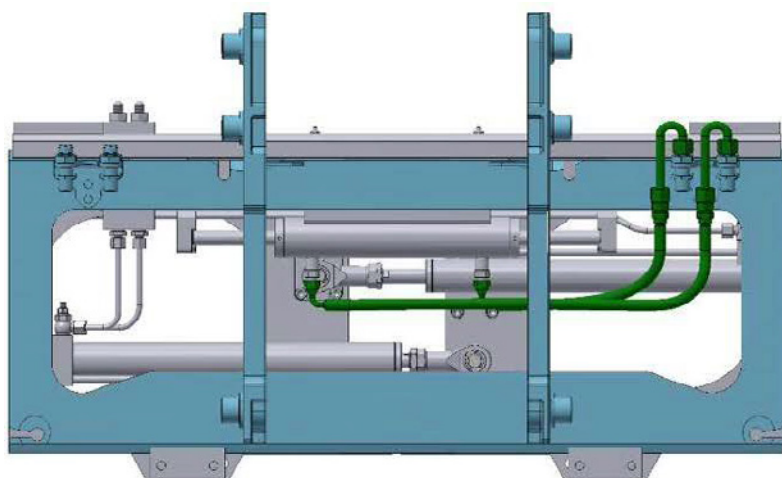

Code	Description	Gross price*
KIT.H.TS2	For separate sideshift FEM2	€370 ea
KIT.H.TS3	For separate sideshift FEM3	€370 ea
KIT.H.TS4	For separate sideshift FEM4	€370 ea

KIT INCLUDE 2X HOSES AND FITTINGS
CONNECTION TO LIFT TRUCK M2OX1,5 (12S)

*Prices apply when ordered together with an attachment

Connection Hose Configurator

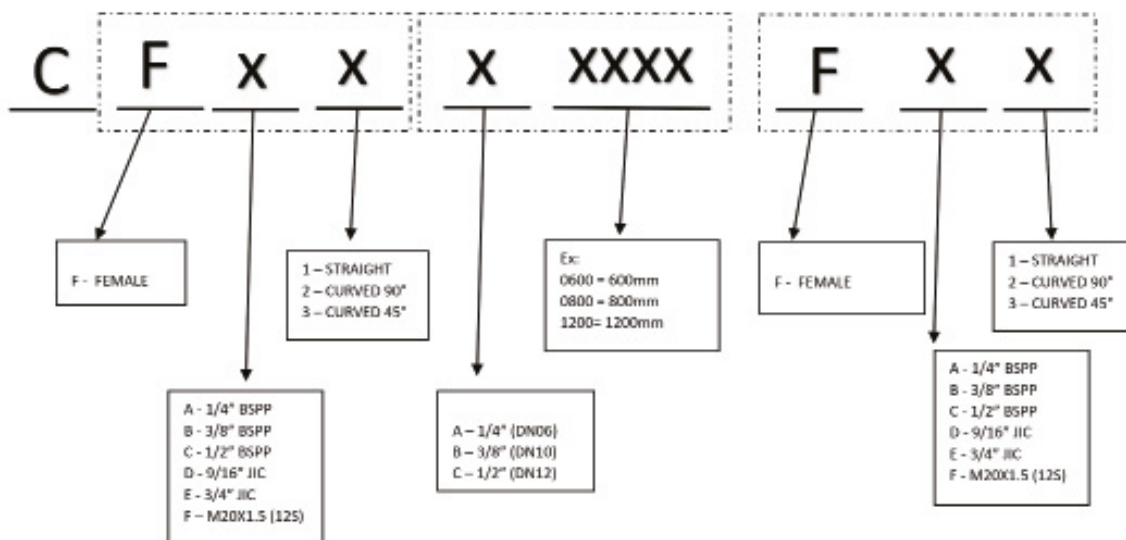

GROSS PRICE*: €135 ea

Accessories

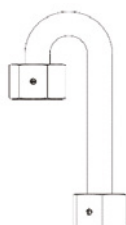

SPECIAL 180° FITTING
M20X1.5 BOTH TERMINALS

[C035414](#)

GROSS PRICE*: € 50 ea



Quick Release Coupling

Model	A	B	GROSS PRICE*
C035023.F	1/2" FEMALE	1/2" FEMALE	€60 ea
C035024.F	1/2" FEMALE	M20x1.5 (12S) MALE	€60 ea
C035025.F	3/8" FEMALE	3/8" FEMALE	€60 ea

*Prices apply when ordered together with an attachment

LBR**2500 kg
5000 kg**

Load backrest for sidershifters

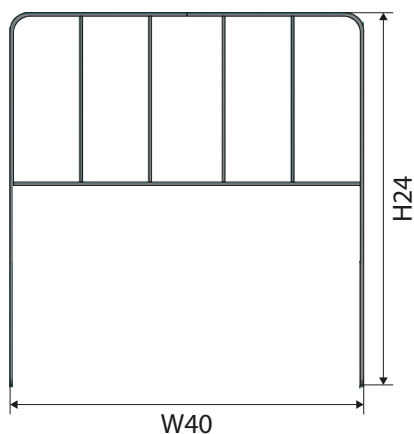
**Product info**

- Hardware kit included



Model	Usable for sidershifters		W40	H24	Weight	RRP
			mm	mm	kg	Euro
CC36334	SHP225.080P.CD1	SHP225.080P.LB2	825	1120	25	325
CC36336	SHP225.090P.CD1	SHP225.090P.LB2	925	1120	26	325
CC36338	SHP225.092P.CD1	SHP225.092P.LB2	945	1120	26	325
CC36340	SHP225.094P.CD1	SHP225.094.LB2	965	1120	26	325
CC36342	SHP225.098P.CD1	SHP225.098P.LB2	1005	1120	26	325
CC36344	SHP225.100P.CD1	SHP225.100P.LB2	1025	1120	26	325
CC36346	SHP225.102P.CD1	SHP225.102P.LB2	1045	1120	27	325
CC36348	SHP225.104P.CD1	SHP225.104P.LB2	1065	1120	28	325
CC36350	SHP225.107P.CD1	SHP225.107P.LB2	1095	1120	28	325
CC36352	SHP225.110P.CD1	SHP225.110P.LB2	1125	1120	28	325
CC36354	SHP225.115P.CD1	SHP225.115P.LB2	1175	1120	29	325
CC36356	SHP225.125P.CD1	SHP225.125P.LB2	1275	1120	30	325
CC36358	SHP225.140P.CD1	SHP225.140P.LB2	1425	1120	31	325
CC36360	SHP335.100P.CD1	SHP335.100P.LB4	1025	1105	32	430
CC36362	SHP335.102P.CD1	SHP335.102P.LB4	1045	1105	33	430
CC36364	SHP335.107P.CD1	SHP335.107P.LB4	1095	1105	34	430
CC36366	SHP335.110P.CD1	SHP335.110P.LB4	1125	1105	35	430
CC36368	SHP335.115P.CD1	SHP335.115P.LB4	1175	1105	35	430
CC36370	SHP335.120P.CD1	SHP335.120P.LB4	1225	1105	36	430
CC36372	SHP335.125P.CD1	SHP335.125P.LB4	1275	1105	37	430
CC36374	SHP335.130P.CD1	SHP335.130P.LB4	1325	1105	37	430
CC36376	SHP335.135P.CD1	SHP335.135P.LB4	1375	1105	38	430
CC36378	SHP335.140P.CD1	SHP335.140P.LB4	1425	1105	40	430

Options

	RRP
	Euro
High strength threadlocker 50 ml: BA57042	On request

Technical data

Sideshifters

Model	Sideshifting						Hydraulic functions
	Operating pressure			Oil flow rate			
	Min.	Recommended	Max.	Min.	Recommended	Max.	
SHP225	130	160	220	4	10	15	1
SHP335	130	160	220	6	12	18	1
TRF 112	130	160	220	4	10	15	1
TRF 225	130	160	220	4	10	15	1
TRF 335	130	160	220	6	12	18	1
TRF 350	130	160	220	6	12	20	1
TRF 465	130	160	220	7	14	20	1
TRF 480	130	160	220	7	14	25	1
TRF4120	130	160	220	7	14	25	1
2DL	130	160	220	6	12	20	1
3DL	130	160	220	6	12	20	2



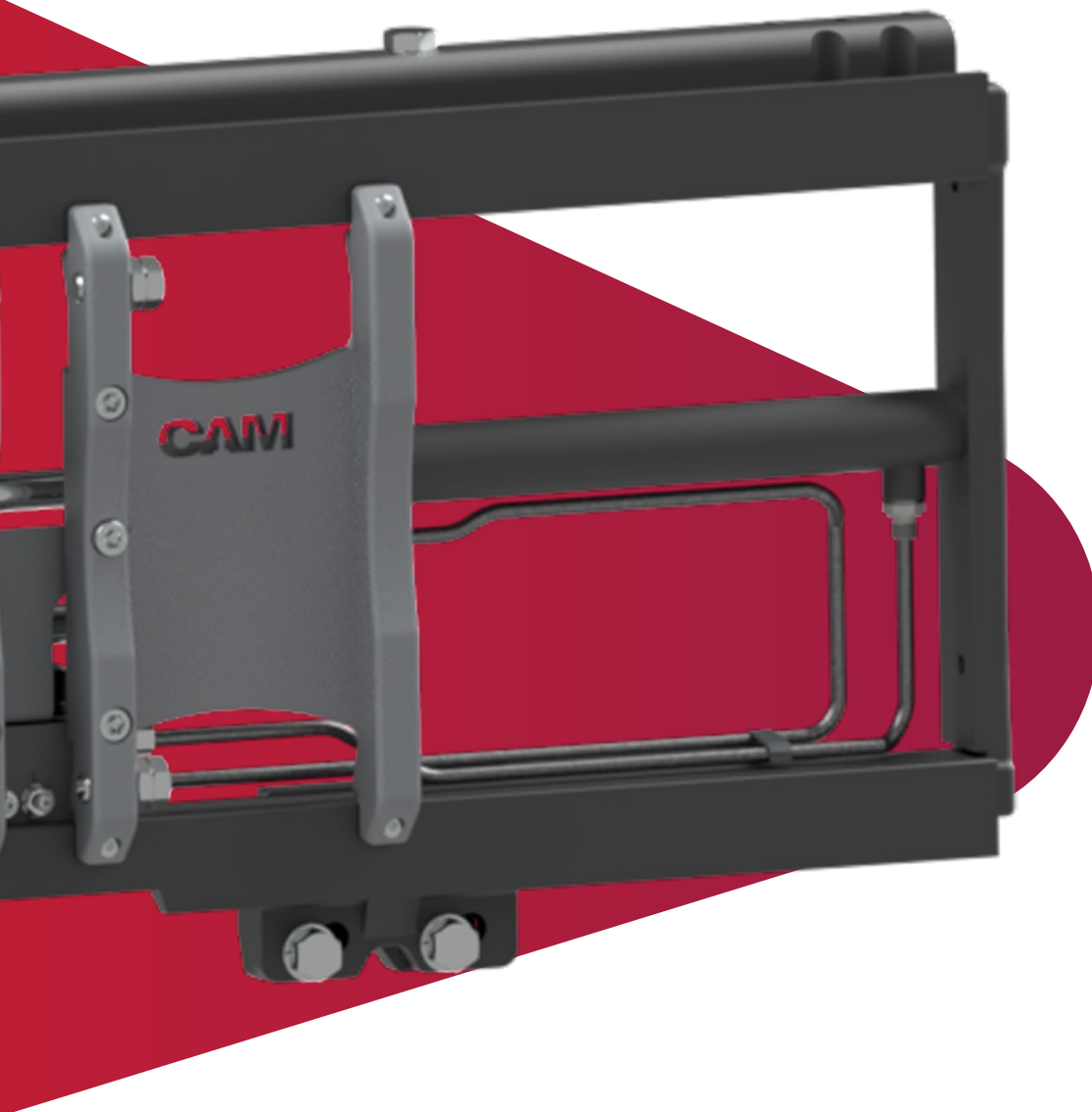

2. Fork positioners

Do you often have to handle pallets of different sizes? Fork positioners are the answer! They allow you to hydraulically move the forks closer together or further apart, individually or together. Say goodbye to manual adjustments and serious damage to pallets and products.

PH

2500 kg
5000 kg

Fork positioner with FEM fork carriers without sideshifter

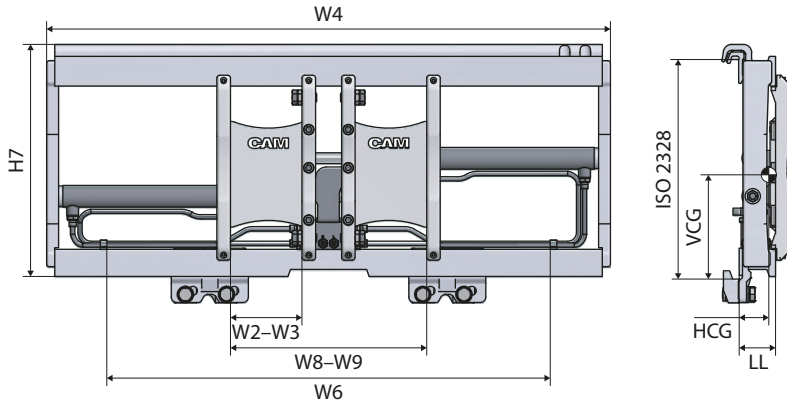

Product info

- W6 – Minimum carriage width
- Technical data without forks
- Maximum advised fork length FEM 2–FEM 3: 1800 mm
- Without separate sideshifter
- Standard forks can be easily fitted
- Valve block with flow divider
- Galvanized pockets
- Galvanized steel oil circuit hoses



Model	Capacity	W8-W9 mm	W4 mm	W6 mm	W2-W3 mm	H7 mm	LL mm	HCG mm	VCG mm	Weight kg	ISO 2328	RRP
	kg/mm											Euro
★ PH25.092	2500/600	360–850	920	800	80–130	435	67	36	197	66	2	1914
★ PH25.098	2500/600	360–910	980	800	80–130	435	67	36	201	68	2	1918
★ PH25.102	2500/600	360–950	1020	800	80–130	435	67	36	201	70	2	1989
★ PH25.104	2500/600	360–970	1040	800	80–130	435	67	36	201	71	2	1998
★ PH25.110	2500/600	360–1030	1100	800	80–130	435	67	37	202	73	2	2009
★ PH25.115	2500/600	360–1080	1150	800	80–130	435	67	37	202	75	2	2022
PH35.105	3500/500	360–980	1050	900	100–130	539	77	40	267	104	3	2488
★ PH35.110	3500/500	360–1030	1100	900	100–130	539	77	40	268	107	3	2518
★ PH35.115	3500/500	360–1080	1150	900	100–130	539	77	40	269	110	3	2636
★ PH35.125	3500/500	360–1180	1250	900	100–130	539	77	40	270	116	3	2936
★ PH50.115	5000/500	410–1020	1150	900	120–150	539	79	44	255	128	3	3139
★ PH50.125	5000/500	410–1120	1250	1000	120–150	539	79	44	255	136	3	3054
★ PH50.135	5000/500	410–1220	1350	1100	120–150	539	79	44	255	143	3	3133
PH50.170	5000/500	410–1570	1700	1250	120–150	539	79	44	255	170	3	3969

★ Suggested selection

Attachment not recommended for clamping between forks

Advantages

- Easy to install
- Improved safety thanks to better visibility through the frame
- Galvanised fork pockets and oil circuit hoses
- Expertly manufactured
- Superior mechanical strength
- Forks positioning with flow divider

Available on request

- Load backrest

Fork positioner with FEM fork carriers without sideshifter

PH

5500 kg
12000 kg

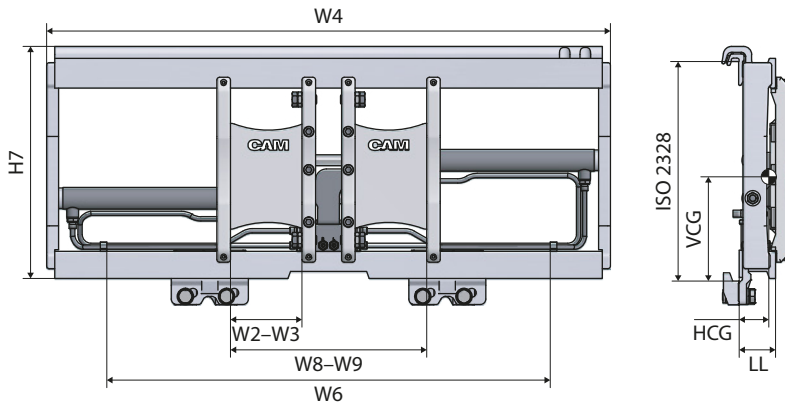

Product info

- W6 – Minimum carriage width
- Technical data without forks
- Maximum advised fork length FEM 4: 2400 mm
- Without separate sideshifter
- Standard forks can be easily fitted
- Valve block with flow divider
- Galvanized pockets
- Galvanized steel oil circuit hoses



Model	Capacity	W8-W9 mm	W4 mm	W6 mm	W2-W3 mm	H7 mm	LL mm	HCG mm	VCG mm	Weight kg	ISO 2328	RRP
	kg/mm											Euro
PH55.120	5500/600	460-1050	1200	900	120-150	674	100	55	346	228	4	3973
PH55.135	5500/600	460-1200	1350	1050	120-150	674	100	55	346	252	4	4077
PH55.150	5500/600	460-1350	1500	1150	120-150	674	100	55	352	264	4	4176
PH55.170	5500/600	460-1550	1700	1250	120-150	674	100	55	355	288	4	4884
PH70.120	7000/600	460-1010	1200	1000	120-150	674	100	54	346	255	4	4097
PH70.135	7000/600	460-1160	1350	1000	120-150	674	100	54	346	285	4	4321
PH70.150	7000/600	460-1310	1500	1100	120-150	674	100	54	347	301	4	4517
PH70.180	7000/600	460-1610	1800	1100	120-150	674	100	54	347	342	4	4744
PH70.200	7000/600	460-1810	2000	1500	120-150	674	100	54	348	369	4	5473
PH70.220	7000/600	460-2010	2200	1700	120-150	674	100	54	348	397	4	5957
PH80.120	8000/600	460-1010	1200	1000	150-200	674	100	54	330	265	4	4360
PH80.150	8000/600	460-1310	1500	1150	150-200	674	100	54	332	311	4	4774
PH80.180	8000/600	460-1610	1800	1300	150-200	674	100	54	334	352	4	5252
PH80.200	8000/600	460-1810	2000	1500	150-200	674	100	54	335	379	4	5736
PH80.220	8000/600	460-2010	2200	1700	150-200	674	100	54	338	398	4	6210
PH80.240	8000/600	460-2210	2400	1900	150-200	674	100	54	340	417	4	6422
PH120.180	12000/600	540-1580	1800	1400	150-200	697	130	67	357	425	4	8932
PH120.200	12000/600	540-1780	2000	1600	150-200	697	130	67	352	470	4	9343
PH120.220	12000/600	540-1980	2200	1800	150-200	697	130	67	347	505	4	9851

Attachment not recommended for clamping between forks

Advantages

- Easy to install
- Improved safety thanks to better visibility through the frame
- Galvanized fork pockets and oil circuit hoses
- Expertly manufactured
- Superior mechanical strength
- Forks positioning with flow divider

Available on request

- Load backrest

PH-T

2500 kg
5000 kg

Fork positioner with FEM fork carriers with sideshifter

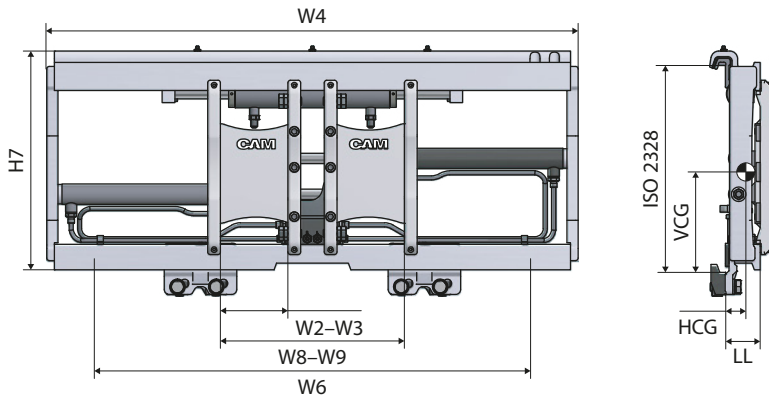

Product info

- W6 – Minimum carriage width
- Technical data without forks
- Maximum advised fork length FEM 2–FEM 3: 1800 mm
- With separate sideshifter
- Standard forks can be easily fitted
- Total sideshifter stroke: 100 + 100 mm (FEM 2–FEM 3)
- Valve block with flow divider
- Galvanized pockets
- Galvanized steel oil circuit hoses
- Upper and lower bushings with grease nipples



Model	Capacity	W8–W9 mm	W4 mm	W6 mm	W2–W3 mm	H7 mm	LL mm	HCG mm	VCG mm	Weight kg	ISO 2328	RRP
	kg/mm											Euro
★ PH25T.092	2500/600	360–850	920	800	80–130	435	68	36	213	71	2	1980
★ PH25T.098	2500/600	360–910	980	800	80–130	435	68	36	215	75	2	1984
★ PH25T.102	2500/600	360–950	1020	800	80–130	435	68	36	215	76	2	2055
★ PH25T.104	2500/600	360–970	1040	800	80–130	435	68	36	215	78	2	2064
★ PH25T.110	2500/600	360–1030	1100	800	80–130	435	68	36	215	81	2	2075
★ PH25T.115	2500/600	360–1080	1150	800	80–130	435	68	36	215	83	2	2088
PH35T.105	3500/500	360–980	1050	900	100–130	539	78	40	287	112	3	2554
★ PH35T.110	3500/500	360–1030	1100	900	100–130	539	78	40	287	115	3	2584
★ PH35T.115	3500/500	360–1080	1150	900	100–130	539	78	40	287	120	3	2702
★ PH35T.125	3500/500	360–1180	1250	1000	100–130	539	78	40	287	125	3	3002
★ PH50T.115	5000/500	410–1020	1150	900	120–150	539	78	41	273	142	3	3227
★ PH50T.125	5000/500	410–1120	1250	1000	120–150	539	78	41	273	150	3	3142
★ PH50T.135	5000/500	410–1220	1350	1100	120–150	539	78	41	274	160	3	3221
PH50T.170	5000/500	410–1570	1700	1300	120–150	539	78	41	276	190	3	4057

★ Suggested selection

Attachment not recommended for clamping between forks

Advantages

- Easy to install
- Improved safety thanks to better visibility through the frame
- Galvanized fork pockets and oil circuit hoses
- Expertly manufactured
- Superior mechanical strength
- Forks positioning with flow divider

Available on request

- Load backrest (see page 20)
- Upper and lower bronze bushings

Fork positioner with FEM fork carriers with sideshifter

PH-T

5500 kg
12000 kg

Product info

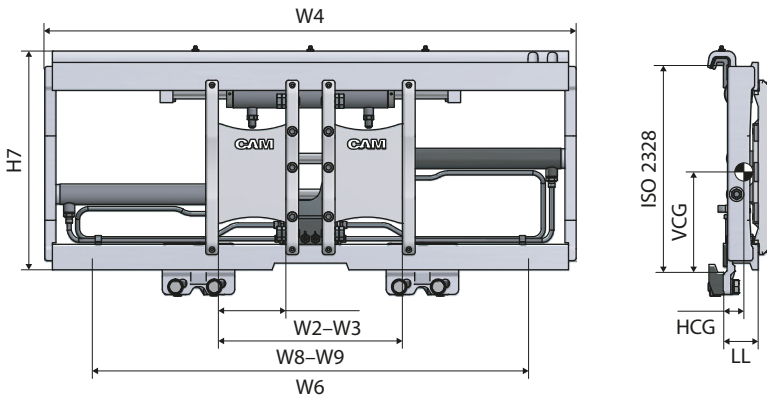

- W6 – Minimum carriage width
- Technical data without forks
- Maximum advised fork length FEM 4: 2400 mm
- With separate sideshifter
- Standard forks can be easily fitted
- Total sideshifter stroke: 150 + 150 mm (FEM 4)
- Valve block with flow divider
- Galvanized pockets
- Galvanized steel oil circuit hoses



Model	Capacity	W8-W9	W4	W6	W2-W3	H7	LL	HCG	VCG	Weight	ISO 2328	RRP
	kg/mm											mm
★ PH55T.120	5500/600	460-1050	1200	1050	120-150	674	100	53	362	247	4	4061
★ PH55T.135	5500/600	460-1200	1350	1100	120-150	674	100	53	362	273	4	4165
★ PH55T.150	5500/600	460-1350	1500	1150	120-150	674	100	53	366	284	4	4264
★ PH55T.170	5500/600	460-1550	1700	1350	120-150	674	100	53	370	311	4	4972
PH70T.120	7000/600	460-1010	1200	1150	120-150	674	100	53	346	278	4	4185
PH70T.135	7000/600	460-1160	1350	1150	120-150	674	100	53	348	300	4	4409
★ PH70T.150	7000/600	460-1310	1500	1300	120-150	674	100	53	348	320	4	4605
★ PH70T.180	7000/600	460-1610	1800	1300	120-150	674	100	53	353	372	4	4832
★ PH70T.200	7000/600	460-1810	2000	1500	120-150	674	100	53	353	395	4	5561
PH70T.220	7000/600	460-2010	2200	1700	120-150	674	100	53	353	425	4	6045
PH80T.120	8000/600	460-1010	1200	1150	150-200	674	100	56	343	288	4	4448
PH80T.150	8000/600	460-1310	1500	1300	150-200	674	100	56	346	322	4	4862
★ PH80T.180	8000/600	460-1610	1800	1300	150-200	674	100	56	351	366	4	5340
★ PH80T.200	8000/600	460-1810	2000	1500	150-200	674	100	56	353	395	4	5824
★ PH80T.220	8000/600	460-2010	2200	1700	150-200	674	100	56	353	435	4	6298
PH80T.240	8000/600	460-2210	2400	1900	150-200	674	100	56	355	456	4	6822
PH120T.180	12000/600	540-1580	1800	1400	150-200	697	130	67	355	465	4	9020
PH120T.200	12000/600	540-1780	2000	1600	150-200	697	130	67	352	511	4	9431
PH120T.220	12000/600	540-1980	2200	1800	150-200	697	130	67	347	545	4	9939

★ Suggested selection

Attachment not recommended for clamping between forks

Advantages

- Easy to install
- Improved safety thanks to better visibility through the frame
- Galvanized fork pockets and oil circuit hoses
- Expertly manufactured
- Superior mechanical strength
- Forks positioning with flow divider

Available on request

- Load backrest (see page 20)
- Upper and lower bronze bushings

PH.SIN

2500 kg
5500 kg

Fork positioner with FEM fork carriers without sideshifter

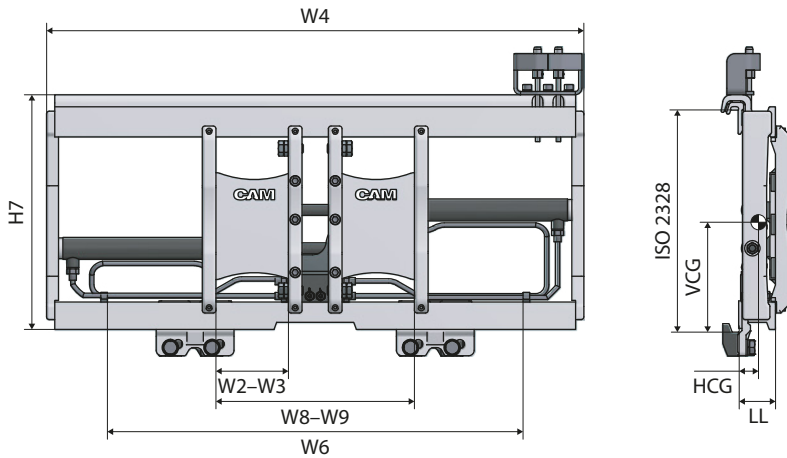

Product info

- W6 – Minimum carriage width
- Technical data without forks
- Maximum advised fork length: 1800 mm
- Without separate sideshifter
- Standard forklift forks can be easily fitted
- Valve block with flow divider
- Galvanized pockets
- Galvanized steel oil circuit hoses
- High termination connection



Model	Capacity	W8-W9 mm	W4 mm	W6 mm	W2-W3 mm	H7 mm	LL mm	HCG mm	VCG mm	Weight kg	ISO 2328	RRP
	kg/mm											Euro
★ PH25.092.SIN	2500/600	360-850	920	800	80-130	435	67	36	196	66	2	2092
★ PH25.098.SIN	2500/600	360-910	980	800	80-130	435	67	36	203	68	2	2097
★ PH25.102.SIN	2500/600	360-950	1020	800	80-130	435	67	36	204	70	2	2167
★ PH25.104.SIN	2500/600	360-970	1040	800	80-130	435	67	36	204	71	2	2176
★ PH25.110.SIN	2500/600	360-1030	1100	800	80-130	435	67	36	204	74	2	2187
★ PH25.115.SIN	2500/600	360-1080	1150	800	80-130	435	67	36	204	75	2	2200
PH35.105.SIN	3500/500	360-980	1050	900	100-130	539	77	40	270	105	3	2488
★ PH35.110.SIN	3500/500	360-1030	1100	900	100-130	539	77	40	271	108	3	2697
★ PH35.115.SIN	3500/500	360-1080	1150	900	100-130	539	77	40	272	111	3	2814
★ PH35.125.SIN	3500/500	360-1180	1250	900	100-130	539	77	40	273	117	3	3114
PH50.115.SIN	5000/500	410-1020	1150	900	120-150	539	79	44	258	129	3	3318
PH50.125.SIN	5000/500	410-1120	1250	1000	120-150	539	79	44	258	137	3	3232
PH50.135.SIN	5000/500	410-1220	1350	1100	120-150	539	79	44	258	144	3	3311
PH50.170.SIN	5000/500	410-1570	1700	1250	120-150	539	79	44	256	171	3	4147
PH55.120.SIN	5500/600	460-1050	1200	900	120-150	674	100	55	349	229	4	4151
PH55.135.SIN	5500/600	460-1200	1350	1050	120-150	674	100	55	349	253	4	4255
PH55.150.SIN	5500/600	460-1350	1500	1150	120-150	674	100	55	355	265	4	4354
PH55.170.SIN	5500/600	460-1550	1700	1250	120-150	674	100	55	358	289	4	5063

★ Suggested selection

Attachment not recommended for clamping between forks

Advantages

- Easy installation with compact space behind the carriage
- Improved safety thanks to better visibility through the frame
- Galvanized fork pockets and oil circuit hoses
- Expertly manufactured
- Superior mechanical strength
- Forks positioning with flow divider

Available on request

- Load backrest (see page 20)

Fork positioner with FEM fork carriers with sideshifter

PH-T.SIN

2500 kg
5500 kg

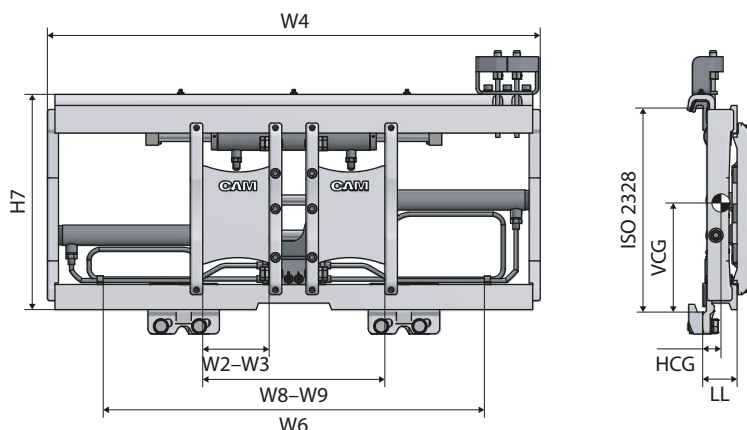

Product info

- W6 – Minimum carriage width
- Technical data without forks
- Maximum advised fork length: 1800 mm
- With separate sideshifter
- Standard forks can be easily fitted
- Total sideshifter stroke: 100 + 100 mm (FEM 2–FEM 3)
- Valve block with flow divider
- Galvanized pockets
- Galvanized steel oil circuit hoses
- High termination connection
- Upper and lower bushings with grease nipples



Model	Capacity	W8–W9 mm	W4 mm	W6 mm	W2–W3 mm	H7 mm	LL mm	HCG mm	VCG mm	Weight kg	ISO 2328	RRP
	kg/mm											Euro
★ PH25T.092.SIN	2500/600	360–850	920	800	80–130	435	68	36	215	72	2	2158
★ PH25T.098.SIN	2500/600	360–910	980	800	80–130	435	68	36	217	75	2	2163
★ PH25T.102.SIN	2500/600	360–950	1020	800	80–130	435	68	36	217	76	2	2233
★ PH25T.104.SIN	2500/600	360–970	1040	800	80–130	435	68	36	217	78	2	2242
★ PH25T.110.SIN	2500/600	360–1030	1100	800	80–130	435	68	36	217	81	2	2253
★ PH25T.115.SIN	2500/600	360–1080	1150	800	80–130	435	68	36	217	83	2	2266
PH35T.105.SIN	3500/500	360–980	1050	900	100–130	539	78	40	289	113	3	2554
★ PH35T.110.SIN	3500/500	360–1030	1100	900	100–130	539	78	40	289	116	3	2763
★ PH35T.115.SIN	3500/500	360–1080	1150	900	100–130	539	78	40	289	121	3	2880
★ PH35T.125.SIN	3500/500	360–1180	1250	1000	100–130	539	78	40	289	126	3	3180
PH50T.115.SIN	5000/500	410–1020	1150	1000	120–150	539	78	41	273	142	3	3406
PH50T.125.SIN	5000/500	410–1120	1250	1000	120–150	539	78	41	273	150	3	3320
PH50T.135.SIN	5000/500	410–1220	1350	1100	120–150	539	78	41	275	160	3	3399
PH50T.170.SIN	5000/500	410–1570	1700	1300	120–150	539	78	41	276	190	3	4235
PH55T.120.SIN	5500/600	460–1050	1200	1050	120–150	674	100	53	362	247	4	4239
PH55T.135.SIN	5500/600	460–1200	1350	1100	120–150	674	100	53	362	273	4	4343
PH55T.150.SIN	5500/600	460–1350	1500	1150	120–150	674	100	53	366	284	4	4442
PH55T.170.SIN	5500/600	460–1550	1700	1350	120–150	674	100	55	370	311	4	5151

★ Suggested selection

Advantages

- Easy installation with compact space behind the carriage
- Improved safety thanks to better visibility through the frame
- Galvanized fork pockets and oil circuit hoses
- Expertly manufactured
- Superior mechanical strength
- Forks positioning with flow divider

Available on request

- Load backrest (see page 20)
- Upper and lower bronze bushing
- Model with automatic synchronism

PL

2500 kg
3500 kg

Fork positioner with bar-mounted FEM fork carriers without sideshifter

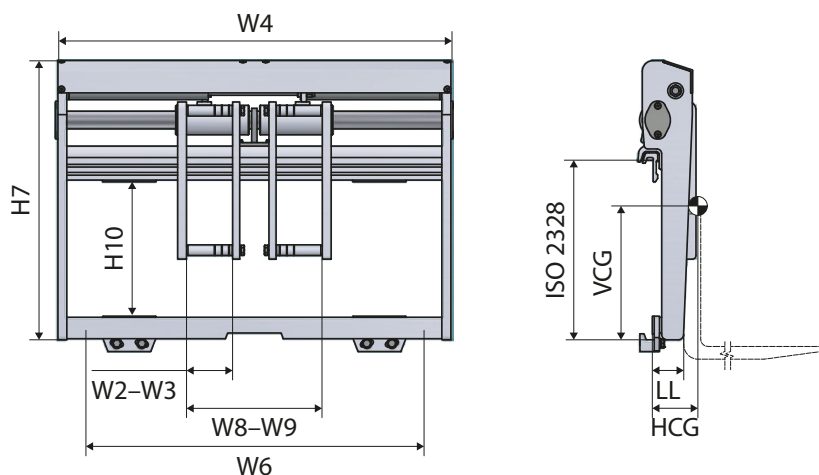

Product info

- W6 – Minimum carriage width
- Technical data without forks
- Maximum advised fork length: 1800 mm
- Self-lubricating upper sliding bushes
- With chrome round upper bar
- Without separate sideshifter
- Standard forks can be easily fitted
- Valve block with flow divider



Model	Capacity	W8-W9 mm	W4 mm	W6 mm	W2-W3 mm	H10 mm	H7 mm	LL mm	HCG mm	VCG mm	Weight kg	ISO 2328	RRP
	kg/mm												Euro
PL25.092	2500/600	340-790	920	800	80-130	300	670	70	38	368	106	2	2770
★ PL25.098	2500/600	340-850	980	800	80-130	300	670	70	38	368	109	2	2830
★ PL25.104	2500/600	340-910	1040	800	80-130	300	670	70	38	368	113	2	2900
PL25.110	2500/600	340-970	1100	800	80-130	300	670	70	38	368	116	2	3000
★ PL25.115	2500/600	340-1020	1150	800	80-130	300	670	70	38	368	121	2	3070
PL25.125	2500/600	340-1120	1250	800	80-130	300	670	70	38	368	124	2	3180
PL25.130	2500/600	340-1170	1300	800	80-130	300	670	70	38	368	131	2	3260
PL25.135	2500/600	340-1220	1350	800	80-130	300	670	70	38	368	133	2	3360
PL25.140	2500/600	340-1270	1400	900	80-130	300	670	70	38	368	135	2	3460
PL25.145	2500/600	340-1320	1450	900	80-130	300	670	70	38	368	136	2	3550
★ PL35.110	3500/500	380-960	1100	900	100-130	385	780	80	43	443	162	3	3480
★ PL35.115	3500/500	380-1010	1150	900	100-130	385	780	80	43	443	168	3	3650
★ PL35.125	3500/500	380-1110	1250	1000	100-130	385	780	80	43	443	177	3	3740
PL35.130	3500/500	380-1160	1300	1000	100-130	385	780	80	43	443	181	3	3840
PL35.135	3500/500	380-1210	1350	1000	100-130	385	780	80	43	443	184	3	3940
PL35.140	3500/500	380-1260	1400	1100	100-130	385	780	80	43	443	188	3	4130
PL35.145	3500/500	380-1310	1450	1100	100-130	385	780	80	43	443	193	3	4220
PL35.150	3500/500	380-1360	1500	1150	100-130	385	780	80	43	443	198	3	4320

★ Suggested selection

Attachment not recommended for clamping between forks

Advantages

- Easy to install
- Expertly manufactured
- Superior mechanical strength
- Forks positioning with flow divider
- Minimum LL thickness

Available on request

- Load backrest (see page 20)

Fork positioner with bar-mounted FEM fork carriers without sideshifter

PL
5000 kg

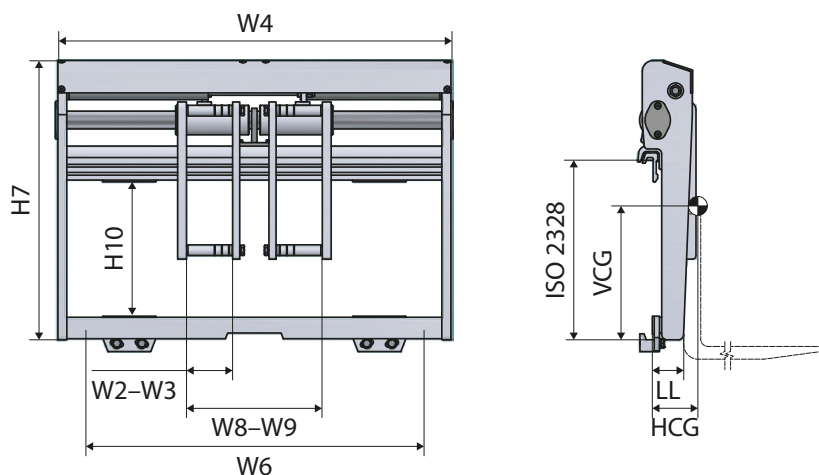

Product info

- W6 – Minimum carriage width
- Technical data without forks
- Maximum advised fork length: 1800 mm
- Self-lubricating upper sliding bushes
- With chrome round upper bar
- Without separate sideshifter
- Standard forks can be easily fitted
- Valve block with flow divider



Model	Capacity	W8-W9 mm	W4 mm	W6 mm	W2-W3 mm	H10 mm	H7 mm	LL mm	HCG mm	VCG mm	Weight kg	ISO 2328	RRP
	kg/mm												Euro
PL50.110	5000/500	380-960	1100	900	100-150	365	780	80	43	421	170	3	3630
PL50.115	5000/500	380-1010	1150	900	100-150	365	780	80	43	421	176	3	3750
PL50.125	5000/500	380-1110	1250	1000	100-150	365	780	80	43	419	188	3	3840
PL50.130	5000/500	380-1160	1300	1000	100-150	365	780	80	43	419	194	3	3920
PL50.135	5000/500	380-1210	1350	1000	100-150	365	780	80	43	419	197	3	4010
PL50.140	5000/500	380-1260	1400	1100	100-150	365	780	80	43	417	200	3	4130
PL50.145	5000/500	380-1310	1450	1100	100-150	365	780	80	43	417	205	3	4220
PL50.150	5000/500	380-1360	1500	1150	100-150	365	780	80	43	417	210	3	4320
PL50.155	5000/500	380-1410	1550	1250	100-150	365	780	80	43	417	215	3	4410
PL50.160	5000/500	380-1460	1600	1250	100-150	365	780	80	43	417	220	3	4530
PL50.165	5000/500	380-1510	1650	1300	100-150	365	780	80	43	417	225	3	4610

★ Suggested selection

Attachment not recommended for clamping between forks

Advantages

- Easy to install
- Expertly manufactured
- Superior mechanical strength
- Forks positioning with flow divider
- Minimum LL thickness

Available on request

- Load backrest (see page 20)

PL-T

2500 kg
3500 kg

Fork positioner with bar-mounted FEM fork carriers with separate sideshifter

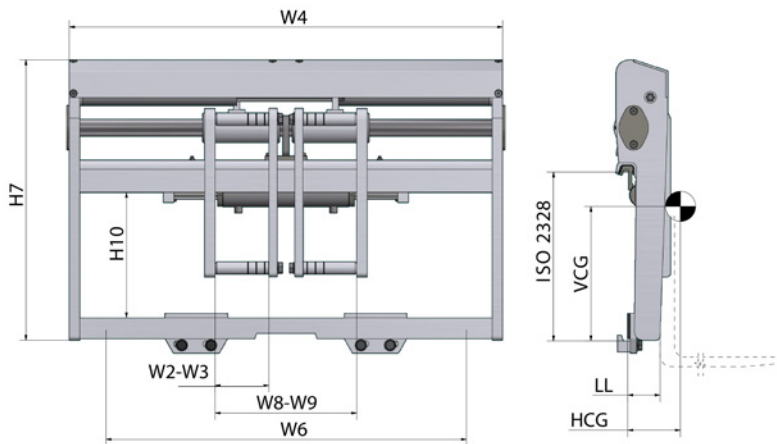

Product info

- W6 – Minimum carriage width
- Technical data without forks
- Maximum advised fork length: 1800 mm
- Self-lubricating upper sliding bushes
- With chrome round upper bar
- With separate sideshifter
- Standard forks can be easily fitted
- Total sideshifter stroke: 100 + 100 mm



Model	Capacity	W8-W9 mm	W4 mm	W6 mm	W2-W3 mm	H10 mm	H7 mm	LL mm	HCG mm	VCG mm	Weight kg	ISO 2328	RRP
	kg/mm												Euro
PL25T.092	2500/600	340-790	920	800	80/130	300	670	70	38	369	112	2	2900
★ PL25T.098	2500/600	340-850	980	800	80/130	300	670	70	38	369	115	2	2990
★ PL25T.104	2500/600	340-910	1040	800	80/130	300	670	70	38	369	120	2	3040
★ PL25T.110	2500/600	340-970	1100	900	80/130	300	670	70	38	369	122	2	3130
★ PL25T.115	2500/600	340-1020	1150	900	80/130	300	670	70	38	369	128	2	3230
★ PL25T.125	2500/600	340-1120	1250	950	80/130	300	670	70	38	369	132	2	3310
PL25T.130	2500/600	340-1170	1300	950	80/130	300	670	70	38	369	135	2	3400
PL25T.135	2500/600	340-1220	1350	950	80/130	300	670	70	38	369	137	2	3500
PL25T.140	2500/600	340-1270	1400	950	80/130	300	670	70	38	369	140	2	3600
PL25T.145	2500/600	340-1320	1450	1050	80/130	300	670	70	38	369	143	2	3700
PL35T.110	3500/500	380-960	1100	900	100/130	385	780	80	42	449	173	3	3810
PL35T.115	3500/500	380-1010	1150	900	100/130	385	780	80	42	447	177	3	3950
PL35T.125	3500/500	380-1110	1250	900	100/130	385	780	80	42	447	185	3	4100
PL35T.130	3500/500	380-1160	1300	900	100/130	385	780	80	42	447	190	3	4180
PL35T.135	3500/500	380-1210	1350	1000	100/130	385	780	80	42	447	195	3	4290
PL35T.140	3500/500	380-1260	1400	1100	100/130	385	780	80	42	447	198	3	4450
PL35T.145	3500/500	380-1310	1450	1100	100/130	385	780	80	42	447	202	3	4550
PL35T.150	3500/500	380-1360	1500	1150	100/130	385	780	80	42	447	208	3	4640

★ Suggested selection

Attachment not recommended for clamping between forks

Advantages

- Easy to install
- Expertly manufactured
- Superior mechanical strength
- Forks positioning with flow divider
- Minimum LL thickness

Available on request

- Load backrest
- Upper and lower bushing for hard work

Fork positioner with bar-mounted FEM fork carriers with separate sideshifter

PL-T
5000 kg

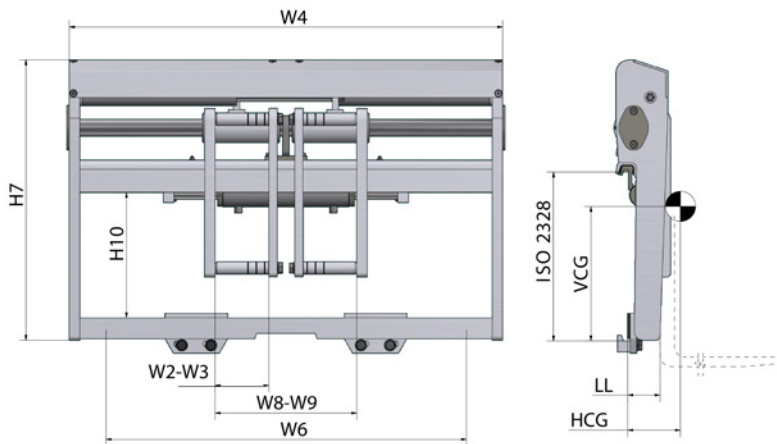

Product info

- W6 – Minimum carriage width
- Technical data without forks
- Maximum advised fork length: 1800 mm
- Self-lubricating upper sliding bushes
- With chrome round upper bar
- With separate sideshifter
- Standard forks can be easily fitted
- Total sideshifter stroke: 100 + 100 mm



Model	Capacity	W8-W9	W4	W6	W2-W3	H10	H7	LL	HCG	VCG	Weight	ISO 2328	RRP
	kg/mm	mm	mm	mm	mm	mm	mm	mm	mm	mm	kg		Euro
PL50T.110	5000/500	380-960	1100	900	100/150	365	780	80	42	418	185	3	3950
PL50T.115	5000/500	380-1010	1150	900	100/150	365	780	80	42	418	191	3	4100
PL50T.125	5000/500	380-1110	1250	1000	100/150	365	780	80	42	418	208	3	4150
PL50T.130	5000/500	380-1160	1300	1000	100/150	365	780	80	42	418	212	3	4240
PL50T.135	5000/500	380-1210	1350	1000	100/150	365	780	80	42	418	215	3	4350
PL50T.140	5000/500	380-1260	1400	1100	100/150	365	780	80	42	418	218	3	4450
PL50T.145	5000/500	380-1310	1450	1100	100/150	365	780	80	42	416	222	3	4550
PL50T.150	5000/500	380-1360	1500	1150	100/150	365	780	80	42	416	229	3	4640
PL50T.155	5000/500	380-1410	1550	1150	100/150	365	780	80	42	416	232	3	4730
PL50T.160	5000/500	380-1460	1600	1150	100/150	365	780	80	42	416	240	3	4850
PL50T.165	5000/500	380-1510	1650	1300	100/150	365	780	80	42	416	245	3	4930

Attachment not recommended for clamping between forks

Advantages

- Easy to install
- Expertly manufactured
- Superior mechanical strength
- Forks positioning with flow divider
- Minimum LL thickness

Available on request

- Load backrest
- Upper and lower bushing for hard work

PK

2500 kg
5000 kg

Fork positioner with FEM fork carriers without sideshifter

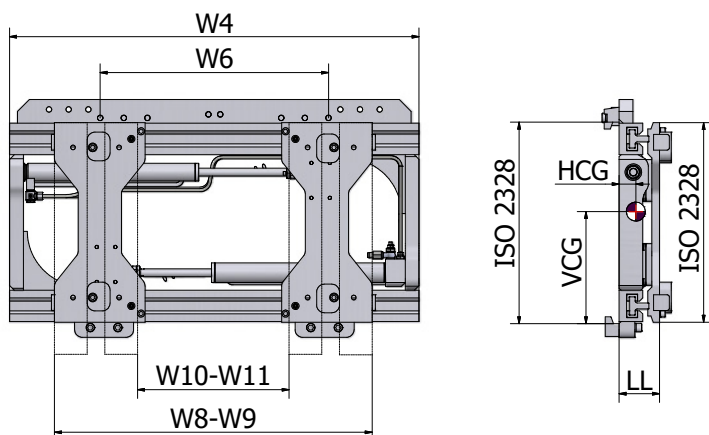

Product info

- W6 – Minimum carriage width
- Technical data without forks
- Maximum advised fork length: 2400 mm
- Linked cylinders provide perfect synchronisation
- Without sideshifter
- With double rugged T-Bar design
- With low friction nylon bearings



Model	Capacity	W10-W11 mm	W8-W9 mm	W4 mm	W6 mm	LL mm	HCG mm	VCG mm	Weight kg	ISO 2328	RRP
	kg/mm										Euro
★ PK25.098	2500/600	50-660	475-1085	980	680	96	39	232	120	2	4460
★ PK25.104	2500/600	50-720	475-1145	1040	710	96	38	233	122	2	4520
PK25.110	2500/600	50-780	475-1205	1100	710	96	38	234	128	2	4560
★ PK25.115	2500/600	50-830	475-1255	1150	820	96	37	235	131	2	4640
PK25.125	2500/600	50-930	475-1355	1250	860	96	37	237	138	2	4800
PK25.135	2500/600	50-1030	475-1455	1350	960	96	36	238	146	2	4870
PK35.104	3500/600	50-720	475-1145	1040	710	103	42	285	143	3	4550
★ PK35.110	3500/600	50-780	475-1205	1100	710	103	42	286	147	3	4620
★ PK35.115	3500/600	50-830	475-1255	1150	820	103	41	287	150	3	4690
PK35.125	3500/600	50-930	475-1355	1250	860	103	41	289	157	3	4810
★ PK35.135	3500/600	50-1030	475-1455	1350	960	103	40	290	164	3	4920
PK35.155	3500/600	50-1230	475-1655	1550	1120	103	39	293	178	3	5150
PK35.165	3500/600	50-1330	475-1755	1650	1320	103	38	294	184	3	5260
PK50.110	5000/600	60-790	480-1310	1100	920	118	43	272	204	3	5290
PK50.115	5000/600	60-840	480-1260	1150	1010	118	43	272	209	3	5370
PK50.130	5000/600	60-990	480-1410	1300	1165	118	43	270	224	3	5530
★ PK50.135	5000/600	60-1040	480-1460	1350	1165	118	43	270	229	3	5660
★ PK50.145	5000/600	60-1140	480-1560	1450	1220	118	43	270	239	3	5770
PK50.150	5000/600	60-1190	480-1610	1500	1320	118	43	270	244	3	5830
PK50.155	5000/600	60-1240	480-1660	1550	1320	118	43	270	249	3	5880
PK50.175	5000/600	60-1440	480-1860	1750	1520	118	43	270	269	3	6520
PK50.185	5000/600	60-1540	480-1960	1850	1670	118	43	270	279	3	6630

★ Suggested selection

Advantages

- Easy installation on (triple) forklift masts
- Excellent forks synchrony
- Easy mounting of forks
- Increased safety with better visibility through the frame
- Easy-to-mount fork pockets
- PK25 design accepts 80, 100, 120, 125, 130, 150 mm fork widths
- PK35 design accepts 80, 100, 120, 125, 130, 150 mm fork widths
- PK50 design accepts 120, 125, 130, 150, 180, 200 mm fork widths

Available on request

- Load backrest

Fork positioner with FEM fork carriers without sideshifter

PK
6000 kg

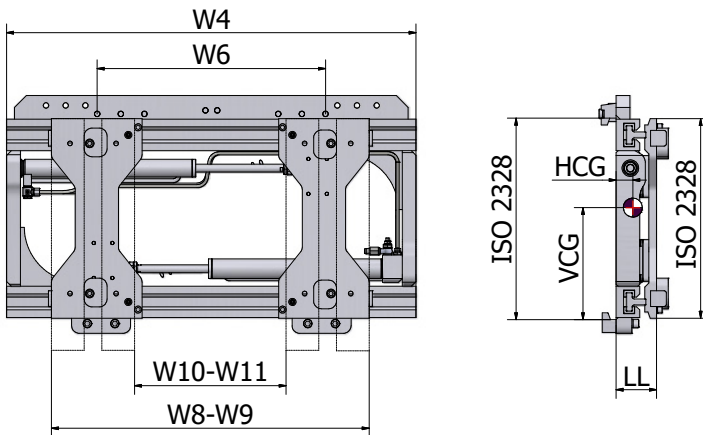

Product info

- W6 – Minimum carriage width
- Technical data without forks
- Maximum advised fork length: 2400 mm
- Without sideshifter
- Valve block with flow divider
- With double rugged T-Bar design
- With low friction nylon bearings



Model	Capacity	W10-W11 mm	W8-W9 mm	W4 mm	W6 mm	LL mm	HCG mm	VCG mm	Weight kg	ISO 2328	RRP
	kg/mm										Euro
PK60.135	6000/600	60–870	580–1390	1350	1100	123	48	353	293	4	7900
PK60.145	6000/600	60–970	580–1490	1450	1100	123	48	353	303	4	7900
PK60.160	6000/600	60–1120	580–1640	1600	1200	123	47	353	314	4	8030
PK60.165	6000/600	60–1170	580–1690	1650	1250	123	47	353	326	4	8080
PK60.170	6000/600	60–1220	580–1740	1700	1300	123	46	354	331	4	8120
PK60.180	6000/600	60–1320	580–1840	1800	1400	123	45	354	335	4	8270
PK60.185	6000/600	60–1370	580–1890	1850	1450	123	45	354	340	4	8830

Advantages

- Excellent forks synchrony
- Easy installation on (triple) forklift masts
- Easy mounting of forks
- Increased safety with better visibility through the frame
- Easy-to-mount fork pockets
- PK60 design accepts 130, 150, 180, 200 mm fork widths

Available on request

- Load backrest
- Model with connection hoses
- Model with quick connection hoses

PK.SIN**2500 kg
5000 kg**

Fork positioner with FEM fork carriers without sideshifter

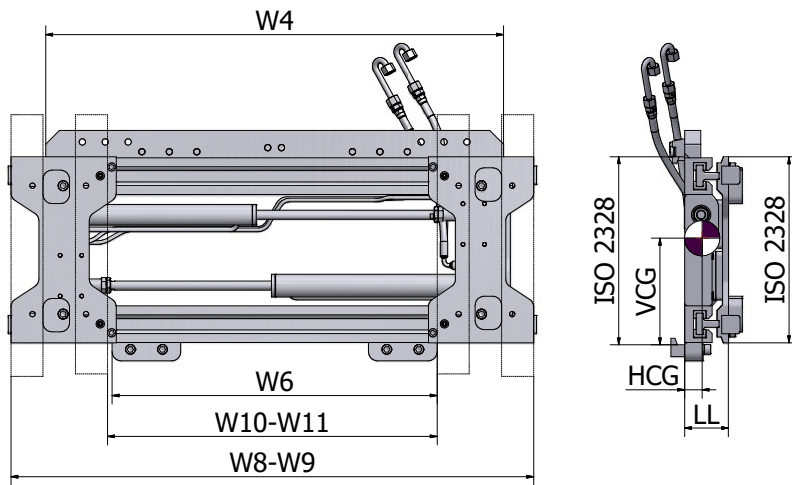

Product info

- W6 – Minimum carriage width
- Technical data without forks
- Maximum advised fork length: 2400 mm
- Linked cylinders provide perfect synchronisation
- Without sideshifter
- High termination kit yet installed
- With double rugged T-Bar design
- With low friction nylon bearings



Model	Capacity	W10-W11 mm	W8-W9 mm	W4 mm	W6 mm	LL mm	HCG mm	VCG mm	Weight kg	ISO 2328	RRP
	kg/mm										Euro
PK25.098.SIN	2500/600	50-660	475-1085	980	680	96	39	232	120	2	4750
PK25.104.SIN	2500/600	50-720	475-1145	1040	710	96	38	233	122	2	4820
PK25.110.SIN	2500/600	50-780	475-1205	1100	710	96	38	234	128	2	4860
PK25.115.SIN	2500/600	50-830	475-1255	1150	820	96	37	235	131	2	4930
PK25.125.SIN	2500/600	50-930	475-1355	1250	860	96	37	237	138	2	5090
PK25.135.SIN	2500/600	50-1030	475-1455	1350	960	96	36	238	146	2	5160
PK35.104.SIN	3500/600	50-720	475-1145	1040	710	103	42	285	143	3	4850
PK35.110.SIN	3500/600	50-780	475-1205	1100	710	103	42	286	147	3	4910
PK35.115.SIN	3500/600	50-830	475-1255	1150	820	103	41	287	150	3	4980
PK35.125.SIN	3500/600	50-930	475-1355	1250	860	103	41	289	157	3	5100
PK35.135.SIN	3500/600	50-1030	475-1455	1350	960	103	40	290	164	3	5210
PK35.155.SIN	3500/600	50-1230	475-1655	1550	1120	103	39	293	178	3	5440
PK35.165.SIN	3500/600	50-1330	475-1755	1650	1320	103	38	294	184	3	5550
PK50.110.SIN	5000/600	60-790	480-1310	1100	920	120	43	272	204	3	5590
PK50.115.SIN	5000/600	60-840	480-1260	1150	1010	120	43	272	209	3	5660
PK50.130.SIN	5000/600	60-990	480-1410	1300	1165	120	43	270	224	3	5820
PK50.135.SIN	5000/600	60-1040	480-1460	1350	1165	120	43	270	229	3	5950
PK50.145.SIN	5000/600	60-1140	480-1560	1450	1220	120	43	270	239	3	6060
PK50.150.SIN	5000/600	60-1190	480-1610	1500	1320	120	43	270	244	3	6120
PK50.155.SIN	5000/600	60-1240	480-1660	1550	1320	120	43	270	249	3	6170
PK50.175.SIN	5000/600	60-1440	480-1860	1750	1520	120	43	270	269	3	6810
PK50.185.SIN	5000/600	60-1540	480-1960	1850	1670	120	43	270	279	3	6920

Advantages

- Excellent forks synchrony
- Easy installation on (triple) forklift masts
- Easy mounting of forks
- Increased safety with better visibility through the frame
- Easy-to-mount fork pockets
- PK25 design accepts 80, 100, 120, 125, 130, 150 mm fork widths
- PK35 design accepts 80, 100, 120, 125, 130, 150 mm fork widths
- PK50 design accepts 120, 125, 130, 150, 180, 200 mm fork widths

Available on request

- Load backrest

Fork positioner with FEM fork carriers without sideshifter

PK.SIN

6000 kg

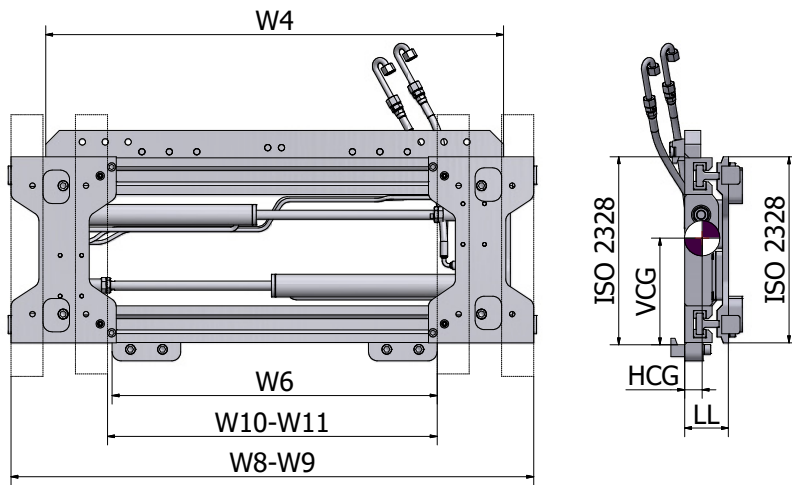

Product info

- W6 – Minimum carriage width
- Technical data without forks
- Maximum advised fork length: 2400 mm
- Without sideshifter
- High termination kit yet installed
- Valve block with flow divider
- With double rugged T-Bar design
- With low friction nylon bearings



Model	Capacity	W10-W11	W8-W9	W4	W6	LL	HCG	VCG	Weight	ISO 2328	RRP
	kg/mm										mm
PK60.135.SIN	6000/600	60-870	580-1390	1350	1100	123	48	353	293	4	8100
PK60.145.SIN	6000/600	60-970	580-1490	1450	1100	123	48	353	303	4	8100
PK60.160.SIN	6000/600	60-1120	580-1640	1600	1200	123	47	353	314	4	8240
PK60.165.SIN	6000/600	60-1170	580-1690	1650	1250	123	47	353	326	4	8280
PK60.170.SIN	6000/600	60-1220	580-1740	1700	1300	123	46	354	331	4	8330
PK60.180.SIN	6000/600	60-1320	580-1840	1800	1400	123	45	354	335	4	8470
PK60.185.SIN	6000/600	60-1370	580-1890	1850	1450	123	45	354	340	4	9020

Advantages

- Excellent forks synchrony
- Easy installation on (triple) forklift masts
- Easy mounting of forks
- Increased safety with better visibility through the frame
- Easy-to-mount fork pockets
- PK60 design accepts 130, 150, 180, 200 mm fork widths

Available on request

- Load backrest

PK-TS

2500 kg
5000 kg

Fork positioner with FEM fork carriers with separate sideshifter

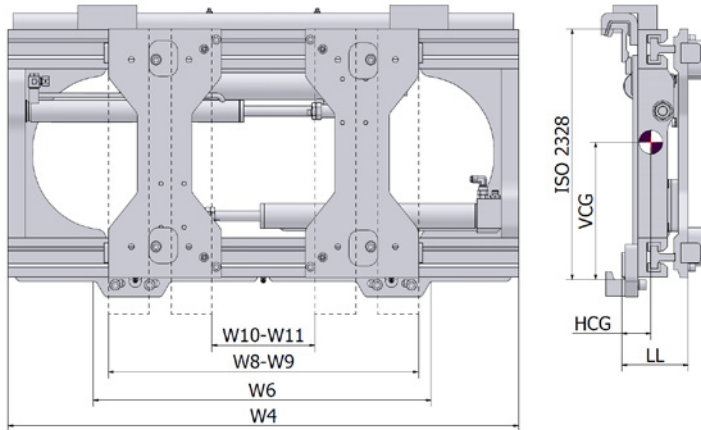

Product info

- W6 – Minimum carriage width
- Technical data without forks
- Maximum advised fork length: 2400 mm
- Total sideshifter stroke: 100 + 100 mm
- With double rugged T-Bar design
- With low friction nylon bearings
- Linked cylinders for perfect synchronisation
- Upper and lower bushings with grease nipples



Model	Capacity	W10-W11 mm	W8-W9 mm	W4 mm	W6 mm	LL mm	HCG mm	VCG mm	Weight kg	ISO 2328	RRP
	kg/mm										Euro
★ PK25TS.098	2500/600	50–660	475–1085	980	880	113	54	231	125	2	4590
★ PK25TS.104	2500/600	50–720	475–1145	1040	910	113	52	231	128	2	4690
PK25TS.110	2500/600	50–780	475–1205	1100	910	113	51	231	133	2	4700
★ PK25TS.115	2500/600	50–830	475–1255	1150	1010	113	50	231	137	2	4780
PK25TS.125	2500/600	50–930	475–1355	1250	1165	113	49	231	142	2	4940
PK25TS.135	2500/600	50–1030	475–1455	1350	1165	113	48	231	147	2	5010
PK35TS.104	3500/600	50–720	475–1145	1040	910	135	59	281	178	3	4870
★ PK35TS.110	3500/600	50–780	475–1205	1100	910	135	59	281	182	3	4940
★ PK35TS.115	3500/600	50–830	475–1255	1150	1010	135	58	281	187	3	5010
PK35TS.125	3500/600	50–930	475–1355	1250	1065	135	57	280	195	3	5130
★ PK35TS.135	3500/600	50–1030	475–1455	1350	1165	135	56	279	205	3	5240
PK35TS.155	3500/600	50–1230	475–1655	1550	1320	135	55	279	220	3	5470
PK35TS.165	3500/600	50–1330	475–1755	1650	1520	135	55	279	228	3	5580
PK50TS.110	5000/600	60–790	480–1310	1100	920	150	67	281	227	3	5620
PK50TS.115	5000/600	60–840	480–1260	1150	1010	150	66	281	232	3	5700
PK50TS.130	5000/600	60–990	480–1410	1300	1165	150	65	279	243	3	5860
★ PK50TS.135	5000/600	60–1040	480–1460	1350	1165	150	64	279	251	3	5990
★ PK50TS.145	5000/600	60–1140	480–1560	1450	1220	150	64	279	263	3	6100
PK50TS.150	5000/600	60–1190	480–1610	1500	1320	150	63	279	269	3	6160
PK50TS.155	5000/600	60–1240	480–1660	1550	1320	150	63	279	275	3	6220
PK50TS.175	5000/600	60–1440	480–1860	1750	1520	150	62	279	299	3	6860
PK50TS.185	5000/600	60–1540	480–1960	1850	1670	150	61	279	311	3	6960

★ Suggested selection

Advantages

- Excellent forks synchrony
- Easy installation on (triple) forklift masts
- Easy mounting of forks
- Increased safety with better visibility through the frame
- Easy-to-mount fork pockets
- PK25TS design accepts 80, 100, 120, 125, 130, 150 mm fork widths
- PK35TS design accepts 80, 100, 120, 125, 130, 150 mm fork widths
- PK50TS design accepts 120, 125, 130, 150, 180, 200 mm fork widths

Available on request

- Load backrest
- Model with high termination (.SIN)
- Model with connection hoses
- Model with quick connection hoses

Fork positioner with FEM fork carriers with separate sideshifter

PK-TS
6000 kg

Product info

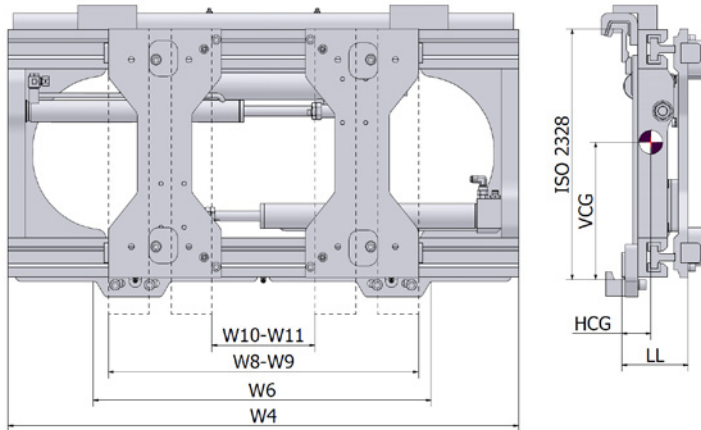

- W6 – Minimum carriage width
- Technical data without forks
- Maximum advised fork length: 2400 mm
- Total sideshifter stroke: 150 + 150 mm
- With double rugged T-Bar design
- With low friction nylon bearings
- Valve block with flow divider
- Upper and lower bushings with grease nipples



Model	Capacity	W10-W11	W8-W9	W4	W6	LL	HCG	VCG	Weight	ISO 2328	RRP
	kg/mm								kg		Euro
PK60TS.135	6000/600	60–870	580–1390	1350	1100	163	72	362	340	4	8810
PK60TS.145	6000/600	60–970	580–1490	1450	1100	163	70	362	353	4	8810
PK60TS.160	6000/600	60–1120	580–1640	1600	1200	163	68	363	371	4	8950
PK60TS.165	6000/600	60–1170	580–1690	1650	1250	163	68	363	378	4	8990
PK60TS.170	6000/600	60–1220	580–1740	1700	1300	163	67	363	384	4	9040
PK60TS.180	6000/600	60–1320	580–1840	1800	1400	163	65	364	397	4	9190
PK60TS.185	6000/600	60–1370	580–1890	1850	1450	163	64	364	403	4	9750

Advantages

- Excellent forks synchrony
- Easy installation on (triple) forklift masts
- Easy mounting of forks
- Improved safety thanks to better visibility through the frame
- Easy-to-mount fork pockets
- PK60TS design accepts 130, 150, 180, 200 mm fork widths

Available on request

- Load backrest
- Model with high termination (.SIN)
- Model with connection hoses
- Model with quick connection hoses
- Total sideshifter stroke 100+100 for FEM 4

PK-TS.SIN**2500 kg
5000 kg**

Fork positioner with FEM fork carriers with separate sideshifter

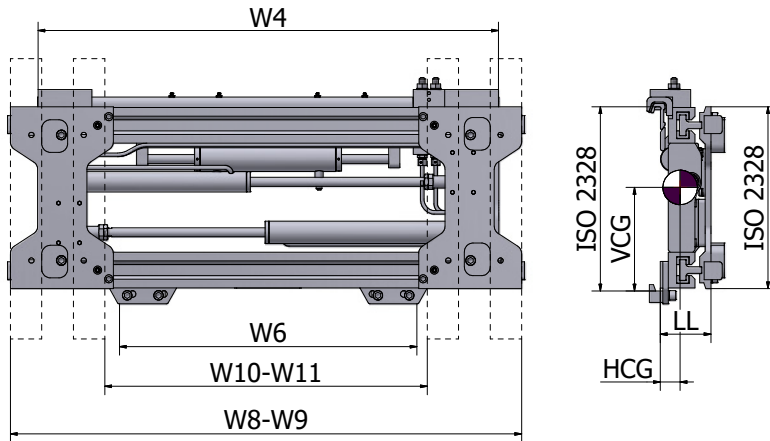

Product info

- W6 – Minimum carriage width
- Technical data without forks
- Maximum advised fork length: 2400 mm
- Linked cylinders for perfect synchronisation
- Total sideshifter stroke: 100 + 100 mm (FEM 2–FEM 3)
- High termination kit yet installed
- With double rugged T-Bar design
- With low friction nylon bearings
- Upper and lower bushings with grease nipples



Model	Capacity	W10-W11 mm	W8-W9 mm	W4 mm	W6 mm	LL mm	HCG mm	VCG mm	Weight kg	ISO 2328	RRP
	kg/mm										Euro
PK25TS.098.SIN	2500/600	50-660	475-1085	980	880	113	54	231	125	2	4890
PK25TS.104.SIN	2500/600	50-720	475-1145	1040	910	113	52	231	128	2	4950
PK25TS.110.SIN	2500/600	50-780	475-1205	1100	910	113	51	231	133	2	5000
PK25TS.115.SIN	2500/600	50-830	475-1255	1150	1010	113	50	231	137	2	5070
PK25TS.125.SIN	2500/600	50-930	475-1355	1250	1165	113	49	231	142	2	5230
PK25TS.135.SIN	2500/600	50-1030	475-1455	1350	1165	113	48	231	147	2	5300
PK35TS.104.SIN	3500/600	50-720	475-1145	1040	910	135	59	281	178	3	5170
PK35TS.110.SIN	3500/600	50-780	475-1205	1100	910	135	59	281	182	3	5230
PK35TS.115.SIN	3500/600	50-830	475-1255	1150	1010	135	58	281	187	3	5300
PK35TS.125.SIN	3500/600	50-930	475-1355	1250	1065	135	57	280	195	3	5420
PK35TS.135.SIN	3500/600	50-1030	475-1455	1350	1165	135	56	279	205	3	5530
PK35TS.155.SIN	3500/600	50-1230	475-1655	1550	1320	135	55	279	220	3	5760
PK35TS.165.SIN	3500/600	50-1330	475-1755	1650	1520	135	55	279	228	3	5870
PK50TS.110.SIN	5000/600	60-790	480-1310	1100	920	152	67	281	227	3	5920
PK50TS.115.SIN	5000/600	60-840	480-1260	1150	1010	152	66	281	232	3	5990
PK50TS.130.SIN	5000/600	60-990	480-1410	1300	1165	152	65	279	243	3	6150
PK50TS.135.SIN	5000/600	60-1040	480-1460	1350	1165	152	64	279	251	3	6280
PK50TS.145.SIN	5000/600	60-1140	480-1560	1450	1220	152	64	279	263	3	6390
PK50TS.150.SIN	5000/600	60-1190	480-1610	1500	1320	152	63	279	269	3	6450
PK50TS.155.SIN	5000/600	60-1240	480-1660	1550	1320	152	63	279	275	3	6510
PK50TS.175.SIN	5000/600	60-1440	480-1860	1750	1520	152	62	279	299	3	7140
PK50TS.185.SIN	5000/600	60-1540	480-1960	1850	1670	152	61	279	311	3	7250

Advantages

- Excellent forks synchrony
- Easy installation on (triple) forklift masts
- Easy mounting of forks
- Improved safety thanks to better visibility through the frame
- Easy-to-mount fork pockets
- PK25TS design accepts 80, 100, 120, 125, 130, 150 mm fork widths
- PK35TS design accepts 80, 100, 120, 125, 130, 150 mm fork widths
- PK50TS design accepts 120, 125, 130, 150, 180, 200 mm fork widths

Available on request

- Load backrest
- Model with connection hoses
- Model with quick connection hoses

Fork positioner with FEM fork carriers with separate sideshifter

PK-TS.SIN

6000 kg

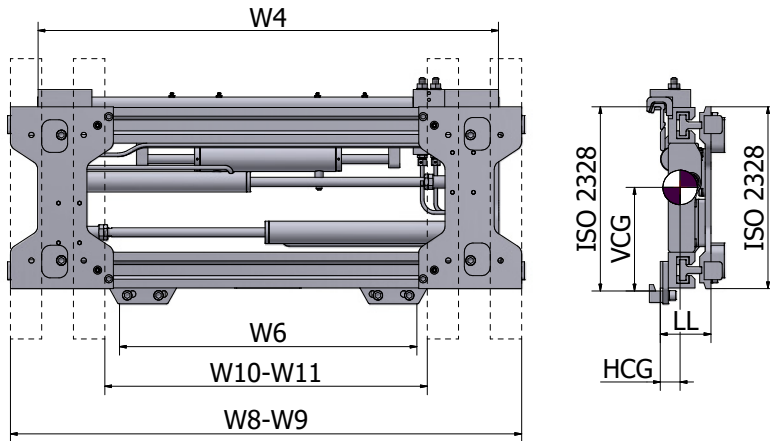

Product info

- W6 – Minimum carriage width
- Technical data without forks
- Maximum advised fork length: 2400 mm
- Total sideshifter stroke: 150 + 150 mm (FEM 4)
- High termination kit installed
- With double rugged T-Bar design
- With low friction nylon bearings
- Upper and lower bushings with grease nipples
- Valve block with flow divider



Model	Capacity	W10-W11 mm	W8-W9 mm	W4 mm	W6 mm	LL mm	HCG mm	VCG mm	Weight kg	ISO 2328	RRP
	kg/mm										Euro
PK60TS.135.SIN	6000/600	60-870	580-1390	1350	1100	163	72	362	340	4	9020
PK60TS.145.SIN	6000/600	60-970	580-1490	1450	1100	163	70	362	353	4	9020
PK60TS.160.SIN	6000/600	60-1120	580-1640	1600	1200	163	68	363	371	4	9150
PK60TS.165.SIN	6000/600	60-1170	580-1690	1650	1250	163	68	363	378	4	9200
PK60TS.170.SIN	6000/600	60-1220	580-1740	1700	1300	163	67	363	384	4	9240
PK60TS.180.SIN	6000/600	60-1320	580-1840	1800	1400	163	65	364	397	4	9390
PK60TS.185.SIN	6000/600	60-1370	580-1890	1850	1450	163	64	364	403	4	9940

Advantages

- Excellent forks synchrony
- Easy installation on (triple) forklift masts
- Easy mounting of forks
- Improved safety thanks to better visibility through the frame
- Easy-to-mount fork pockets
- PK60TS design accepts 130, 150, 180, 200 mm fork widths

Available on request

- Load backrest
- Model with connection hoses
- Model with quick connection hoses
- Totale sideshifter stroke 100+100 for FEM 4

PKF

2500 kg
5000 kg

Fork positioner with forks without sideshifter

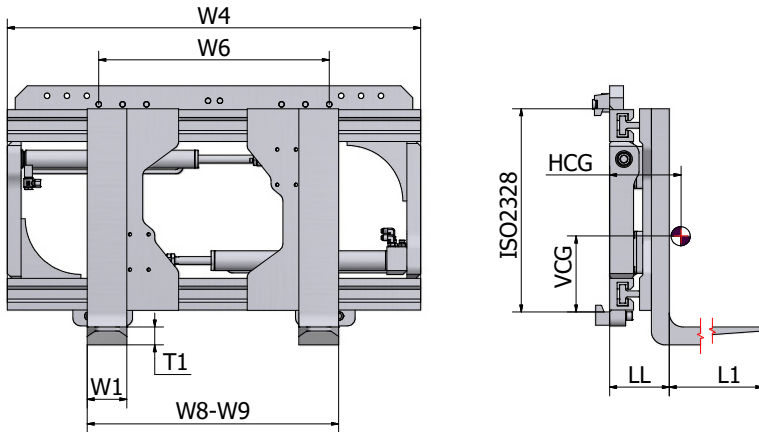

Product info

- W6 – Minimum carriage width
- Technical data without forks
- Maximum advised fork length: 2400 mm
- Linked cylinders provide perfect synchronisation
- Without sideshifter
- With double rugged T-Bar design
- With low friction nylon bearings



Model	Capacity	W8-W9	W4	W6	Forks L1 x W1 x T1	LL	HCG	VCG	Weight	ISO 2328	RRP
	kg/mm								kg		Euro
★ PKF25.098	2500/600	475–1085	980	680	1200 x 100 x 45	141	235	143	234	2A	5600
★ PKF25.104	2500/600	475–1145	1040	710	1200 x 100 x 45	141	233	144	237	2A	5660
PKF25.110	2500/600	475–1205	1100	710	1200 x 100 x 45	141	232	145	242	2A	5710
★ PKF25.115	2500/600	475–1255	1150	820	1200 x 100 x 45	141	231	146	246	2A	5780
PKF25.125	2500/600	475–1355	1250	860	1200 x 100 x 45	141	230	147	251	2A	5940
PKF25.135	2500/600	475–1455	1350	960	1200 x 100 x 45	141	229	148	256	2A	6010
PKF35.104	3500/600	475–1145	1040	710	1200 x 120 x 50	153	238	196	276	3A	6250
★ PKF35.110	3500/600	475–1205	1100	710	1200 x 120 x 50	153	238	197	280	3A	6290
★ PKF35.115	3500/600	475–1255	1150	820	1200 x 120 x 50	153	237	198	282	3A	6340
PKF35.125	3500/600	475–1355	1250	860	1200 x 120 x 50	153	237	200	287	3A	6460
★ PKF35.135	3500/600	475–1455	1350	960	1200 x 120 x 50	153	236	201	292	3A	6570
PKF35.155	3500/600	475–1655	1550	1120	1200 x 120 x 50	153	235	204	302	3A	6800
PKF35.165	3500/600	475–1755	1650	1320	1200 x 120 x 50	153	234	205	310	3A	6920
PKF50.110	5000/600	480–1310	1100	920	1200 x 150 x 60	178	260	255	431	3A	7381
PKF50.115	5000/600	480–1260	1150	1010	1200 x 150 x 60	178	260	255	436	3A	7450
PKF50.130	5000/600	480–1410	1300	1165	1200 x 150 x 60	178	260	167	451	3A	7610
★ PKF50.135	5000/600	480–1460	1350	1165	1200 x 150 x 60	178	260	167	456	3A	7738
★ PKF50.145	5000/600	480–1560	1450	1220	1200 x 150 x 60	178	260	253	466	3A	7850
PKF50.150	5000/600	480–1610	1500	1320	1200 x 150 x 60	178	260	253	471	3A	7914
PKF50.155	5000/600	480–1660	1550	1320	1200 x 150 x 60	178	260	253	476	3A	7968
PKF50.175	5000/600	480–1860	1750	1520	1200 x 150 x 60	178	260	253	496	3A	8608
PKF50.185	5000/600	480–1960	1850	1670	1200 x 150 x 60	178	260	253	506	3A	8715

★ Suggested selection

Advantages

- Excellent forks synchrony
- Easy installation on (triple) forklift masts
- Easy mounting of forks
- Improved safety thanks to better visibility through the frame
- Easy-to-mount fork pockets

Available on request

- Load backrest
- Other fork sizes
- Model with minimum internal opening of 5 mm
- Model with bolted forks
- Model with connection hoses
- Model with quick connection hoses

Fork positioner with forks without sideshifter

PKF
6000 kg

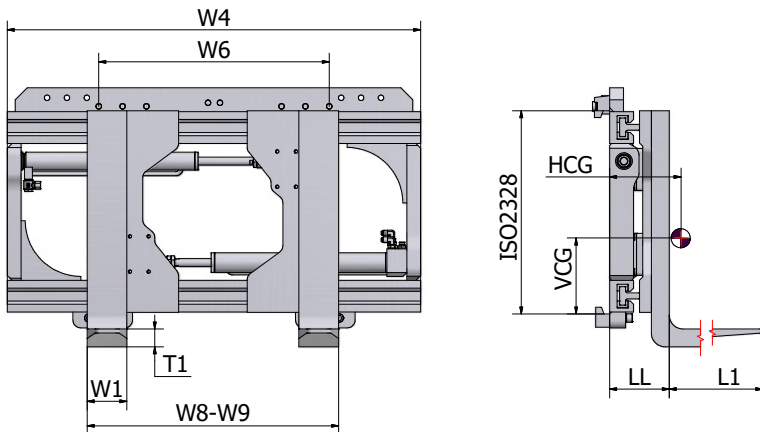

Product info

- W6 – Minimum carriage width
- Technical data without forks
- Maximum advised fork length: 2400 mm
- Without sideshifter
- With double rugged T-Bar design
- With low friction nylon bearings
- Valve block with flow divider



Model	Capacity	W8-W9	W4	W6	Forks L1 x W1 x T1	LL	HCG	VCG	Weight	ISO 2328	RRP
	kg/mm										mm
PKF60.135	6000/600	560–1370	1350	1100	1200 x 150 x 60	183	236	218	539	4A	10972
PKF60.145	6000/600	560–1470	1450	1100	1200 x 150 x 60	183	236	218	549	4A	10972
PKF60.160	6000/600	560–1620	1600	1200	1200 x 150 x 60	183	235	218	560	4A	11108
PKF60.165	6000/600	560–1670	1650	1250	1200 x 150 x 60	183	235	218	572	4A	11153
PKF60.170	6000/600	560–1720	1700	1300	1200 x 150 x 60	183	234	219	577	4A	11198
PKF60.180	6000/600	560–1820	1800	1400	1200 x 150 x 60	183	233	219	581	4A	11343
PKF60.185	6000/600	560–1870	1850	1450	1200 x 150 x 60	183	233	219	586	4A	11898

Advantages

- Excellent forks synchrony
- Easy installation on (triple) forklift masts
- Easy mounting of forks
- Improved safety thanks to better visibility through the frame
- Easy-to-mount fork pockets

Available on request

- Load backrest
- Other fork sizes
- Model with minimum internal opening of 5 mm
- Model with bolted forks
- Model with connection hoses
- Model with quick connection hoses

PKF.SIN

2500 kg
5000 kg

Fork positioner with forks without sideshifter

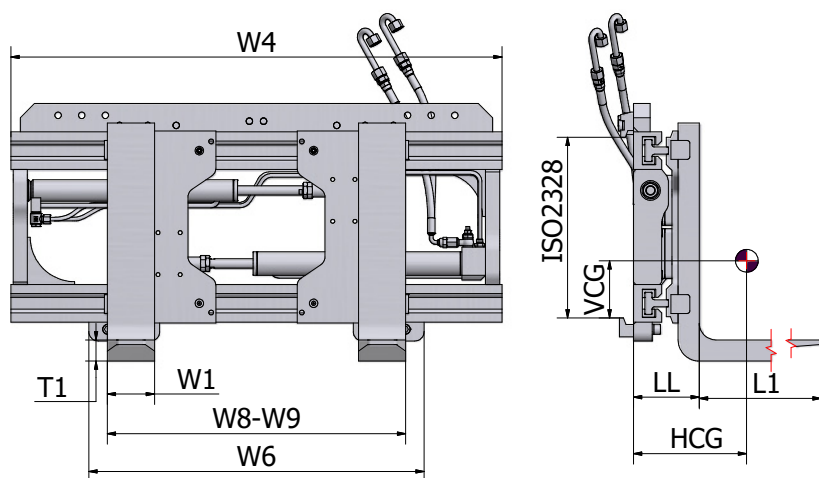

Product info

- W6 – Minimum carriage width
- Technical data without forks
- Maximum advised fork length: 2400 mm
- Linked cylinders for perfect synchronisation
- Without sideshifter
- High termination kit yet installed
- With double rugged T-Bar design
- With low friction nylon bearings



Model	Capacity	W8-W9	W4	W6	Forks L1 x W1 x T1	LL	HCG	VCG	Weight	ISO 2328	RRP
	kg/mm								kg		Euro
PKF25.098.SIN	2500/600	475-1085	980	680	1200 x 100 x 45	141	235	143	234	2A	5880
PKF25.104.SIN	2500/600	475-1145	1040	710	1200 x 100 x 45	141	233	144	237	2A	5940
PKF25.110.SIN	2500/600	475-1205	1100	710	1200 x 100 x 45	141	232	145	242	2A	5990
PKF25.115.SIN	2500/600	475-1255	1150	820	1200 x 100 x 45	141	231	146	246	2A	6060
PKF25.125.SIN	2500/600	475-1355	1250	860	1200 x 100 x 45	141	230	147	251	2A	6210
PKF25.135.SIN	2500/600	475-1455	1350	960	1200 x 100 x 45	141	229	148	256	2A	6280
PKF35.104.SIN	3500/600	475-1145	1040	710	1200 x 120 x 50	153	238	196	276	3A	6520
PKF35.110.SIN	3500/600	475-1205	1100	710	1200 x 120 x 50	153	238	197	280	3A	6580
PKF35.115.SIN	3500/600	475-1255	1150	820	1200 x 120 x 50	153	237	198	282	3A	6650
PKF35.125.SIN	3500/600	475-1355	1250	860	1200 x 120 x 50	153	237	200	287	3A	6770
PKF35.135.SIN	3500/600	475-1455	1350	960	1200 x 120 x 50	153	236	201	292	3A	6880
PKF35.155.SIN	3500/600	475-1655	1550	1120	1200 x 120 x 50	153	235	204	302	3A	7110
PKF35.165.SIN	3500/600	475-1755	1650	1320	1200 x 120 x 50	153	234	205	310	3A	7230
PKF50.110.SIN	5000/600	480-1310	1100	920	1200 x 150 x 60	180	260	255	431	3A	7650
PKF50.115.SIN	5000/600	480-1260	1150	1010	1200 x 150 x 60	180	260	255	436	3A	7720
PKF50.130.SIN	5000/600	480-1410	1300	1165	1200 x 150 x 60	180	260	167	451	3A	7880
PKF50.135.SIN	5000/600	480-1460	1350	1165	1200 x 150 x 60	180	260	167	456	3A	8010
PKF50.145.SIN	5000/600	480-1560	1450	1220	1200 x 150 x 60	180	260	253	466	3A	8120
PKF50.150.SIN	5000/600	480-1610	1500	1320	1200 x 150 x 60	180	260	253	471	3A	8180
PKF50.155.SIN	5000/600	480-1660	1550	1320	1200 x 150 x 60	180	260	253	476	3A	8240
PKF50.175.SIN	5000/600	480-1860	1750	1520	1200 x 150 x 60	180	260	253	496	3A	8870
PKF50.185.SIN	5000/600	480-1960	1850	1670	1200 x 150 x 60	180	260	253	506	3A	8980

Advantages

- Excellent forks synchrony
- Easy installation on (triple) forklift masts
- Improved safety thanks to better visibility through the frame
- Easy-to-mount fork pockets

Available on request

- Load backrest
- Other fork sizes
- Model with minimum internal opening of 5 mm
- Model with bolted forks
- Model with connection hoses
- Model with quick connection hoses

Fork positioner with forks without sideshifter

PKF.SIN

6000 kg

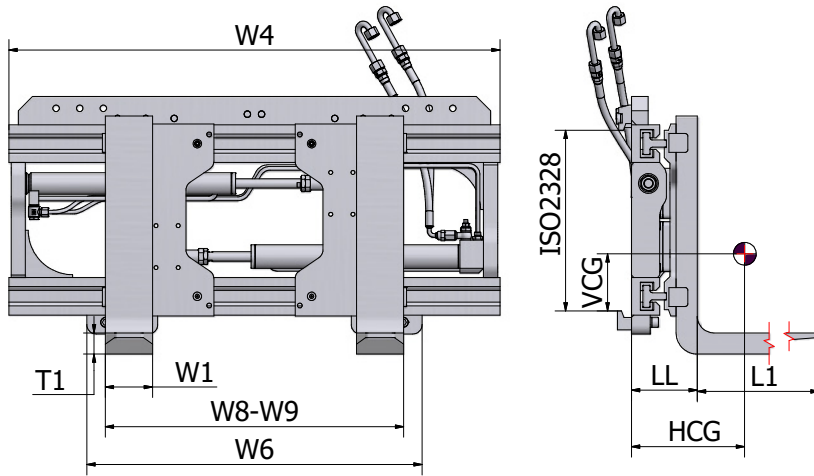

Product info

- W6 – Minimum carriage width
- Technical data without forks
- Maximum advised fork length: 2400 mm
- Without sideshifter
- With double rugged T-Bar design
- With low friction nylon bearings



Model	Capacity	W8-W9	W4	W6	Forks L1 x W1 x T1	LL	HCG	VCG	Weight	ISO 2328	RRP
	kg/mm								mm		mm
PKF60.135.SIN	6000/600	560-1370	1350	1100	1200 x 150 x 60	183	236	218	539	4A	11230
PKF60.145.SIN	6000/600	560-1470	1450	1100	1200 x 150 x 60	183	236	218	549	4A	11230
PKF60.160.SIN	6000/600	560-1620	1600	1200	1200 x 150 x 60	183	235	218	560	4A	11370
PKF60.165.SIN	6000/600	560-1670	1650	1250	1200 x 150 x 60	183	235	218	572	4A	11410
PKF60.170.SIN	6000/600	560-1720	1700	1300	1200 x 150 x 60	183	234	219	577	4A	11460
PKF60.180.SIN	6000/600	560-1820	1800	1400	1200 x 150 x 60	183	233	219	581	4A	11600
PKF60.185.SIN	6000/600	560-1870	1850	1450	1200 x 150 x 60	183	233	219	586	4A	12150

Advantages

- Excellent forks synchrony
- Easy installation on (triple) forklift masts
- Improved safety thanks to better visibility through the frame
- Easy-to-mount fork pockets

Available on request

- Load backrest
- Other fork sizes
- Model with minimum internal opening of 5 mm
- Model with bolted forks
- Model with connection hoses
- Model with quick connection hoses

PKF-TS

2500 kg
5000 kg

Fork positioner with forks with separate sideshifter

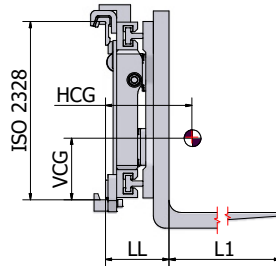
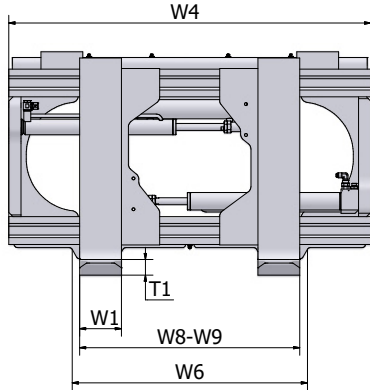

Product info

- W6 – Minimum carriage width
- Technical data without forks
- Maximum advised fork length: 2400 mm
- Linked cylinders for perfect synchronisation
- Total sideshifter stroke: 100 + 100 mm
- With double rugged T-Bar design
- With low friction nylon bearings
- Upper and lower bushings with grease nipples



Model	Capacity	W8-W9	W4	W6	Forks L1 x W1 x T1	LL	HCG	VCG	Weight	ISO 2328	RRP
	kg/mm								mm		mm
★ PKF25TS.098	2500/600	475–1085	980	880	1200 x 100 x 45	158	252	142	243	2A	5860
★ PKF25TS.104	2500/600	475–1145	1040	910	1200 x 100 x 45	158	250	142	246	2A	5930
PKF25TS.110	2500/600	475–1205	1100	910	1200 x 100 x 45	158	249	142	251	2A	5980
★ PKF25TS.115	2500/600	475–1255	1150	1010	1200 x 100 x 45	158	248	142	255	2A	5920
PKF25TS.125	2500/600	475–1355	1250	1165	1200 x 100 x 45	158	247	142	260	2A	6080
PKF25TS.135	2500/600	475–1455	1350	1165	1200 x 100 x 45	158	246	142	265	2A	6150
PKF35TS.104	3500/600	475–1145	1040	910	1200 x 120 x 50	185	239	176	321	3A	6550
★ PKF35TS.110	3500/600	475–1205	1100	910	1200 x 120 x 50	185	238	176	325	3A	6610
★ PKF35TS.115	3500/600	475–1255	1150	1010	1200 x 120 x 50	185	237	176	327	3A	6660
PKF35TS.125	3500/600	475–1355	1250	1065	1200 x 120 x 50	185	236	175	332	3A	6780
★ PKF35TS.135	3500/600	475–1455	1350	1165	1200 x 120 x 50	185	235	174	337	3A	6890
PKF35TS.155	3500/600	475–1655	1550	1320	1200 x 120 x 50	185	234	174	347	3A	7120
PKF35TS.165	3500/600	475–1755	1650	1520	1200 x 120 x 50	185	233	174	355	3A	7240
PKF50TS.110	5000/600	480–1310	1100	920	1200 x 150 x 60	210	278	180	456	3A	7714
PKF50TS.115	5000/600	480–1260	1150	1010	1200 x 150 x 60	210	277	180	461	3A	7784
PKF50TS.130	5000/600	480–1410	1300	1165	1200 x 150 x 60	210	276	178	472	3A	7944
★ PKF50TS.135	5000/600	480–1460	1350	1165	1200 x 150 x 60	210	275	178	480	3A	8072
★ PKF50TS.145	5000/600	480–1560	1450	1220	1200 x 150 x 60	210	275	178	492	3A	8184
PKF50TS.150	5000/600	480–1610	1500	1320	1200 x 150 x 60	210	274	178	498	3A	8248
PKF50TS.155	5000/600	480–1660	1550	1320	1200 x 150 x 60	210	274	178	504	3A	8301
PKF50TS.175	5000/600	480–1860	1750	1520	1200 x 150 x 60	210	273	178	528	3A	8941
PKF50TS.185	5000/600	480–1960	1850	1670	1200 x 150 x 60	210	272	178	540	3A	9048

★ Suggested selection

Advantages

- Excellent forks synchrony
- Easy installation on (triple) forklift masts
- Easy mounting of forks
- Improved safety thanks to better visibility through the frame

Available on request

- Load backrest
- Other fork sizes
- Model with minimum internal opening of 5 mm
- Model with High termination (.SIN)
- Model with connection hoses
- Model with quick connection hoses

Fork positioner with forks with separate sideshifter

PKF-TS

6000 kg

Product info

- W6 – Minimum carriage width
- Technical data without forks
- Maximum advised fork length: 2400 mm
- Total sideshifter stroke: 150 + 150 mm
- Valve block with flow divider
- Upper and lower bushings with grease nipples
- With double rugged T-Bar design
- With low friction nylon bearings

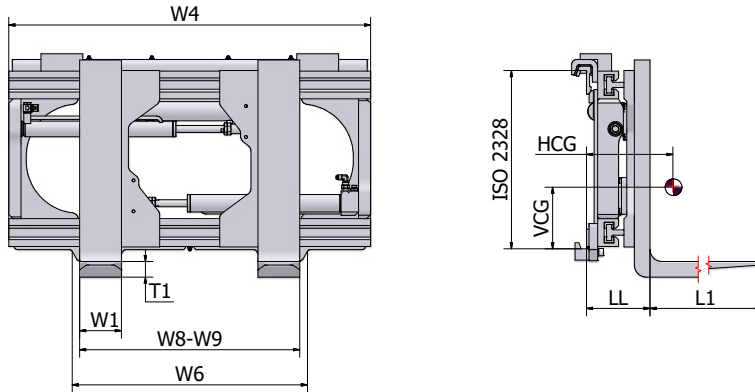

Model	Capacity	W8-W9	W4	W6	Forks L1 x W1 x T1	LL	HCG	VCG	Weight	ISO 2328	RRP
	kg/mm	mm	mm	mm	mm	mm	mm	mm	kg		Euro
PKF60TS.135	6000/600	560–1370	1350	1100	1200 x 150 x 60	223	235	362	588	4A	11892
PKF60TS.145	6000/600	560–1470	1450	1100	1200 x 150 x 60	223	233	362	601	4A	11892
PKF60TS.160	6000/600	560–1620	1600	1200	1200 x 150 x 60	223	231	363	619	4A	12028
PKF60TS.165	6000/600	560–1670	1650	1250	1200 x 150 x 60	223	231	363	626	4A	12073
PKF60TS.170	6000/600	560–1720	1700	1300	1200 x 150 x 60	223	230	363	632	4A	12118
PKF60TS.180	6000/600	560–1820	1800	1400	1200 x 150 x 60	223	228	248	645	4A	12263
PKF60TS.185	6000/600	560–1870	1850	1450	1200 x 150 x 60	220	227	248	651	4A	12818

Advantages

- Excellent forks synchrony
- Easy installation on (triple) forklift masts
- Easy mounting of forks
- Improved safety thanks to better visibility through the frame

Available on request

- Load backrest
- Other fork sizes
- Model with minimum internal opening of 5 mm
- Model with High termination (.SIN)
- Model with connection hoses
- Model with quick connection hoses
- Separate sideshifter 100+100 for FEM4

PKF-TS.SIN**2500 kg
5000 kg**

Fork positioner with forks with separate sideshifter

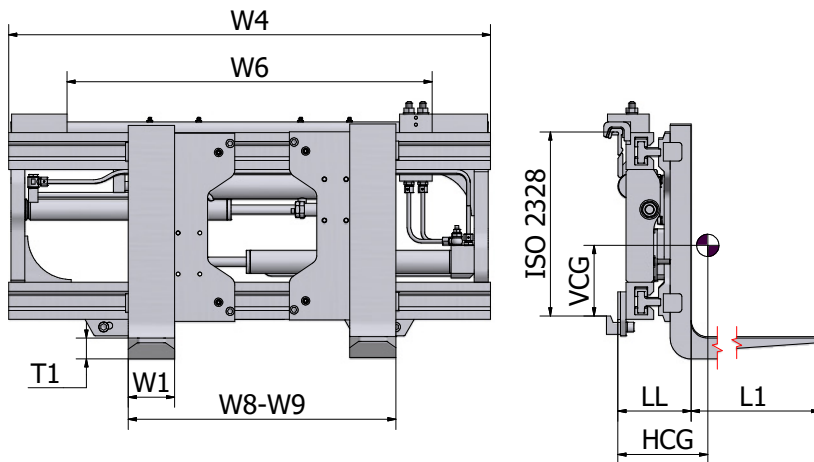

Product info

- W6 – Minimum carriage width
- Technical data without forks
- Maximum advised fork length: 2400 mm
- Linked cylinders for perfect synchronisation
- Total sideshifter stroke: 100 + 100 mm (FEM 2–FEM 3)
- High termination kit yet installed
- With double rugged T-Bar design
- With low friction nylon bearings
- Upper and lower bushings with grease nipples



Model	Capacity	W8-W9	W4	W6	Forks L1 x W1 x T1	LL	HCG	VCG	Weight	ISO 2328	RRP
	kg/mm								mm		mm
PKF25TS.098.SIN	2500/600	475-1085	980	880	1200 x 100 x 45	158	252	142	243	2A	6160
PKF25TS.104.SIN	2500/600	475-1145	1040	910	1200 x 100 x 45	158	250	142	246	2A	6230
PKF25TS.110.SIN	2500/600	475-1205	1100	910	1200 x 100 x 45	158	249	142	251	2A	6270
PKF25TS.115.SIN	2500/600	475-1255	1150	1010	1200 x 100 x 45	158	248	142	255	2A	6340
PKF25TS.125.SIN	2500/600	475-1355	1250	1165	1200 x 100 x 45	158	247	142	260	2A	6500
PKF25TS.135.SIN	2500/600	475-1455	1350	1165	1200 x 100 x 45	158	246	142	265	2A	6570
PKF35TS.104.SIN	3500/600	475-1145	1040	910	1200 x 120 x 50	185	239	176	321	3A	6850
PKF35TS.110.SIN	3500/600	475-1205	1100	910	1200 x 120 x 50	185	238	176	325	3A	6900
PKF35TS.115.SIN	3500/600	475-1255	1150	1010	1200 x 120 x 50	185	237	176	327	3A	6970
PKF35TS.125.SIN	3500/600	475-1355	1250	1065	1200 x 120 x 50	185	236	175	332	3A	7090
PKF35TS.135.SIN	3500/600	475-1455	1350	1165	1200 x 120 x 50	185	235	174	337	3A	7200
PKF35TS.155.SIN	3500/600	475-1655	1550	1320	1200 x 120 x 50	185	234	174	347	3A	7440
PKF35TS.165.SIN	3500/600	475-1755	1650	1520	1200 x 120 x 50	185	233	174	355	3A	7550
PKF50TS.110.SIN	5000/600	480-1310	1100	920	1200 x 150 x 60	209	278	180	456	3A	7980
PKF50TS.115.SIN	5000/600	480-1260	1150	1010	1200 x 150 x 60	209	277	180	461	3A	8050
PKF50TS.130.SIN	5000/600	480-1410	1300	1165	1200 x 150 x 60	209	276	178	472	3A	8210
PKF50TS.135.SIN	5000/600	480-1460	1350	1165	1200 x 150 x 60	209	275	178	480	3A	8340
PKF50TS.145.SIN	5000/600	480-1560	1450	1220	1200 x 150 x 60	209	275	178	492	3A	8450
PKF50TS.150.SIN	5000/600	480-1610	1500	1320	1200 x 150 x 60	209	274	178	498	3A	8520
PKF50TS.155.SIN	5000/600	480-1660	1550	1320	1200 x 150 x 60	209	274	178	504	3A	8570
PKF50TS.175.SIN	5000/600	480-1860	1750	1520	1200 x 150 x 60	209	273	178	528	3A	9210
PKF50TS.185.SIN	5000/600	480-1960	1850	1670	1200 x 150 x 60	209	272	178	540	3A	9310

Advantages

- Excellent forks synchrony
- Easy installation on (triple) forklift masts
- Improved safety thanks to better visibility through the frame
- Easy-to-mount fork pockets

Available on request

- Load backrest
- Other fork sizes
- Model with minimum internal opening of 5 mm
- Model with bolted forks
- Model with connection hoses
- Model with quick connection hoses

Fork positioner with forks with separate sideshifter

PKF-TS.SIN

6000 kg

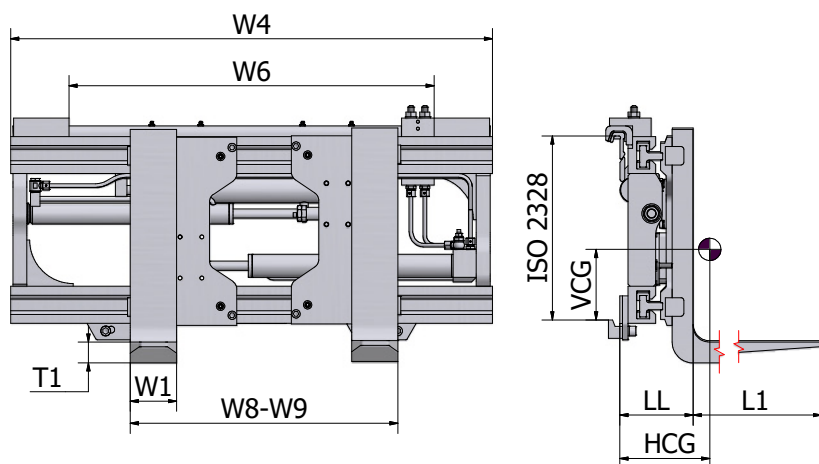

Product info

- W6 – Minimum carriage width
- Technical data without forks
- Maximum advised fork length: 2400 mm
- Linked cylinders for perfect synchronisation
- Total sideshifter stroke: 150 + 150 mm (FEM 4)
- High termination kit yet installed
- Valve block with flow divider
- Upper and lower bushings with grease nipples
- With double rugged T-Bar design
- With low friction nylon bearings



Model	Capacity	W8-W9	W4	W6	Forks L1 x W1 x T1	LL	HCG	VCG	Weight	ISO 2328	RRP
	kg/mm								mm		kg
PKF60TS.135.SIN	6000/600	560-1370	1350	1100	1200 x 150 x 60	223	235	362	588	4A	12150
PKF60TS.145.SIN	6000/600	560-1470	1450	1100	1200 x 150 x 60	223	233	362	601	4A	12150
PKF60TS.160.SIN	6000/600	560-1620	1600	1200	1200 x 150 x 60	223	231	363	619	4A	12280
PKF60TS.165.SIN	6000/600	560-1670	1650	1250	1200 x 150 x 60	223	231	363	626	4A	12330
PKF60TS.170.SIN	6000/600	560-1720	1700	1300	1200 x 150 x 60	223	230	363	632	4A	12370
PKF60TS.180.SIN	6000/600	560-1820	1800	1400	1200 x 150 x 60	223	228	248	645	4A	12520
PKF60TS.185.SIN	6000/600	560-1870	1850	1450	1200 x 150 x 60	220	227	248	651	4A	13070

Advantages

- Excellent forks synchrony
- Easy installation on (triple) forklift masts
- Improved safety thanks to better visibility through the frame
- Easy-to-mount fork pockets

Available on request

- Load backrest
- Other fork sizes
- Model with minimum internal opening of 5 mm
- Model with bolted forks
- Model with connection hoses
- Model with quick connection hoses
- Totale sideshifter stroke 100+100 for FEM 4

PJ-T

2000 kg
2500 kg

Fork positioner with pin-type forks and valve block sideshifter

Product info

- W6 – Minimum carriage width
- Capacity on forks
- Technical data with forks
- Self-lubricating upper sliding bushings
- With integrated sideshifter
- With chrome round upper bar
- With flow divider

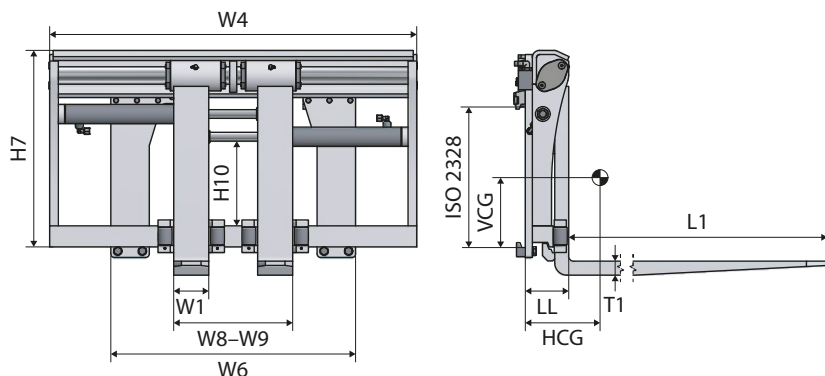

Model	Capacity	W8-W9	W4	W6	Forks L1 x W1 x T1	H10	H7	LL	HCG	VCG	Weight	ISO 2328	RRP
	kg/mm	mm	mm	mm	mm	mm	mm	mm	mm	mm	kg		Euro
PJ20T.090	2000/500	340-780	900	620	1200 x 100 x 40	230	565	124	224	194	217	2A	3430
PJ20T.095	2000/500	340-830	950	620	1200 x 100 x 40	230	565	124	224	194	220	2A	3520
PJ20T.100	2000/500	340-880	1000	620	1200 x 100 x 40	230	565	124	224	194	223	2A	3580
PJ20T.105	2000/500	340-930	1050	720	1200 x 100 x 40	230	565	124	224	194	226	2A	3610
PJ20T.110	2000/500	340-980	1100	720	1200 x 100 x 40	230	565	124	219	197	229	2A	3650
PJ20T.115	2000/500	340-1030	1150	720	1200 x 100 x 40	230	565	124	219	197	232	2A	3730
PJ25T.090	2500/500	340-780	900	620	1200 x 100 x 40	230	565	124	219	197	217	2A	3670
PJ25T.095	2500/500	340-830	950	620	1200 x 100 x 40	230	565	124	219	197	220	2A	3820
PJ25T.100	2500/500	340-880	1000	620	1200 x 100 x 40	230	565	124	219	197	223	2A	3850
PJ25T.105	2500/500	340-930	1050	720	1200 x 100 x 40	230	565	124	219	197	226	2A	3870
PJ25T.110	2500/500	340-980	1100	720	1200 x 100 x 40	230	565	124	215	200	229	2A	3920
PJ25T.115	2500/500	340-1030	1150	720	1200 x 100 x 40	230	565	124	215	200	232	2A	4010
PJ25T.120	2500/500	340-1080	1200	720	1200 x 100 x 40	230	565	124	215	200	236	2A	4120
PJ25T.125	2500/500	340-1130	1250	720	1200 x 100 x 40	230	565	124	215	200	239	2A	4130
PJ25T.135	2500/500	340-1230	1350	720	1200 x 100 x 40	230	565	124	215	200	245	2A	4160
PJ25T.150	2500/500	340-1380	1500	720	1200 x 100 x 40	230	565	124	212	200	260	2A	4440

Attachment not recommended for clamping between forks

Advantages

- Easy to install
- Expertly manufactured
- Superior mechanical strength
- Forks positioning with flow divider

Available on request

- Load backrest
- Class B forks
- Quick-release lower mountings
- Different fork dimensions
- Without integrated sideshift

Fork positioner with pin-type forks and valve block sideshifter

PJ-T

3500 kg
5000 kg

Product info

- W6 – Minimum carriage width
- Capacity on forks
- Technical data with forks
- Self-lubricating upper sliding bushings
- With integrated sideshifter
- With chrome round upper bar
- With flow divider

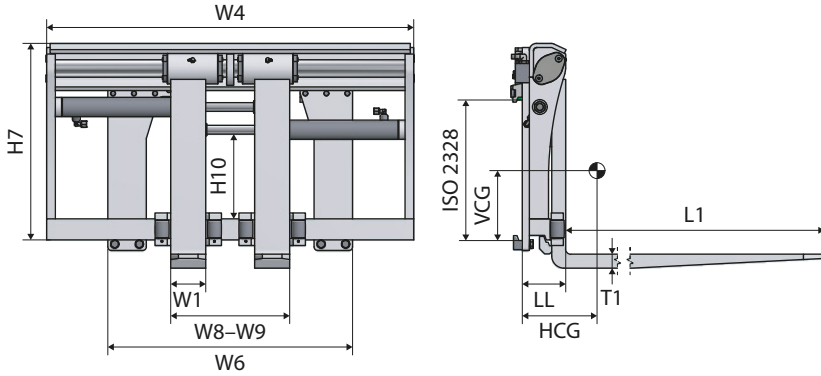

Model	Capacity	W8–W9	W4	W6	Forks L1 x W1 x T1	H10	H7	LL	HCG	VCG	Weight	ISO 2328	RRP
	kg/mm	mm	mm	mm	mm	mm	mm	mm	mm	mm	kg		Euro
PJ35T.110	3500/500	340–980	1100	720	1200 x 120 x 45	315	665	139	233	230	291	3A	4250
PJ35T.115	3500/500	340–1030	1150	720	1200 x 120 x 45	315	665	139	233	230	294	3A	4330
PJ35T.120	3500/500	340–1080	1200	720	1200 x 120 x 45	315	665	139	233	230	298	3A	4470
PJ35T.130	3500/500	340–1180	1300	720	1200 x 120 x 45	315	665	139	229	234	305	3A	4500
PJ35T.150	3500/500	340–1380	1500	720	1200 x 120 x 45	315	665	139	221	241	319	3A	4860
PJ50T.115	5000/500	420–1030	1150	750	1200 x 125 x 50	315	680	151	225	245	388	3A	5430
PJ50T.125	5000/500	420–1130	1250	750	1200 x 125 x 50	315	680	151	220	249	398	3A	5570
PJ50T.140	5000/500	420–1280	1400	750	1200 x 125 x 50	315	680	151	214	255	413	3A	5750
PJ50T.150	5000/500	420–1380	1500	750	1200 x 125 x 50	315	680	151	209	258	423	3A	5900
PJ50T.170	5000/500	420–1580	1700	850	1200 x 125 x 50	315	680	151	203	264	443	3A	6230
PJ55T.140	5000/600	455–1255	1400	900	1200 x 150 x 60	381	810	166	235	267	540	4A	7860
PJ55T.150	5000/600	455–1355	1500	900	1200 x 150 x 60	381	810	166	240	263	550	4A	8050
PJ55T.170	5000/600	455–1555	1700	900	1200 x 150 x 60	381	810	166	245	259	570	4A	9250

Attachment not recommended for clamping between forks

Advantages

- Easy to install
- Expertly manufactured
- Superior mechanical strength
- Forks positioning with flow divider

Available on request

- Load backrest
- Class B forks
- Quick-release lower mountings
- Different fork dimensions
- Without integrated sideshift

PJA-T

2000 kg
2500 kg

Fork positioner with bar-mounted FEM-fork carriers with valve block sideshifter

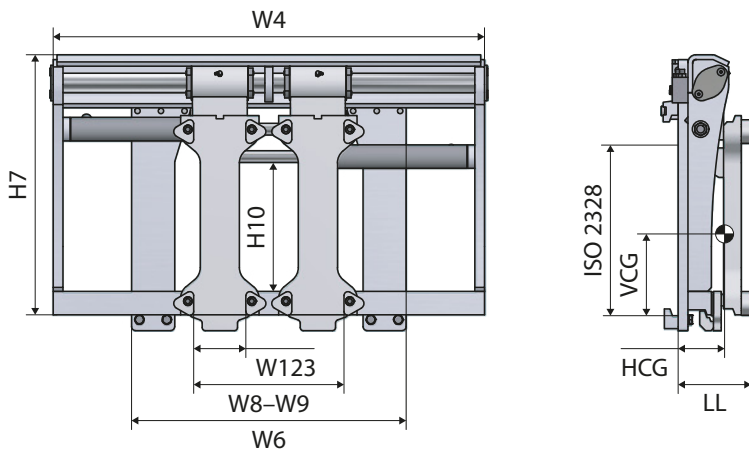

Product info

- W6 – Minimum carriage width
- Technical data without forks
- Standard forks can be easily fitted
- Self-lubricating upper sliding bushings
- With integrated sideshifter
- With chrome round upper bar
- With flow divider



Model	Capacity	W8–W9 mm	W4 mm	W6 mm	Fork width range W123 mm	H10 mm	H7 mm	LL mm	HCG mm	VCG mm	Weight kg	ISO 2328	RRP
	kg/mm												Euro
PJA20T.090P	2000/500	380–790	900	620	100–120–130	230	565	156	67	301	167	2	3750
PJA20T.095P	2000/500	380–840	950	620	100–120–130	230	565	156	67	301	170	2	3830
PJA20T.100P	2000/500	380–890	1000	620	100–120–130	230	565	156	67	301	173	2	3890
PJA20T.105P	2000/500	380–940	1050	720	100–120–130	230	565	156	67	301	176	2	3940
PJA20T.110P	2000/500	380–990	1100	720	100–120–130	230	565	156	62	304	179	2	3980
PJA20T.115P	2000/500	380–1040	1150	720	100–120–130	230	565	156	62	304	182	2	4060
PJA25T.090P	2500/500	380–790	900	620	100–120–130	230	565	156	62	304	167	2	3830
PJA25T.095P	2500/500	380–840	950	620	100–120–130	230	565	156	62	304	170	2	3830
PJA25T.100P	2500/500	380–890	1000	620	100–120–130	230	565	156	62	304	173	2	3990
PJA25T.105P	2500/500	380–940	1050	720	100–120–130	230	565	156	62	304	176	2	4050
PJA25T.110P	2500/500	355–995	1100	720	100–120–130	230	565	156	58	306	179	2	4090
PJA25T.115P	2500/500	380–1040	1150	720	100–120–130	230	565	156	58	306	182	2	4190
PJA25T.125P	2500/500	380–1140	1250	720	100–120–130	230	565	156	58	306	188	2	4320
PJA25T.135P	2500/500	380–1240	1350	720	100–120–130	230	565	156	58	306	194	2	4500
PJA25T.150P	2500/500	380–1390	1500	720	100–120–130	230	565	156	55	306	202	2	4630

Attachment not recommended for clamping between forks

Advantages

- Easy to install
- Expertly manufactured
- Forks positioning with flow divider

Available on request

- Load backrest
- Quick-release lower mountings
- Without Integrated Sideshift

Fork positioner with bar-mounted FEM-fork carriers with valve block sideshifter

PJA-T

3500 kg
5000 kg

Product info

- W6 – Minimum carriage width
- Technical data without forks
- Standard forks can be easily fitted
- Self-lubricating upper sliding bushings
- With integrated sideshifter
- With chrome round upper bar
- With flow divider

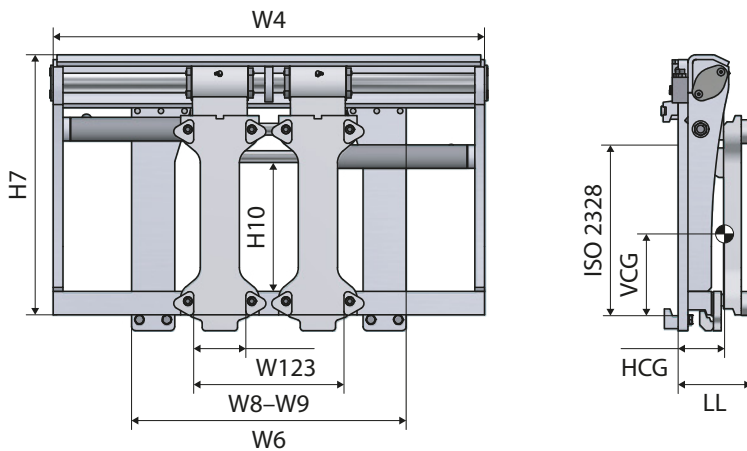

Model	Capacity	W8-W9	W4	W6	Fork width range W123	H10	H7	LL	HCG	VCG	Weight	ISO 2328	RRP
	kg/mm	mm	mm	mm	mm	mm	mm	mm	mm	mm	kg		Euro
PJA35T.110P	3500/500	380-990	1100	720	100-120-130	315	660	161	71	352	210	3	4290
PJA35T.115P	3500/500	380-1040	1150	720	100-120-130	315	660	161	71	351	212	3	4370
PJA35T.125P	3500/500	380-1140	1250	720	100-120-130	315	660	161	71	352	219	3	4540
PJA35T.135P	3500/500	380-1240	1350	720	100-120-130	315	660	161	70	354	226	3	4770
PJA35T.150P	3500/500	380-1390	1500	720	100-120-130	315	660	161	70	355	236	3	4940
PJA50T.115P	5000/500	410-1020	1150	750	120-130-150	255	780	185	80	355	295	3	5310
PJA50T.125P	5000/500	410-1120	1250	750	120-130-150	255	780	185	80	356	305	3	5480
PJA50T.135P	5000/500	410-1220	1350	750	120-130-150	255	780	185	80	357	315	3	5680
PJA50T.150P	5000/500	410-1370	1500	750	120-130-150	255	780	185	80	358	330	3	5830
PJA50T.170P	5000/500	410-1570	1700	850	120-130-150	255	780	185	80	360	350	3	6170
PJA55T.140P	5000/600	460-1260	1400	850	120-130-150	414	806	180	78	405	390	4	8360
PJA55T.150P	5000/600	460-1360	1500	850	120-130-150	414	806	180	78	404	400	4	8620
PJA55T.170P	5000/600	460-560	1700	850	120-130-150	414	806	180	78	403	420	4	9880

Attachment not recommended for clamping between forks

Advantages

- Easy to install
- Expertly manufactured
- Forks positioning with flow divider

Available on request

- Load backrest
- Quick-release lower mountings
- Without Integrated Sideshift

PJI-T

2000 kg
2500 kg

Integrated fork positioner with pin-type forks and valve block sideshifter

Product info

- Technical data with forks
- Capacity on forks
- Technical data without carriage side plates
- Self-lubricating upper sliding bushings
- With integrated sideshifter
- With chrome round upper bar

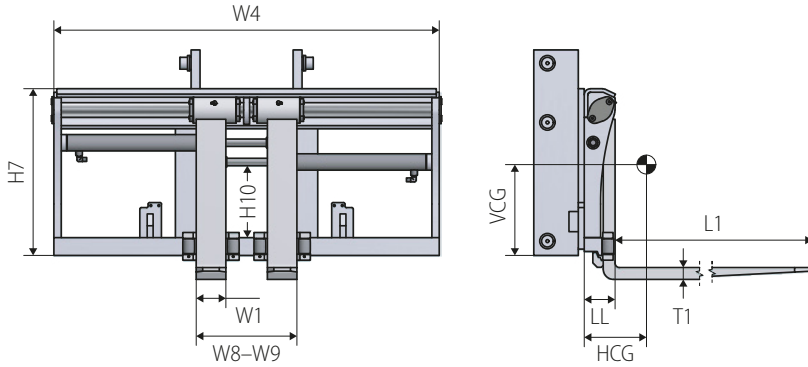

Model	Capacity	W8-W9	W4	Forks L1 x W1 x T1	H10	H7	LL	HCG	VCG	Weight	RRP
	kg/mm	mm	mm	mm	mm	mm	mm	mm	mm	kg	Euro
PJI20T.090	2000/500	340-780	900	1200 x 100 x 40	210	565	104	206	193	204	3960
PJI20T.095	2000/500	340-830	950	1200 x 100 x 40	210	565	104	204	195	207	4060
PJI20T.100	2000/500	340-880	1000	1200 x 100 x 40	210	565	104	202	197	210	4100
PJI20T.105	2000/500	340-930	1050	1200 x 100 x 40	210	565	104	198	200	213	4170
PJI20T.110	2000/500	340-980	1100	1200 x 100 x 40	210	565	104	196	202	216	4230
PJI20T.115	2000/500	340-1030	1150	1200 x 100 x 40	210	565	104	192	204	219	4290
PJI25T.090	2500/500	340-780	900	1200 x 100 x 40	227	565	104	192	198	203	4180
PJI25T.095	2500/500	340-830	950	1200 x 100 x 40	227	565	104	193	199	208	4320
PJI25T.100	2500/500	340-880	1000	1200 x 100 x 40	227	565	104	195	200	211	4350
PJI25T.105	2500/500	340-930	1050	1200 x 100 x 40	227	565	104	197	201	213	4380
PJI25T.110	2500/500	340-980	1100	1200 x 100 x 40	227	565	104	196	202	218	4430
PJI25T.115	2500/500	340-1030	1150	1200 x 100 x 40	227	565	104	193	203	222	4480
PJI25T.125	2500/500	340-1130	1250	1200 x 100 x 40	227	565	104	189	205	228	4620
PJI25T.135	2500/500	340-1230	1350	1200 x 100 x 40	227	565	104	187	208	237	4690
PJI25T.150	2500/500	340-1380	1500	1200 x 100 x 40	227	565	104	180	214	244	4910

Attachments not recommended for clamping between forks. These models are integrated in the mast. Supplied with side plates and roller shafts. Mast engineering drawings required.

Available on request

- Load backrest
- Different fork dimensions

Integrated fork positioner with pin-type forks and valve block sideshifter

PJI-T

3500 kg
5000 kg

Product info

- Technical data with forks
- Capacity on forks
- Technical data without carriage side plates
- Self-lubricating upper sliding bushings
- With integrated sideshifter
- With chrome round upper bar

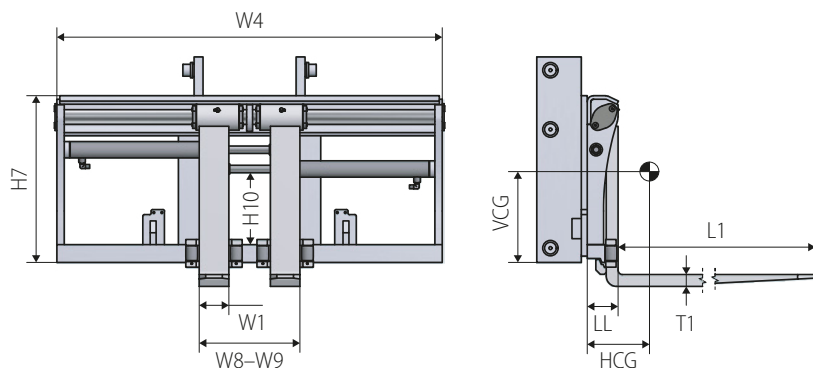

Model	Capacity	W8-W9	W4	Forks L1 x W1 x T1	H10	H7	LL	HCG	VCG	Weight	RRP
	kg/mm	mm	mm	mm	mm	mm	mm	mm	mm	kg	Euro
PJI35T.110	3500/500	340-980	1100	1200 x 120 x 45	383	660	110	217	235	274	5040
PJI35T.115	3500/500	340-1030	1150	1200 x 120 x 45	383	660	110	213	237	281	5100
PJI35T.120	3500/500	340-1080	1200	1200 x 120 x 45	383	660	110	210	239	287	5240
PJI35T.130	3500/500	340-1180	1300	1200 x 120 x 45	383	660	110	208	240	291	5310
PJI35T.150	3500/500	340-1380	1500	1200 x 120 x 45	383	660	110	199	246	306	5540
PJI50T.115	5000/500	420-1030	1150	1200 x 125 x 50	315	680	120	205	245	365	6210
PJI50T.125	5000/500	420-1130	1250	1200 x 125 x 50	315	680	120	200	247	381	6390
PJI50T.140	5000/500	420-1280	1400	1200 x 125 x 50	315	680	120	194	253	393	6530
PJI50T.150	5000/500	420-1380	1500	1200 x 125 x 50	315	680	120	188	255	403	6730
PJI50T.170	5000/500	420-1580	1700	1200 x 125 x 50	315	680	120	183	264	426	7070
PJI55T.140	5000/600	455-1255	1400	1200 x 150 x 60	381	810	145	215	264	523	8020
PJI55T.150	5000/600	455-1355	1500	1200 x 150 x 60	381	810	145	220	260	533	8200
PJI55T.170	5000/600	455-1555	1700	1200 x 150 x 60	381	810	145	225	256	553	9370

Attachments not recommended for clamping between forks. These models are integrated in the mast. Supplied with side plates and roller shafts. Mast engineering drawings required.

Available on request

- Load backrest
- Different fork dimensions

PF

2500 kg
5000 kg

Fork positioner with pin-type forks without sideshifter

Product info

- W6 – Minimum carriage width
- Capacity on forks
- Technical data with forks
- Self-lubricating upper sliding bushings
- With chrome round upper bar
- Without separate sideshifter

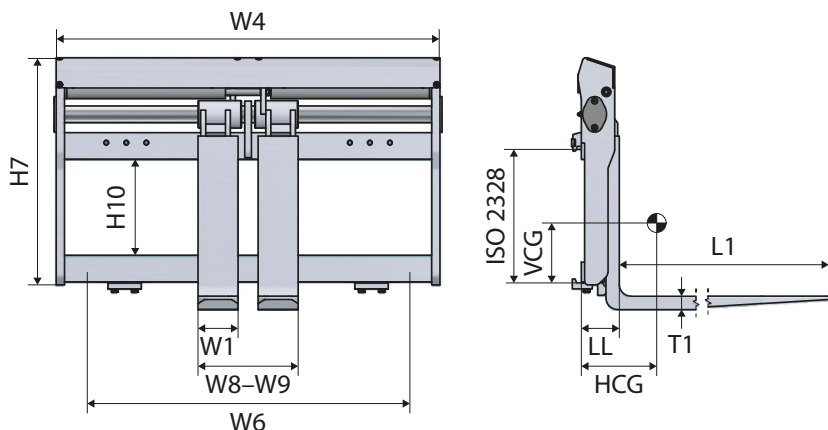

Model	Capacity	W8–W9	W4	W6	Forks L1 x W1 x T1	H10	H7	LL	HCG	VCG	Weight	ISO 2328	RRP
	kg/mm	mm	mm	mm	mm	mm	mm	mm	mm	mm	kg		Euro
PF25.098	2500/500	300–910	980	800	1200 x 120 x 40	290	640	110	249	183	223	2A	3690
PF25.104	2500/500	300–970	1040	800	1200 x 120 x 40	290	640	110	245	186	229	2A	3770
PF25.110	2500/500	300–1030	1100	900	1200 x 120 x 40	290	640	110	242	189	231	2A	3890
PF25.115	2500/500	300–1080	1150	900	1200 x 120 x 40	290	640	110	239	192	234	2A	3980
PF25.125	2500/500	300–1180	1250	1000	1200 x 120 x 40	290	640	110	236	194	241	2A	4070
PF25.130	2500/500	300–1230	1300	1000	1200 x 120 x 40	290	640	110	233	195	244	2A	4180
PF25.150	2500/500	300–1430	1500	1100	1200 x 120 x 40	290	640	110	221	207	257	2A	4270
PF35.110	3500/500	340–1040	1100	900	1200 x 120 x 45	395	750	135	228	253	314	3A	4430
PF35.115	3500/500	340–1090	1150	900	1200 x 120 x 45	395	750	135	225	253	319	3A	4630
PF35.125	3500/500	340–1190	1250	1000	1200 x 120 x 45	395	750	135	223	253	330	3A	4670
PF35.135	3500/500	340–1290	1350	1000	1200 x 120 x 45	395	750	135	222	255	341	3A	4850
PF35.155	3500/500	340–1490	1550	1200	1200 x 120 x 45	395	750	135	220	255	360	3A	5120
PF50.110	5000/500	340–1040	1100	900	1200 x 150 x 50	395	750	140	250	237	370	3A	4670
PF50.115	5000/500	340–1090	1150	900	1200 x 150 x 50	395	750	140	247	238	375	3A	4860
PF50.125	5000/500	340–1190	1250	1000	1200 x 150 x 50	395	750	140	245	240	386	3A	4900
PF50.135	5000/500	340–1290	1350	1000	1200 x 150 x 50	395	750	140	241	242	397	3A	5090
PF50.155	5000/500	340–1490	1550	1200	1200 x 150 x 50	395	750	140	229	244	416	3A	5350
PF50.165	5000/500	340–1590	1650	1200	1200 x 150 x 50	395	750	140	223	245	429	3A	5780

Attachment not recommended for clamping between forks

Available on request

- Class B forks
- Different fork dimensions
- Quick-release lower mountings

Fork positioner with pin-type forks without sideshifter

PF

6000 kg
8000 kg

Product info

- W6 – Minimum carriage width
- Capacity on forks
- Technical data with forks
- Self-lubricating upper sliding bushings
- With chrome round upper bar
- Without separate sideshifter

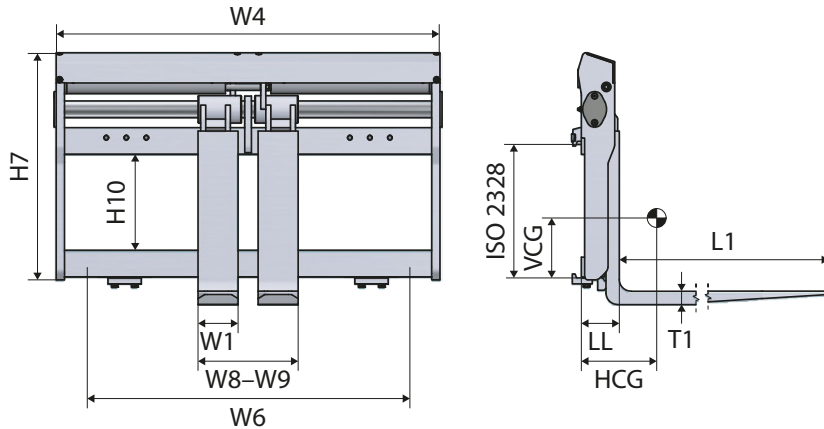

Model	Capacity	W8–W9	W4	W6	Forks L1 x W1 x T1	H10	H7	LL	HCG	VCG	Weight	ISO 2328	RRP
	kg/mm	mm	mm	mm	mm	mm	mm	mm	mm	mm	kg		Euro
PF60.150	6000/600	570–1420	1500	1200	1200 x 150 x 60	300	870	165	180	312	622	4A	8650
PF60.170	6000/600	570–1620	1700	1400	1200 x 150 x 60	300	870	165	175	312	657	4A	8950
PF60.190	6000/600	570–1820	1900	1600	1200 x 150 x 60	300	870	165	170	312	692	4A	9290
PF80.150	8000/600	570–1420	1500	1200	1200 x 150 x 70	300	870	175	175	291	717	4A	9180
PF80.180	8000/600	570–1720	1800	1500	1200 x 150 x 70	300	870	175	170	291	757	4A	9360
PF80.200	8000/600	570–1920	2000	1600	1200 x 150 x 70	300	870	175	165	291	797	4A	9950
PF80.220	8000/600	570–2120	2200	1800	1200 x 150 x 70	300	870	175	160	291	837	4A	10760
PF80.240	8000/600	570–2320	2400	2000	1200 x 150 x 70	300	870	175	155	291	877	4A	11590
PF100.200.5	10000/600	560–1880	2000	1700	1200 x 200 x 70	350	870	276	223	315	1340	5A	On request
PF100.220.5	10000/600	560–2080	2200	1900	1200 x 200 x 70	350	870	276	220	315	1460	5A	On request
PF100.240.5	10000/600	560–2280	2400	2100	1200 x 200 x 70	350	870	276	217	315	1520	5A	On request
PF120.180	12000/600	560–1800	1800	1400	1200 x 200 x 70	350	870	276	213	320	1150	4A	On request
PF120.220	12000/600	560–2200	2200	1800	1200 x 200 x 70	350	870	260	210	320	1270	4A	On request
PF120.240	12000/600	560–2400	2400	2000	1200 x 200 x 70	350	870	260	208	320	1330	4A	On request
PF120.180.1800	8000/900	560–1680	1800	1400	1800 x 200 x 70	350	870	260	328	305	1350	4A	On request
PF120.220.1800	8000/900	560–2080	2200	2000	1800 x 200 x 70	350	870	260	325	305	1510	4A	On request
PF120.240.1800	8000/900	560–2280	2400	2000	1800 x 200 x 70	350	870	260	323	305	1570	4A	On request

Attachment not recommended for clamping between forks

Available on request

- Class B forks
- Different fork dimensions
- Quick-release lower mountings

PF-T

2500 kg
5000 kg

Fork positioner with pin-type forks with separate sideshifter

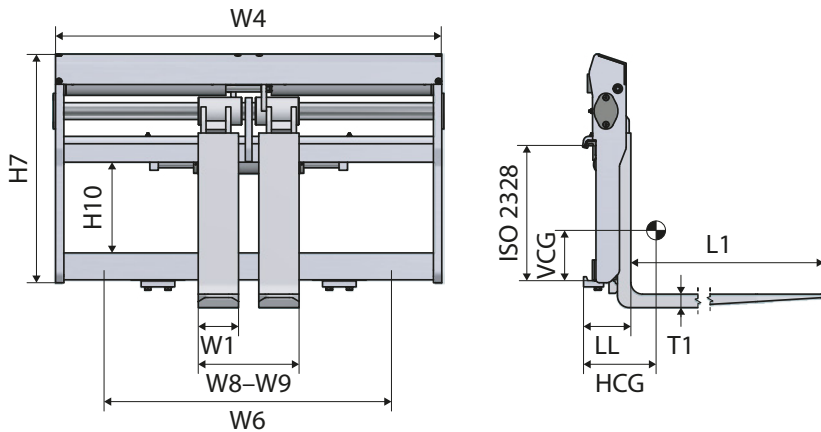

Product info

- W6 – Minimum carriage width
- Capacity on forks
- Technical data with forks
- Self-lubricating upper sliding bushings
- With chrome round upper bar
- With separate sideshifter
- Total sideshifter stroke: 100 + 100 mm (FEM 2–FEM 3)



Model	Capacity	W8–W9	W4	W6	Forks L1 x W1 x T1	H10	H7	LL	HCG	VCG	Weight	ISO 2328	RRP
	kg/mm	mm	mm	mm	mm	mm	mm	mm	mm	mm	kg		Euro
PF25T.098	2500/500	300–910	980	800	1200 x 120 x 40	240	640	115	250	190	227	2A	4240
PF25T.104	2500/500	300–970	1040	800	1200 x 120 x 40	240	640	115	245	192	231	2A	4340
PF25T.110	2500/500	300–1030	1100	900	1200 x 120 x 40	240	640	115	240	194	235	2A	4430
PF25T.115	2500/500	300–1080	1150	900	1200 x 120 x 40	240	640	115	237	196	239	2A	4470
PF25T.125	2500/500	300–1180	1250	1000	1200 x 120 x 40	240	640	115	232	198	246	2A	4570
PF25T.130	2500/500	300–1230	1300	1000	1200 x 120 x 40	240	640	115	229	201	249	2A	4670
PF25T.150	2500/500	300–1430	1500	1100	1200 x 120 x 40	240	640	115	225	202	266	2A	4730
PF35T.110	3500/500	340–1040	1100	900	1200 x 120 x 45	310	750	137	218	251	320	3A	5010
PF35T.115	3500/500	340–1090	1150	900	1200 x 120 x 45	310	750	137	215	251	325	3A	5180
PF35T.125	3500/500	340–1190	1250	1000	1200 x 120 x 45	310	750	137	213	251	336	3A	5280
PF35T.135	3500/500	340–1290	1350	1000	1200 x 120 x 45	310	750	137	211	253	347	3A	5460
PF35T.155	3500/500	340–1490	1550	1200	1200 x 120 x 45	310	750	137	209	253	366	3A	5920
PF50T.110	5000/500	340–1040	1100	900	1200 x 150 x 50	310	750	142	244	235	376	3A	5240
PF50T.115	5000/500	340–1090	1150	900	1200 x 150 x 50	310	750	142	241	236	381	3A	5420
PF50T.125	5000/500	340–1190	1250	1000	1200 x 150 x 50	310	750	142	239	238	392	3A	5520
PF50T.135	5000/500	340–1290	1350	1000	1200 x 150 x 50	310	750	142	237	240	403	3A	5700
PF50T.155	5000/500	340–1490	1550	1200	1200 x 150 x 50	310	750	142	224	242	422	3A	6160
PF50T.165	5000/500	340–1590	1650	1200	1200 x 150 x 50	310	750	142	218	243	432	3A	6530

Attachment not recommended for clamping between forks

Available on request

- Class B forks
- Different fork dimensions
- Quick-release lower mountings

Fork positioner with pin-type forks with separate sideshifter

PF-T

6000 kg
8000 kg

Product info

- W6 – Minimum carriage width
- Capacity on forks
- Technical data with forks
- Self-lubricating upper sliding bushings
- With chrome round upper bar
- With separate sideshifter
- Total sideshifter stroke: 150 + 150 mm (FEM 4)

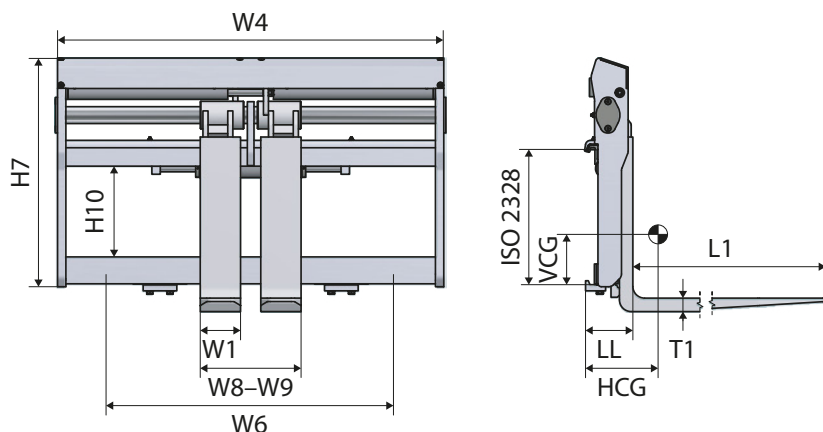

Model	Capacity	W8-W9	W4	W6	Forks L1 x W1 x T1	H10	H7	LL	HCG	VCG	Weight	ISO 2328	RRP
	kg/mm	mm	mm	mm	mm	mm	mm	mm	mm	mm	kg		Euro
PF60T.150	6000/600	570-1420	1500	1200	1200 x 150 x 60	300	870	165	180	324	649	4A	9230
PF60T.170	6000/600	570-1620	1700	1400	1200 x 150 x 60	300	870	165	175	326	690	4A	9530
PF60T.190	6000/600	570-1820	1900	1600	1200 x 150 x 60	300	870	165	170	328	729	4A	9890
PF80T.150	8000/600	570-1420	1500	1200	1200 x 150 x 70	300	870	165	210	318	732	4A	9580
PF80T.180	8000/600	570-1720	1800	1500	1200 x 150 x 70	300	870	165	205	320	772	4A	9760
PF80T.200	8000/600	570-1920	2000	1600	1200 x 150 x 70	300	870	165	200	322	812	4A	10270
PF80T.220	8000/600	570-2120	2200	1800	1200 x 150 x 70	300	870	165	195	325	852	4A	10820
PF80T.240	8000/600	570-2320	2400	2000	1200 x 150 x 70	300	870	165	190	327	892	4A	11650
PF100T.200.5	10000/600	560-1880	2000	1700	1200 x 200 x 70	350	870	276	223	315	1360	5A	On request
PF100T.220.5	10000/600	560-2080	2200	1900	1200 x 200 x 70	350	870	276	220	314	1480	5A	On request
PF100T.240.5	10000/600	560-2280	2400	2100	1200 x 200 x 70	350	870	276	217	313	1540	5A	On request
PF120T.180	12000/600	560-1880	1800	1400	1200 x 200 x 70	350	870	260	213	320	1170	4A	On request
PF120T.220	12000/600	560-2080	2200	1800	1200 x 200 x 70	350	870	260	210	325	1290	4A	On request
PF120T.240	12000/600	560-2280	2400	2000	1200 x 200 x 70	350	870	260	208	320	1350	4A	On request
PF120T.180.1800	8000/900	560-1680	1800	1400	1800 x 200 x 70	350	870	260	328	305	1370	4A	On request
PF120T.220.1800	8000/900	560-2080	2000	1800	1800 x 200 x 70	350	870	260	325	305	1530	4A	On request
PF120T.240.1800	8000/900	560-2280	2220	2000	1800 x 200 x 70	350	870	260	323	305	1590	4A	On request

Attachment not recommended for clamping between forks

Available on request

- Class B forks
- Different fork dimensions
- Quick-release lower mountings

PFA

2500 kg
5000 kg

Heavy-duty fork positioner with bar-mounted FEM fork carriers without sideshifter

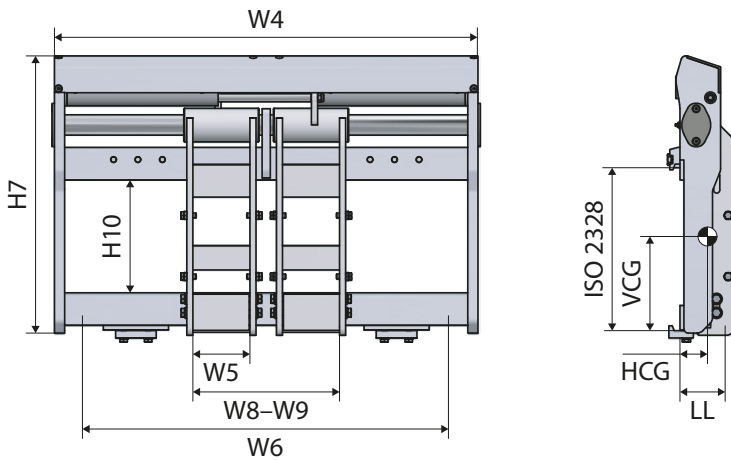

Product info

- W6 – Minimum carriage width
- W5 – Fork adapter width
- Technical data without forks
- Maximum advised fork length: 1800 mm (FEM 2–FEM 3)
- Self-lubricating upper sliding bushings
- With chrome round upper bar
- Without separate sideshifter
- Standard forks can be easily fitted



Model	Capacity	W8–W9 mm	W4 mm	W6 mm	W5 mm	H10 mm	H7 mm	LL mm	HCG mm	VCG mm	Weight kg	ISO 2328	RRP
	kg/mm												Euro
PFA25.098	2500/500	360–870	980	800	130*	290	640	104	51	332	135	2	3540
PFA25.104	2500/500	360–930	1040	800	130*	290	640	104	51	333	140	2	3650
PFA25.110	2500/500	360–990	1100	800	130*	290	640	104	51	334	143	2	3720
★ PFA25.115	2500/500	360–1040	1150	800	130*	290	640	104	50	335	146	2	3840
PFA25.125	2500/500	360–1140	1250	1000	130*	290	640	104	50	336	152	2	3920
PFA25.130	2500/500	360–1190	1300	1000	130*	290	640	104	50	337	155	2	4020
PFA25.150	2500/500	360–1390	1500	1100	130*	290	640	104	50	341	167	2	4120
PFA50.110	5000/500	400–980	1100	900	150**	340	750	133	60	378	223	3	4480
PFA50.115	5000/500	400–1030	1150	900	150**	340	750	133	60	378	228	3	4680
PFA50.125	5000/500	400–1130	1250	1000	150**	340	750	133	60	380	238	3	4700
PFA50.135	5000/500	400–1230	1350	1000	150**	340	750	133	59	381	249	3	4890
PFA50.155	5000/500	400–1430	1550	1100	150**	340	750	133	58	383	270	3	5140
PFA50.165	5000/500	400–1530	1650	1200	150**	340	750	133	58	384	282	3	5550

★ Suggested selection

* Pocket accepts fork widths from 100 mm to 130 mm

** Pocket accepts fork widths from 150 mm to 200 mm

Attachment not recommended for clamping between forks

Heavy-duty fork positioner with bar-mounted FEM fork carriers without sideshifter

PFA

6000 kg
12000 kg

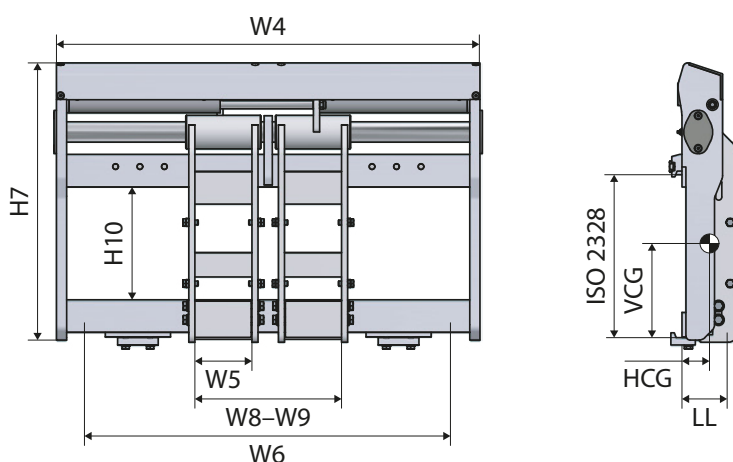

Product info

- W6 – Minimum carriage width
- W5 – Fork adapter width
- Technical data without forks
- Maximum advised fork length: 2600 mm (FEM 4)
- Self-lubricating upper sliding bushes
- With chrome round upper bar
- Without separate sideshifter
- Standard forks can be easily fitted



Model	Capacity	W8–W9 mm	W4 mm	W6 mm	W5 mm	H10 mm	H7 mm	LL mm	HCG mm	VCG mm	Weight kg	ISO 2328	RRP
	kg/mm												Euro
PFA60.120	6000/600	515–1065	1200	1100	200**	300	870	209	97	444	460	4	8300
PFA60.135	6000/600	515–1215	1350	1100	200**	300	870	209	97	444	480	4	8330
PFA60.150	6000/600	515–1365	1500	1200	200**	300	870	209	97	444	510	4	8360
PFA60.170	6000/600	515–1565	1700	1400	200**	300	870	209	95	444	550	4	9050
PFA60.190	6000/600	515–1765	1900	1600	200**	300	870	209	95	444	590	4	9720
PFA80.150	8000/600	515–1365	1500	1200	200**	300	870	209	91	417	610	4	8800
PFA80.180	8000/600	515–1665	1800	1500	200**	300	870	209	91	417	650	4	9010
PFA80.200	8000/600	515–1865	2000	1600	200**	300	870	209	91	417	690	4	9550
PFA80.220	8000/600	515–2065	2200	1800	200**	300	870	209	91	417	730	4	10360
PFA80.240	8000/600	515–2265	2400	2000	200**	300	870	209	91	417	770	4	11200
PFA100.200.5	10000/600	560–1800	2000	1600	200**	300	870	280	122	489	1025	5	17450
PFA100.220.5	10000/600	560–2000	2200	1800	200**	300	870	280	119	489	1065	5	18020
PFA100.240.5	10000/600	560–2200	2400	2000	200**	300	870	280	117	489	1105	5	18600
PFA120.180	12000/600	560–1600	1800	1400	200**	300	870	260	120	440	930	4	14250
PFA120.220	12000/600	560–2000	2200	1800	200**	300	870	260	120	440	1050	4	14830
PFA120.240	12000/600	560–2200	2400	2000	200**	300	870	260	120	440	1090	4	15720

** Pocket accepts fork widths from 150 mm to 200 mm
Attachment not recommended for clamping between forks

PFA-T

2500 kg
5000 kg

Heavy-duty fork positioner with bar-mounted FEM fork carriers with separate sideshifter

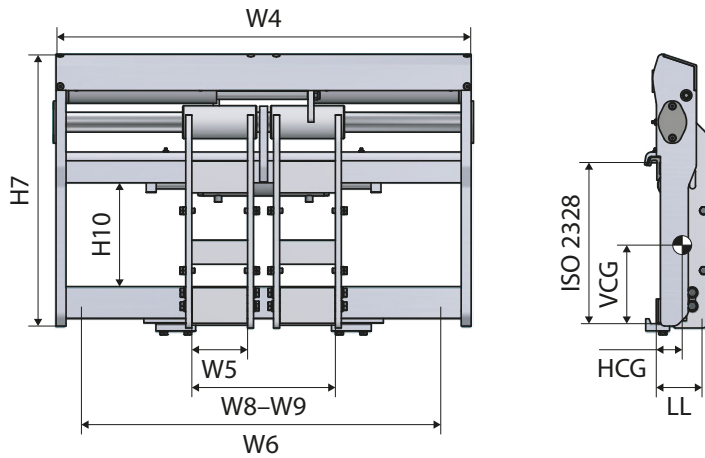

Product info

- W6 – Minimum carriage width
- W5 – Fork adapter width
- Technical data without forks
- Standard forks can be easily fitted
- Maximum advised fork length: 1800 mm (FEM 2–FEM 3)
- Self-lubricating upper sliding bushings
- With chrome round upper bar
- With separate sideshifter
- Total sideshifter stroke: 100 + 100 mm (FEM 2–FEM 3)



Model	Capacity	W8–W9 mm	W4 mm	W6 mm	W5 mm	H10 mm	H7 mm	LL mm	HCG mm	VCG mm	Weight kg	ISO 2328	RRP
	kg/mm												Euro
PFA25T.098	2500/500	360–870	980	800	130*	240	640	104	54	336	141	2	4220
★ PFA25T.104	2500/500	360–930	1040	800	130*	240	640	104	54	336	144	2	4310
PFA25T.110	2500/500	360–990	1100	900	130*	240	640	104	54	336	147	2	4390
★ PFA25T.115	2500/500	360–1040	1150	900	130*	240	640	104	54	336	151	2	4440
PFA25T.125	2500/500	360–1140	1250	1000	130*	240	640	104	54	338	157	2	4540
PFA25T.130	2500/500	360–1190	1300	1000	130*	240	640	104	54	338	160	2	4620
PFA25T.150	2500/500	360–1390	1500	1100	130*	240	640	104	54	338	175	2	4700
PFA50T.110	5000/500	400–980	1100	900	150**	310	750	135	63	378	230	3	5190
PFA50T.115	5000/500	400–1030	1150	900	150**	310	750	135	63	378	235	3	5370
★ PFA50T.125	5000/500	400–1130	1250	1000	150**	310	750	135	63	381	245	3	5480
PFA50T.135	5000/500	400–1230	1350	1000	150**	310	750	135	61	383	252	3	5640
PFA50T.155	5000/500	400–1430	1550	1200	150**	310	750	135	61	384	275	3	6090
PFA50T.165	5000/500	400–1530	1650	1200	150**	310	750	135	60	384	292	3	6450

★ Suggested selection

* Pocket accepts fork widths from 100 mm to 130 mm

** Pocket accepts fork widths from 150 mm to 200 mm

Attachment not recommended for clamping between forks

Heavy-duty fork positioner with bar-mounted FEM fork carriers with separate sideshifter

PFA-T

6000 kg
12000 kg

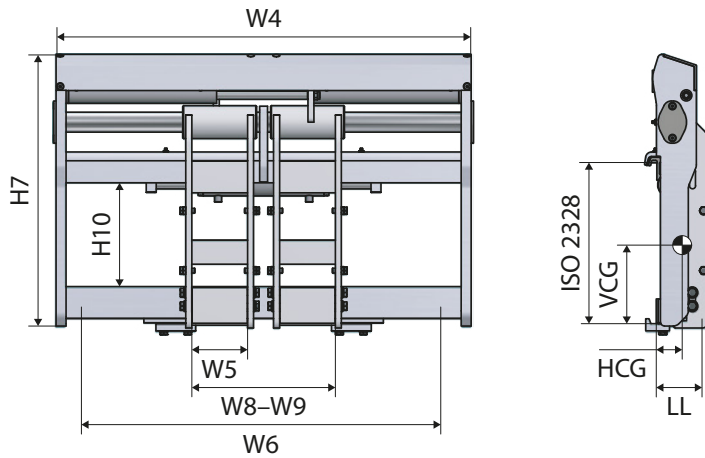

Product info

- W6 – Minimum carriage width
- W5 – Fork adapter width
- Technical data without forks
- Standard forks can be easily fitted
- Maximum advised fork length: 2600 mm (FEM 4)
- Self-lubricating upper sliding bushings
- With chrome round upper bar
- With separate sideshifter
- Total sideshifter stroke: 150 + 150 mm (FEM 4)



Model	Capacity	W8-W9 mm	W4 mm	W6 mm	W5 mm	H10 mm	H7 mm	LL mm	HCG mm	VCG mm	Weight kg	ISO 2328	RRP
	kg/mm												Euro
PFA60T.120	6000/600	515-1065	1200	1100	200**	300	870	210	95	420	504	4	9080
PFA60T.135	6000/600	515-1215	1350	1100	200**	300	870	210	95	427	536	4	9110
PFA60T.150	6000/600	515-1365	1500	1200	200**	300	870	210	97	440	560	4	9160
PFA60T.170	6000/600	515-1565	1700	1400	200**	300	870	210	97	442	600	4	9450
PFA60T.190	6000/600	515-1765	1900	1600	200**	300	870	210	97	445	644	4	9790
PFA80T.150	8000/600	515-1365	1500	1200	200**	300	870	211	97	425	600	4	9470
★ PFA80T.180	8000/600	515-1665	1800	1500	200**	300	870	211	95	430	669	4	9690
PFA80T.200	8000/600	515-1865	2000	1700	200**	300	870	211	94	432	718	4	10180
★ PFA80T.220	8000/600	515-2065	2200	1900	200**	300	870	211	93	432	756	4	10730
PFA80T.240	8000/600	515-2265	2400	2100	200**	300	870	211	92	434	806	4	11560
PFA100T.200.5	10000/600	560-1800	2000	1400	200**	300	870	280	130	487	1125	5	20990
PFA100T.220.5	10000/600	560-2000	2200	1800	200**	300	870	280	130	487	1165	5	21990
PFA100T.240.5	10000/600	560-2200	2400	2000	200**	300	870	280	130	487	1205	5	22940
PFA120T.180	12000/600	560-1600	1800	1400	200**	300	870	260	119	438	1030	4	18790
PFA120T.220	12000/600	560-2000	2200	1800	200**	300	870	260	119	438	1150	4	18970
PFA120T.240	12000/600	560-2200	2400	2000	200**	300	870	260	119	438	1190	4	19890

★ Suggested selection

** Pocket accepts fork widths from 150 mm to 200 mm

Attachment not recommended for clamping between forks

PR & PRI

10000 kg
12000 kg

Integrated high-capacity fork positioner with welded forks

Product info

- W6 – Minimum carriage width
- Technical data with forks
- Welded forks
- Capacity on forks
- Fork positioning with rollers
- Without sideshifter
- Technical data without carriage side plates

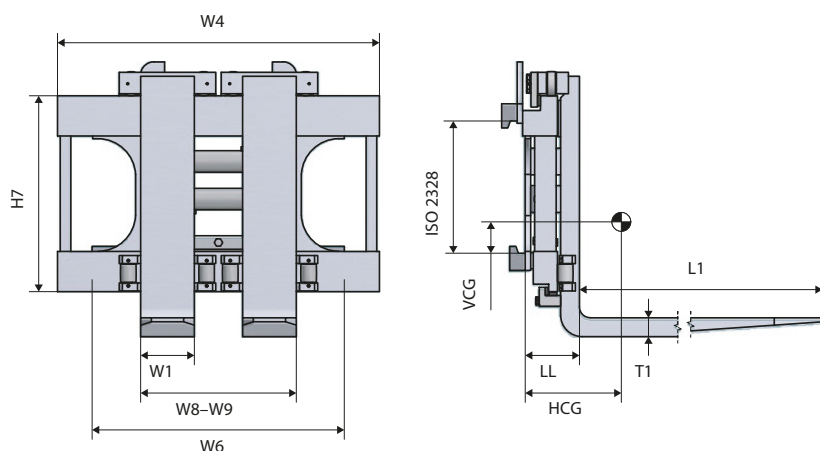

Model	Capacity	W8–W9	W4	W6	Forks L1 x W1 x T1	H7	LL	HCG	VCG	Weight	ISO 2328	RRP
	kg/mm											mm
Model for ISO2328 carriage												
PR100.200	10000/600	580–1800	2000	1700	1600 x 200 x 70	730	197	225	520	1285	4A	18980
PR100.220	10000/600	580–2000	2200	1800	1600 x 200 x 70	730	197	218	535	1320	4A	19820
PR100.240	10000/600	580–2200	2400	1800	1600 x 200 x 70	730	197	208	556	1365	4A	20250
PR120.200	12000/600	580–1800	2000	1700	1600 x 200 x 70	730	197	220	507	1380	4A	23040
PR120.220	12000/600	580–2000	2200	1800	1600 x 200 x 70	730	197	214	523	1415	4A	23040
PR120.240	12000/600	580–2200	2400	1800	1600 x 200 x 70	730	197	204	538	1460	4A	23740
Integrated model*												
PR100.200	10000/600	580–1800	2000	1700	1600 x 200 x 70	730	197	225	520	1285	INTEGRATED*	19680
PR100.220	10000/600	580–2000	2200	1800	1600 x 200 x 70	730	197	218	535	1320	INTEGRATED*	20520
PR100.240	10000/600	580–2200	2400	1800	1600 x 200 x 70	730	197	208	556	1365	INTEGRATED*	20940
PR120.200	12000/600	580–1800	2000	1700	1600 x 200 x 70	730	197	220	507	1380	INTEGRATED*	22780
PR120.220	12000/600	580–2000	2200	1800	1600 x 200 x 70	730	197	214	523	1415	INTEGRATED*	23740
PR120.240	12000/600	580–2200	2400	1800	1600 x 200 x 70	730	197	204	538	1460	INTEGRATED*	24440

Attachments not recommended for clamping between forks.

These models are integrated in the mast. Supplied with side plates and roller shafts. Mast engineering drawings required.

Options

	RRP
	Euro
2 hydraulic functions - valve block sideshift	631

Available on request

- Class B forks
- Different fork dimensions

High-capacity fork positioner with FEM fork carriers without sideshifter

PRA

10000 kg
12000 kg

Product info

- W6 – Minimum carriage width
- W5 – Fork adapter width
- Technical data without forks
- Without sideshifter
- FEM fork carriers with rollers
- Standard forks can be easily fitted

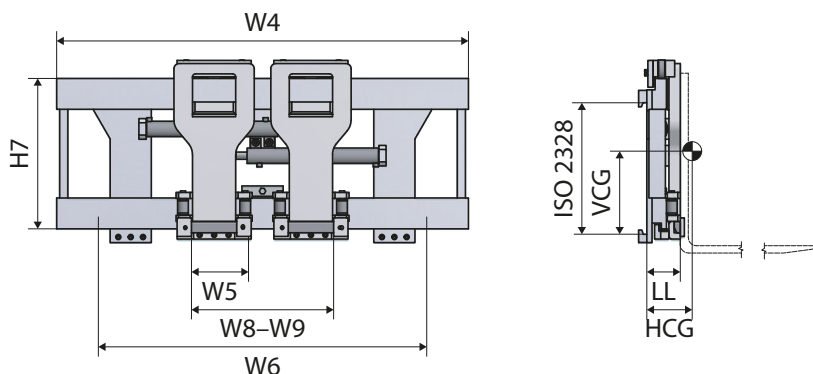

Model	Capacity	W8–W9 mm	W4 mm	W6 mm	W5 mm	H7 mm	LL mm	HCG mm	VCG mm	Weight kg	ISO 2328	RRP
	kg/mm											Euro
PRA100.200	10000/600	630–1820	2000	1700	200	730	162	75	418	810	4	19680
PRA100.220	10000/600	630–2020	2200	1800	200	730	162	74	410	880	4	20520
PRA100.240	10000/600	630–2220	2400	1800	200	730	162	73	403	950	4	20940
PRA120.200	12000/600	630–1820	2000	1700	200	730	172	83	420	855	4	22770
PRA120.220	12000/600	630–2020	2200	1800	200	730	172	82	414	925	4	23740
PRA120.240	12000/600	630–2220	2400	1800	200	730	172	81	408	995	4	24440

Attachment not recommended for clamping between forks

Options

	RRP
	Euro
2 hydraulic functions - valve block sideshift	631

WF

1600 kg
3500 kg

Wide-opening fork positioner with welded forks

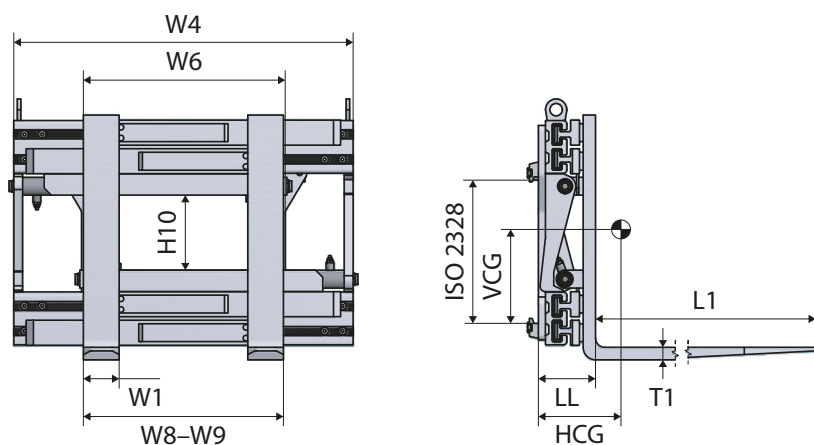

Product info

- W6 – Minimum carriage width
- Technical data with forks
- Welded forks
- Capacity on forks
- Without sidershifter
- Valve block with flow divider



Model	Capacity	W8–W9	W4	W6	Forks L1 x W1 x T1	H10	LL	HCG	VCG	Weight	ISO 2328	RRP
	kg/mm											mm
WF16-A0-12	1600/500	560–1740	950	750	1200 x 100 x 35	210	180	190	195	327	2A	6723
WF16-B0-12	1600/500	560–1840	1050	750	1200 x 100 x 35	210	180	186	199	340	2A	6940
WF20-A0-12	2000/500	560–1740	950	750	1200 x 100 x 40	210	185	197	195	330	2A	7022
WF20-B0-12	2000/500	560–1840	1050	750	1200 x 100 x 40	210	185	197	195	342	2A	7225
WF20-C0-12	2000/500	560–1940	1150	750	1200 x 100 x 40	210	185	197	195	355	2A	7510
WF23-A0-12	2300/500	560–1740	950	750	1200 x 100 x 40	210	185	197	195	333	2A	7300
WF23-B0-12	2300/500	560–1840	1050	750	1200 x 100 x 40	210	185	197	195	345	2A	7490
WF23-C0-12	2300/500	560–1940	1150	750	1200 x 100 x 40	210	185	197	195	358	2A	7815
WF30-A0-12	3000/500	560–1840	1050	800	1200 x 120 x 45	285	190	220	219	400	3A	7547
WF30-B0-12	3000/500	560–1940	1150	900	1200 x 120 x 45	285	190	214	223	406	3A	7777
WF30-C0-12	3000/500	560–2100	1320	900	1200 x 120 x 45	282	190	209	226	412	3A	8743
WF35-A0-12	3500/500	560–1840	1050	800	1200 x 120 x 50	285	195	220	219	450	3A	8785
WF35-B0-12	3500/500	560–1940	1150	900	1200 x 120 x 50	285	195	214	223	456	3A	9015
WF35-C0-12	3500/500	560–2100	1320	900	1200 x 120 x 50	282	195	209	226	462	3A	10074

Attachments not recommended for clamping between forks

Options

	RRP
	Euro
2 hydraulic functions – independent control forks	630
Separate sidershifter: 100 + 100 mm for ISO/FEM 2	1330
Separate sidershifter: 100 + 100 mm for ISO/FEM 3	1800
Separate sidershifter: 100 + 100 mm for ISO/FEM 4	2140
2 hydraulic functions – independent arm control	965
Quick-release lower mountings, class 2 or class 3	605
Quick-release lower mountings, class 4	810

Available on request

- Class B forks
- Bolted forks
- Different fork dimensions
- Other opening range

Wide-opening fork positioner with welded forks

WF

4000 kg
9000 kg

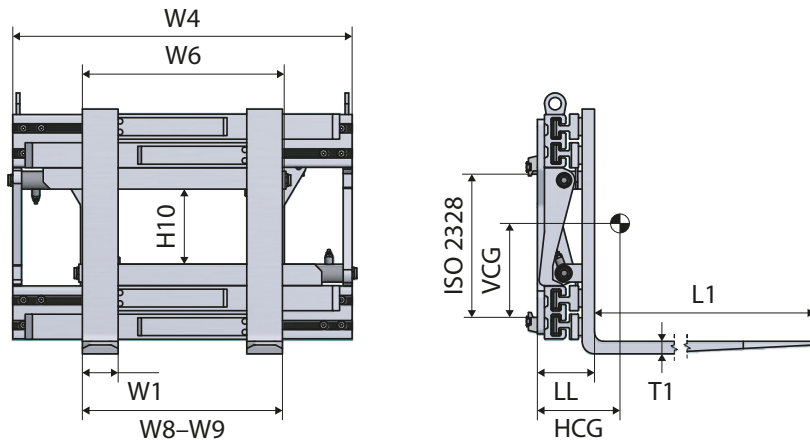

Product info

- W6 – Minimum carriage width
- Technical data with forks
- Welded forks
- Capacity on forks
- Without sideshifter
- Valve block with flow divider



Model	Capacity	W8–W9	W4	W6	Forks L1 x W1 x T1	H10	LL	HCG	VCG	Weight	ISO 2328	RRP
	kg/mm									mm		kg
WF40-A0-12	4000/500	560–1940	1150	900	1200 x 120 x 50	240	225	206	254	572	3A	9891
WF40-B0-12	4000/500	560–2100	1320	1000	1200 x 120 x 50	240	225	199	258	613	3A	10158
WF40-C0-12	4000/500	560–2400	1600	1050	1200 x 120 x 50	240	225	190	262	658	3A	10770
WF45-A0-12	4500/500	560–1940	1150	900	1200 x 150 x 50	240	225	226	244	617	3A	11698
WF45-B0-12	4500/500	560–2100	1320	1000	1200 x 150 x 50	240	225	218	248	655	3A	12036
WF45-C0-12	4500/500	560–2400	1600	1050	1200 x 150 x 50	240	225	209	252	700	3A	12755
WF55-A0-12	5500/600	560–2100	1320	1000	1200 x 150 x 60	330	225	186	248	677	4A	14448
WF55-B0-12	5500/600	560–2400	1600	1050	1200 x 150 x 60	330	225	176	248	707	4A	16270
WF65-A0-12	6500/600	560–2400	1600	1050	1200 x 150 x 60	330	235	181	248	815	4A	18647
WF65-B0-12	6500/600	560–2600	1800	1200	1200 x 150 x 60	330	235	172	248	840	4A	19784
WF80-A0-12	8000/600	660–2390	1800	1250	1200 x 150 x 70	250	290	205	252	1590	4A	On request
WF90-A0-12	9000/600	660–2590	2000	1350	1200 x 200 x 70	245	295	195	254	1680	4A	On request

Attachments not recommended for clamping between forks

Options

	RRP
	Euro
2 hydraulic functions – independent control forks	630
Separate sideshifter: 100 + 100 mm for ISO/FEM 2	1330
Separate sideshifter: 100 + 100 mm for ISO/FEM 3	1800
Separate sideshifter: 100 + 100 mm for ISO/FEM 4	2140
2 hydraulic functions – independent arm control	965
Quick-release lower mountings, class 2 or class 3	605
Quick-release lower mountings, class 4	810

Available on request

- Class B forks
- Bolted forks
- Different fork dimensions
- Other opening range

WA

1600 kg
5000 kg

Wide-opening fork positioner with FEM fork carriers

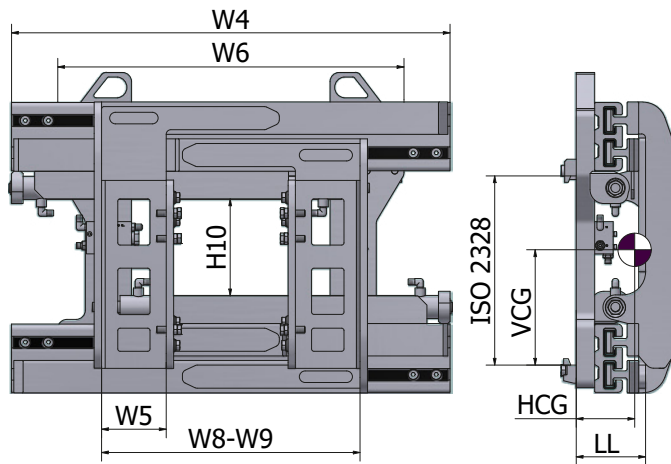

Product info

- W6 – Minimum carriage width
- W5 – Fork adapter width
- Maximum advised fork length: 1600 mm (FEM 2 – FEM 3)
- Without sideshifter
- Standard forks can be easily fitted
- Valve block with flow divider



Model	Capacity	W8–W9 mm	W4 mm	W6 mm	W5 mm	H10 mm	LL mm	HCG mm	VCG mm	Weight kg	ISO 2328	RRP
	kg/mm											Euro
WA16-AO	1600/500	560–1740	950	750	130	210	190	87	250	270	2	5270
WA16-BO	1600/500	560–1840	1050	750	130	210	190	87	247	277	2	5430
WA16-CO	1600/500	560–1940	1150	750	130	210	190	86	244	291	2	5700
WA20-AO	2000/500	560–1740	950	750	130	210	190	87	253	273	2	5430
WA20-BO	2000/500	560–1840	1050	750	130	210	190	87	250	280	2	5580
WA20-CO	2000/500	560–1940	1150	750	130	210	190	86	247	294	2	5850
★ WA23-AO	2300/500	560–1740	950	750	130	210	190	87	256	276	2	5940
★ WA23-BO	2300/500	560–1840	1050	750	130	210	190	87	253	283	2	6080
WA23-CO	2300/500	560–1940	1150	750	130	210	190	86	250	297	2	6270
★ WA30-AO	3000/500	560–1840	1050	800	150	285	198	92	295	324	3	6340
★ WA30-BO	3000/500	560–1940	1150	900	150	285	198	93	290	335	3	6570
★ WA30-CO	3000/500	560–2100	1320	900	150	285	198	93	290	357	3	6850
WA35-AO	3500/500	560–1840	1050	800	150	285	200	92	295	337	3	6606
WA35-BO	3500/500	560–1940	1150	900	150	285	200	93	290	345	3	6960
WA35-CO	3500/500	560–2100	1320	900	150	285	200	93	290	369	3	7390
WA40-AO	4000/500	550–1930	1150	900	150	240	234	99	310	454	3	7152
WA40-BO	4000/500	560–2100	1320	1000	150	240	234	99	311	486	3	7589
WA40-CO	4000/500	560–2400	1600	1050	150	240	234	99	311	550	3	8354
WA45-AO	4500/500	560–1940	1150	900	150	240	234	99	310	458	3	7698
WA45-BO	4500/500	560–2100	1320	1000	150	240	234	99	311	490	3	8135
WA45-CO	4500/500	560–2400	1600	1050	150	240	234	99	311	554	3	8900
WA50-AO	5000/500	560–1940	1150	900	150	240	234	99	310	462	3	9453
WA50-BO	5000/500	560–2100	1320	1000	150	240	234	99	311	494	3	9913
WA50-CO	5000/500	560–2400	1600	1050	150	240	234	99	311	558	3	10718

★ Suggested selection

Attachment not recommended for clamping between forks

Wide-opening fork positioner with FEM fork carriers

WA

5500 kg
9000 kg

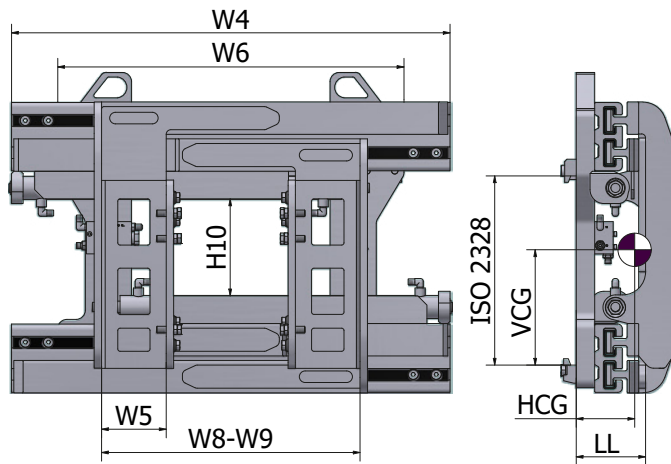

Product info

- W6 – Minimum carriage width
- W5 – Fork adapter width
- Maximum advised fork length: 2000 mm (FEM 4)
- Without sideshifter
- Standard forks can be easily fitted
- Valve block with flow divider



Model	Capacity	W8–W9 mm	W4 mm	W6 mm	W5 mm	H10 mm	LL mm	HCG mm	VCG mm	Weight kg	ISO 2328	RRP
	kg/mm											Euro
WA55-A0	5500/600	560–2100	1320	1000	200	242	250	115	288	600	4	11607
WA55-B0	5500/600	560–2400	1600	1050	200	242	250	111	279	685	4	13172
WA65-A0	6500/600	560–2380	1600	1050	200	330	250	109	291	783	4	14947
WA65-B0	6500/600	560–2580	1800	1200	200	330	250	107	290	835	4	15637
WA80-A0	8000/600	660–2390	1800	1250	200	250	275	135	290	920	4	On request
WA90-A0	9000/600	600–2590	2000	1350	200	245	275	145	288	990	4	On request

Attachment not recommended for clamping between forks

Options

	RRP
	Euro
2 hydraulic functions – valve block sideshift	630
Separate sideshifter: 100 + 100 mm for ISO/FEM 2	1330
Separate sideshifter: 100 + 100 mm for ISO/FEM 3	1800
Separate sideshifter: 100 + 100 mm for ISO/FEM 4	2140
2 hydraulic functions – Independent arm control	965
Quick-release lower mountings, class 2 or class 3	605
Quick-release lower mountings, class 4	810

Available on request

- Pockets for forks with different dimensions
- Other opening ranges

See this attachment in action



WA-T

1600 kg
5000 kg

Wide-opening fork positioner with FEM fork carriers and valve block sideshifter

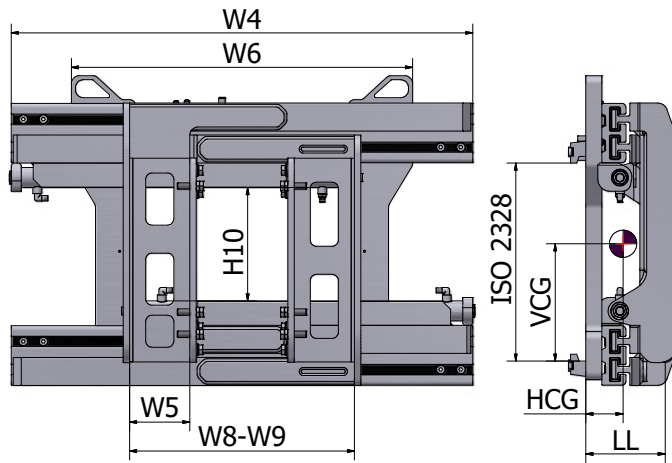

Product info

- W6 – Minimum carriage width
- W5 – Fork adapter width
- Maximum advised fork length: 1600 mm (FEM 2–FEM 3)
- With integrated sideshifter
- Standard forks can be easily fitted
- Valve block with flow divider



Model	Capacity	W8–W9 mm	W4 mm	W6 mm	W5 mm	H10 mm	LL mm	HCG mm	VCG mm	Weight kg	ISO 2328	RRP
	kg/mm											Euro
WA16-AOT	1600/500	560–1740	950	750	130	210	190	86	254	274	2	5819
WA16-BOT	1600/500	560–1840	1050	750	130	210	190	86	254	284	2	6037
WA16-COT	1600/500	560–1940	1150	750	130	210	190	86	254	298	2	6256
WA20-AOT	2000/500	560–1740	950	750	130	210	190	86	256	277	2	5980
WA20-BOT	2000/500	560–1840	1050	750	130	210	190	86	256	287	2	6198
WA20-COT	2000/500	560–1940	1150	750	130	210	190	86	256	301	2	6417
★ WA23-AOT	2300/500	560–1740	950	750	130	210	190	86	258	280	2	6463
★ WA23-BOT	2300/500	560–1840	1050	750	130	210	190	86	258	290	2	6682
WA23-COT	2300/500	560–1940	1150	750	130	210	190	86	258	304	2	6900
★ WA30-AOT	3000/500	560–1840	1050	800	150	285	198	92	297	324	3	6883
★ WA30-BOT	3000/500	560–1940	1150	900	150	285	198	93	294	335	3	7101
★ WA30-COT	3000/500	560–2100	1320	900	150	285	198	93	291	358	3	7320
WA35-AOT	3500/500	560–1840	1050	800	150	285	200	91	294	337	3	7211
WA35-BOT	3500/500	560–1940	1150	900	150	285	200	92	292	348	3	7429
WA35-COT	3500/500	560–2100	1320	900	150	285	200	92	290	369	3	7866
WA40-AOT	4000/500	560–1940	1150	900	150	240	235	99	312	454	3	7757
WA40-BOT	4000/500	560–2100	1320	1000	150	240	235	99	312	488	3	8194
WA40-COT	4000/500	560–2400	1600	1050	150	240	235	99	312	546	3	8959
★ WA45-AOT	4500/500	560–1940	1150	900	150	240	235	99	314	458	3	8303
WA45-BOT	4500/500	560–2100	1320	1000	150	240	235	99	314	492	3	8740
WA45-COT	4500/500	560–2400	1600	1050	150	240	235	99	314	550	3	9505
WA50-AOT	5000/500	560–1940	1150	900	150	240	235	99	316	462	3	10058
★ WA50-BOT	5000/500	560–2100	1320	1000	150	240	235	99	316	495	3	10518
WA50-COT	5000/500	560–2400	1600	1050	150	240	235	99	316	554	3	11323

★ Suggested selection

Attachment not recommended for clamping between forks

Wide-opening fork positioner with FEM fork carriers and valve block sideshifter

WA-T

5500 kg
9000 kg

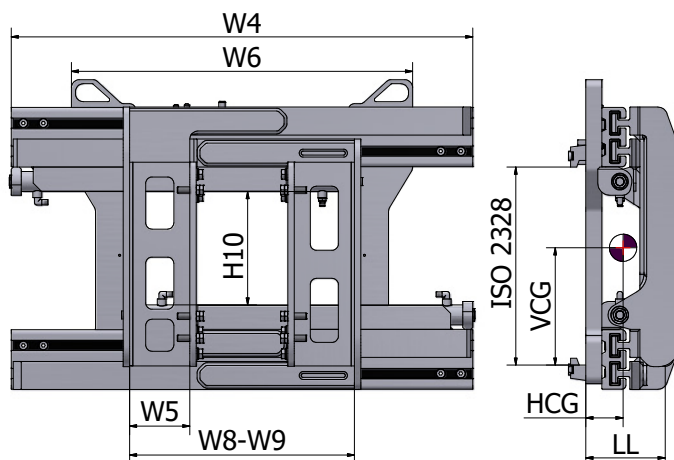

Product info

- W6 – Minimum carriage width
- W5 – Fork adapter width
- Maximum advised fork length: 2000 mm (FEM 4)
- With integrated sideshifter
- Standard forks can be easily fitted
- Valve block with flow divider



Model	Capacity	W8–W9 mm	W4 mm	W6 mm	W5 mm	H10 mm	LL mm	HCG mm	VCG mm	Weight kg	ISO 2328	RRP
	kg/mm											Euro
★ WA55-AOT	5500/600	560–2100	1320	1000	200	330	250	115	289	600	4	12212
WA55-BOT	5500/600	560–2400	1600	1050	200	330	250	112	280	685	4	13777
WA65-AOT	6500/600	560–2380	1600	1050	200	330	250	109	291	785	4	15552
WA65-BOT	6500/600	560–2580	1800	1200	200	330	250	107	290	835	4	16242
WA80-AOT	8000/600	660–2390	1800	1250	200	250	275	135	290	920	4	On request
WA90-AOT	9000/600	600–2590	2000	1350	200	245	275	145	288	990	4	On request

★ Suggested selection

Attachment not recommended for clamping between forks

Options

	RRP
	Euro
2 hydraulic functions – Independent arm control	965
Quick-release lower mountings, class 2 or class 3	605
Quick-release lower mountings, class 4	810

See this attachment in action



PHR

2500 kg
3500 kg

Rotating fork positioner with FEM fork carriers 360°

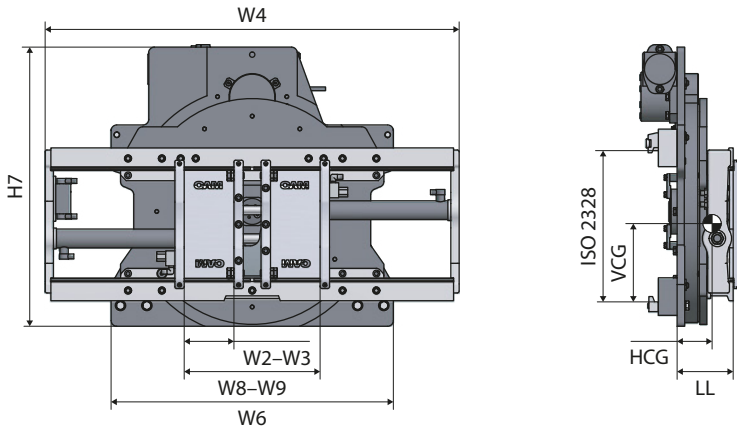

Product info

- W6 – Minimum carriage width
- Technical data without forks
- Without sideshifter
- Maximum advised fork length: 1400 mm
- Standard forks can be easily fitted



Model	Capacity	W8-W9 mm	W4 mm	W6 mm	W2-W3 mm	H7 mm	LL mm	HCG mm	VCG mm	Weight kg	ISO 2328	RRP
	kg/mm											Euro
PHR25.092	2500/500	360-850	920	750	100-125	677	199	95	270	283	2	10080
PHR25.102	2500/500	360-950	1020	750	100-125	677	199	97	270	288	2	10160
PHR25.110	2500/500	360-1030	1100	750	100-125	677	199	98	270	292	2	10320
PHR25.115	2500/500	360-1080	1150	750	100-125	677	199	99	270	295	2	10560
PHR35.110	3500/500	430-1030	1100	900	100-130	775	213	105	320	378	3	12640
PHR35.115	3500/500	430-1080	1150	900	100-130	775	213	106	320	383	3	12740
PHR35.125	3500/500	430-1180	1250	900	100-130	775	213	107	320	391	3	12830

Attachment not recommended for clamping between forks
We recommend forks with reinforced lower brackets.

Options

	RRP
	Euro
Separate sideshifting 100 + 100 mm for ISO/FEM 2	1330
Separate sideshifting 100 + 100 mm for ISO/FEM 3	1800
Quick-release lower mountings, class 2 or class 3	605

Available on request

- Load backrest
- Upper and lower bronze bushings
- Model with automatic synchronism
- Rotator forks with reinforced lower bracket

Advantages

- Easy to install
- Expertly manufactured
- Superior mechanical strength

Rotating fork positioner with pin-type forks 360°

PFR

2500 kg
6000 kg

Product info

- W6 – Minimum carriage width
- Technical data with forks
- Self-lubricating upper sliding bushings
- With chrome round upper bar
- Without sideshifter

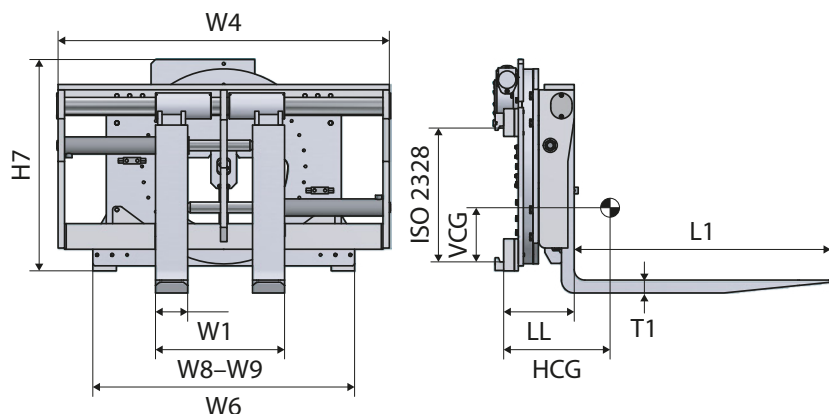

Model	Capacity forks	Capacity rotation	W8–W9	W4	W6	Forks L1 x W1 x T1	H7	LL	HCG	VCG	Weight	ISO 2328	RRP
	kg/mm	kg/mm											mm
PFR25.104	2500/500	2000/500	320–970	1040	750	1200 x 120 x 40	742	248	229	217	435	2A	10870
PFR25.110	2500/500	2000/500	320–1030	1100	750	1200 x 120 x 40	742	248	229	218	438	2A	10970
PFR25.120	2500/500	2000/500	320–1130	1200	750	1200 x 120 x 40	742	248	227	219	446	2A	11210
PFR25.130	2500/500	2000/500	320–1230	1300	750	1200 x 120 x 40	742	248	227	220	454	2A	11810
PFR35.110	3500/500	2800/500	310–1010	1100	900	1200 x 120 x 50	775	255	231	285	564	3A	12800
PFR35.120	3500/500	2800/500	310–1110	1200	900	1200 x 120 x 50	775	255	230	286	578	3A	13000
PFR35.130	3500/500	2800/500	310–1210	1300	900	1200 x 120 x 50	775	255	230	287	592	3A	13200
PFR35.140	3500/500	2800/500	310–1310	1400	900	1200 x 120 x 50	775	255	230	288	606	3A	13800
PFR50.110	5000/500	3500/500	420–1010	1100	1050	1200 x 150 x 50	840	269	239	278	712	3A	14320
PFR50.120	5000/500	3500/500	420–1110	1200	1050	1200 x 150 x 50	840	269	238	279	720	3A	14480
PFR50.130	5000/500	3500/500	420–1210	1300	1050	1200 x 150 x 50	840	269	237	280	728	3A	14650
PFR50.140	5000/500	3500/500	420–1310	1400	1050	1200 x 150 x 50	840	269	236	281	735	3A	15440
PFR60.155	6000/600	4000/600	570–1430	1550	1250	1200 x 150 x 60	989	330	258	385	1126	4A	24680
PFR60.180	6000/600	4000/600	570–1700	1800	1250	1200 x 150 x 60	989	330	258	392	1158	4A	25700

Attachments not recommended for clamping between forks

Options

	RRP
	Euro
Separate sideshifter: 100 + 100 mm for ISO/FEM 2	1330
Separate sideshifter: 100 + 100 mm for ISO/FEM 3	1800
Separate sideshifter: 100 + 100 mm for ISO/FEM 4	2140
Class 2 or class 3 quick-release lower mountings	605
Class 4 quick-release lower mountings	810

Available on request

- Load backrest
- Class B forks
- Different fork dimensions
- Quick-release lower mountings

HFR**1600 kg
2500 kg**

Rotating fork clamp 360°

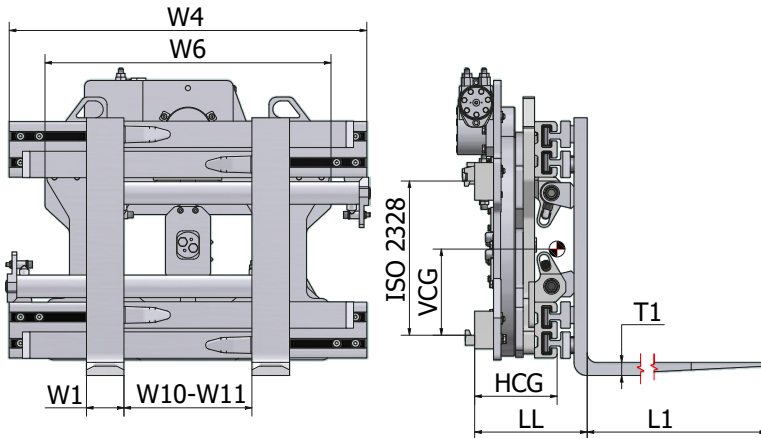

Product info

- 360° rotation
- Continuous rotation in both directions
- Fast rotation and high torque
- Block valve with flow divider for excellent fork synchronization
- Pressure-regulating valve
- Excellent visibility through the frame
- W6 – Minimum carriage width
- Welded forks
- Without sideshifter



Model	Capacity forks	Capacity clamp	W10–W11	W4	W6	Forks L1 x W1 x T1	H10	LL	HCG	VCG	Weight	ISO 2328	RRP
	kg/mm	kg/mm											mm
HFR10-B0-12*	1600/500	1000/500	340–1480	950	750	1200 x 100 x 35	195	299	219	229	492	2A	13580
HFR10-C0-12*	1600/500	1000/500	350–1590	1050	750	1200 x 100 x 35	195	299	218	230	508	2A	13840
HFR14-BQ1-12*	2000/500	1400/500	310–1420	950	750	1200 x 100 x 40	195	304	231	225	506	2A	13970
HFR14-B0-12	2000/500	1400/500	450–1690	950	750	1200 x 100 x 40	195	304	229	227	510	2A	13970
★ HFR14-C0-12*	2000/500	1400/500	350–1590	1050	750	1200 x 100 x 40	195	304	229	226	522	2A	14280
HFR14-D0-12	2000/500	1400/500	550–1980	1150	750	1200 x 100 x 40	195	304	229	225	538	2A	14590
HFR18-AQ1-12*	2300/500	1800/500	330–1450	950	750	1200 x 100 x 40	185	309	229	235	520	2A	14650
HFR18-A0-12	2300/500	1800/500	480–1700	950	750	1200 x 100 x 40	185	304	228	227	506	2A	14650
HFR18-B0-12*	2300/500	1800/500	360–1580	1050	750	1200 x 100 x 40	185	304	228	226	526	2A	15000
HFR18-B1-12	2300/500	1800/500	480–1800	1050	750	1200 x 100 x 40	185	304	228	225	540	2A	15000
HFR18-CQ0-12*	2300/500	1800/500	250–1470	1150	750	1200 x 100 x 40	185	309	229	235	560	2A	15330
HFR18-C0-12	2300/500	1800/500	480–1920	1150	750	1200 x 100 x 40	185	309	229	235	570	2A	15330
HFR18-D0-12*	2300/500	1800/500	360–1780	1250	750	1200 x 100 x 40	185	309	229	235	585	2A	15650
HFR22-A0-12	2500/500	2200/500	430–1660	950	750	1200 x 120 x 40	180	309	248	226	550	2A	15490
HFR22-B1-12*	2500/500	2200/500	300–1520	1050	750	1200 x 120 x 40	180	309	247	225	559	2A	15590
HFR22-C0-12	2500/500	2200/500	450–1900	1150	750	1200 x 120 x 40	180	309	246	224	580	2A	15920
HFR22-D1-12*	2500/500	2200/500	320–1740	1250	750	1200 x 120 x 40	180	309	243	223	600	2A	16290

★ Suggested selection

* Model for Euro-pallets

Options

	RRP
	Euro
Separate sideshifter: 100 + 100 mm for ISO/FEM 2	1330
Quick-release lower mountings, class 2	605
Double maximum pressure control valves	685
Frame bumper	260

Rotating fork clamp 360°

HFR

3200 kg
5000 kg

Product info

- 360° rotation
- Continuous rotation in both directions
- Fast rotation and high torque
- Block valve with flow divider for excellent fork synchronization
- Pressure-regulating valve
- Excellent visibility through the frame
- W6 – Minimum carriage width
- Welded forks
- without sidershifter

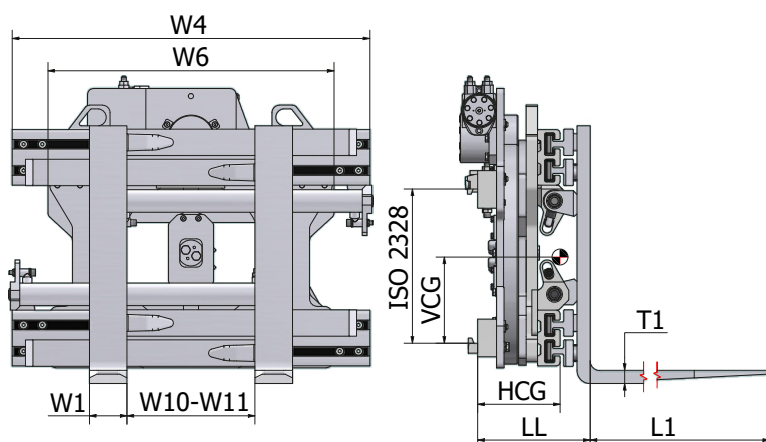

Model	Capacity forks	Capacity clamp	W10–W11	W4	W6	Forks L1 x W1 x T1	H10	LL	HCG	VCG	Weight	ISO 2328	RRP
	kg/mm	kg/mm									mm		mm
HFR26-AQ1-12*	3200/500	2600/500	260–1450	1050	900	1200 x 120 x 45	180	317	243	256	618	3A	16080
HFR26-A0-12	3200/500	2600/500	440–1790	1050	900	1200 x 120 x 45	180	308	240	252	604	3A	16080
★ HFR26-B1-12*	3200/500	2600/500	300–1620	1150	900	1200 x 120 x 45	180	308	239	253	620	3A	16470
HFR26-CQ1-12*	3200/500	2600/500	250–1620	1250	900	1200 x 120 x 45	180	308	239	256	645	3A	16820
HFR26-C0-12	3200/500	2600/500	440–1980	1250	900	1200 x 120 x 45	180	317	241	256	655	3A	16820
HFR26-D1-12*	3200/500	2600/500	320–1810	1320	900	1200 x 120 x 45	180	317	239	256	674	3A	17030
HFR30-A0-12*	3600/500	2800/500	320–1610	1150	900	1200 x 120 x 50	175	352	257	293	799	3A	17960
HFR30-B0-12	3600/500	2800/500	450–1970	1250	900	1200 x 120 x 50	175	352	256	295	825	3A	18230
HFR30-C0-12*	3600/500	2800/500	320–1780	1320	900	1200 x 120 x 50	175	352	255	297	840	3A	18480
HFR35-A0-12*	4200/500	3500/500	260–1560	1150	1050	1200 x 150 x 50	170	352	275	283	845	3A	21000
HFR35-B0-12*	4200/500	3500/500	250–1730	1320	1050	1200 x 150 x 50	170	352	272	286	889	3A	21600
HFR35-C0-12	4200/500	3500/500	390–2120	1450	1050	1200 x 150 x 50	170	352	269	289	950	3A	21890
HFR40-A0-12*	4800/500	4000/500	260–1560	1150	1050	1200 x 150 x 60	165	380	256	279	1015	3A	22420
HFR40-B0-12	4800/500	4000/500	450–2050	1320	1050	1200 x 150 x 60	165	380	259	279	1050	3A	22630
HFR40-C0-12	4800/500	4000/500	450–2180	1450	1050	1200 x 150 x 60	165	380	263	279	1090	3A	22910
HFR45-A0-12	5000/600	3800/600	350–1970	1450	1230	1200 x 150 x 60	210	400	277	377	1252	4A	25700
HFR45-B0-12	5000/600	3800/600	450–2320	1600	1230	1200 x 150 x 60	210	400	277	380	1306	4A	25950
HFR45-C0-12*	5000/600	3800/600	260–1660	1320	1230	1200 x 150 x 60	210	400	277	375	1205	4A	29910

★ Suggested selection

* Model for Euro-pallets

Options

	RRP
	Euro
Separate sidershifter: 100 + 100 mm for ISO/FEM 3	1800
Separate sidershifter: 100 + 100 mm for ISO/FEM 4	2140
Quick-release lower mountings, class 3	605
Quick-release lower mountings, class 4	810
Double maximum pressure control valves	685
Frame bumper	260

Technical data

Fork positioners

Model	Positioning						Sideshifting						Hydraulic functions
	Operating pressure			Oil flow rate			Operating pressure			Oil flow rate			
	Min.	Recom- mended	Max.	Min.	Recom- mended	Max.	Min.	Recom- mended	Max.	Min.	Recom- mended	Max.	
PH25 – PH35	80	160	240	5	16	25	-	-	-	-	-	-	1
PH50 – PH55	80	160	240	8	16	30	-	-	-	-	-	-	1
PH70 – PH120	100	160	240	8	16	35	-	-	-	-	-	-	1
PH25T – PH35T	80	160	240	5	16	25	130	160	220	6	12	18	2
PH50T – PH55T	80	160	240	8	16	30	130	160	220	6	12	18	2
PH70T – PH120T	100	160	240	8	16	35	130	160	220	7	14	25	2
PL25 – PL35	80	160	220	5	16	25	-	-	-	-	-	-	1
PL50	80	160	220	8	16	30	-	-	-	-	-	-	1
PL25T – PL35T	80	160	220	5	16	25	130	160	220	6	12	18	2
PL50T	80	160	220	8	16	30	130	160	220	6	12	18	2
PJ20T – PJ35T	80	160	220	8	16	30	130	160	220	8	15	25	2
PJ50T – PJ55T	80	160	220	8	16	30	130	160	220	10	15	25	2
PJA20T – PJA35T	80	160	220	8	16	30	130	160	220	8	15	25	2
PJA50T – PJA55T	80	160	220	8	16	30	130	160	220	10	15	25	2
PJI20T – PJI35T	80	160	220	8	16	30	130	160	220	8	15	25	2
PJI50T – PJI55T	80	160	220	8	16	30	130	160	220	10	15	25	2
PF25	80	160	220	5	16	25	-	-	-	-	-	-	1
PF50	80	160	220	8	20	30	-	-	-	-	-	-	1
PF60 – PF120	100	160	220	12	20	40	-	-	-	-	-	-	1
PF25T	80	160	220	5	10	25	130	160	220	6	12	18	2
PF50T	80	160	220	8	20	30	130	160	220	6	12	18	2
PF60T – PF120T	100	160	220	12	20	40	130	160	220	7	14	25	2
PFA25 – PFA35	80	160	220	5	16	25	-	-	-	-	-	-	1
PFA50	80	160	220	8	20	30	-	-	-	-	-	-	1
PFA60 – PFA120	100	160	220	12	20	40	-	-	-	-	-	-	1
PFA25T – PFA35T	80	160	220	5	16	25	130	160	220	6	12	18	2
PFA50T	80	160	220	8	20	30	130	160	220	6	12	18	2
PFA60T – PFA120T	100	160	220	12	20	40	130	160	220	7	14	25	2
PK25 – PK35	80	160	240	5	16	25	-	-	-	-	-	-	1
PK50	80	160	240	5	16	25	-	-	-	-	-	-	1
PK60	100	160	240	12	20	60	-	-	-	-	-	-	1
PK25TS – PK35TS	80	160	240	5	16	25	130	160	220	6	12	18	2
PK50TS	80	160	240	5	16	25	130	160	220	6	12	18	2
PK60TS	160	160	240	12	20	60	130	160	230	10	14	25	1
PKF25 – PKF35	80	160	240	5	16	25	-	-	-	-	-	-	1
PKF50	80	160	240	5	16	25	-	-	-	-	-	-	1
PKF25TS – PKF35TS	80	160	240	5	16	25	130	160	220	6	12	18	2
PKF50TS	80	160	240	5	16	25	130	160	220	6	12	18	2
PR100 – PR120	100	160	220	20	35	50	-	-	-	-	-	-	1
PRI100 – PRI120	100	160	220	20	35	50	-	-	-	-	-	-	1
PRA100 – PRA120	100	160	220	20	35	50	-	-	-	-	-	-	1
WF16 – WF23	80	160	220	12	20	30	-	-	-	-	-	-	1
WF30 – WF45	100	160	220	12	20	30	-	-	-	-	-	-	1
WF55 – WF90	100	160	220	15	25	40	-	-	-	-	-	-	1
WA16 – WA23	80	160	220	12	20	30	-	-	-	-	-	-	1
WA30 – WA50	100	160	220	12	20	30	-	-	-	-	-	-	1
WA55 – WA90	100	160	220	15	25	40	-	-	-	-	-	-	1
WA16T – WA23T	80	160	220	12	20	30	140	160	220	15	15	25	2
WA30T – WA50T	100	160	220	12	20	30	140	160	220	15	15	25	2
WA55T – WA90T	100	160	220	15	25	40	140	160	220	15	18	30	2

Standard hose kit for separate sidershifter

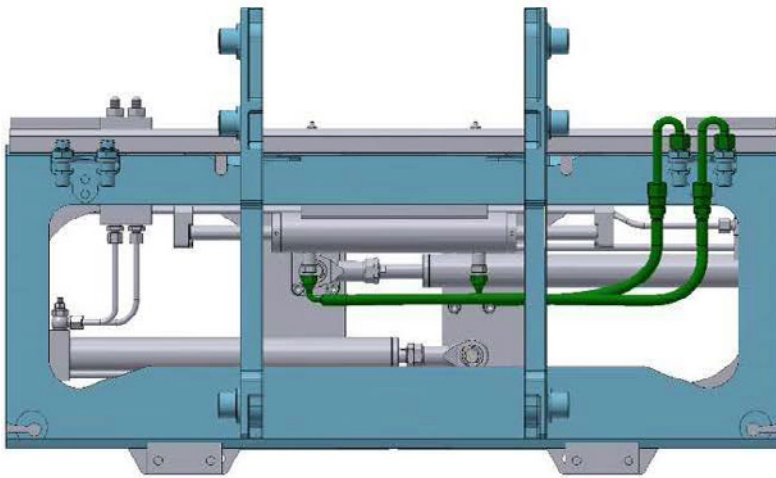

Code	Description	Gross price*
KIT.H.TS2	For separate sidershift FEM2	€370 ea
KIT.H.TS3	For separate sidershift FEM3	€370 ea
KIT.H.TS4	For separate sidershift FEM4	€370 ea

KIT INCLUDE 2X HOSES AND FITTINGS
CONNECTION TO LIFT TRUCK M2OX1,5 (12S)

*Prices apply when ordered together with an attachment

Connection Hose Configurator



Fitting dimension
Lift truck side

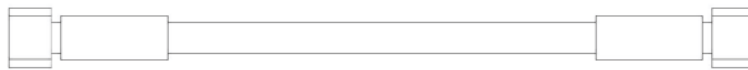

Hose Dimension



Fitting dimension
Attachments side

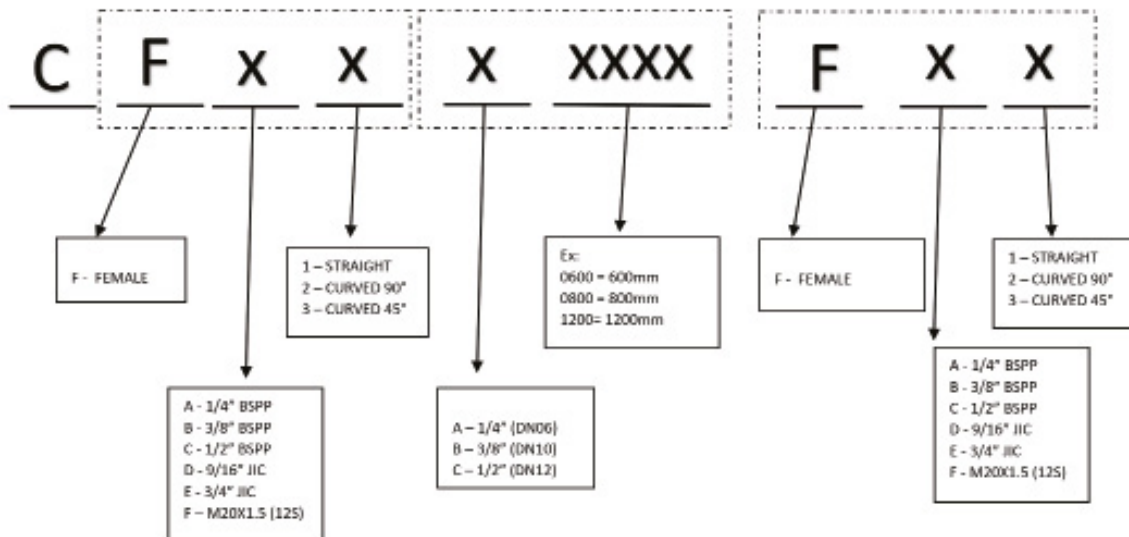

GROSS PRICE*: €135 ea

Accessories

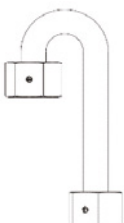

SPECIAL 180° FITTING
M20X1.5 BOTH TERMINALS

[C035414](#)

GROSS PRICE*: € 50 ea



Quick Release Coupling

Code	A	B	GROSS PRICE*
C035023.F	1/2" FEMALE	1/2" FEMALE	€60 ea
C035024.F	1/2" FEMALE	M20x1.5 (12S) MALE	€60 ea
C035025.F	3/8" FEMALE	3/8" FEMALE	€60 ea

*Prices apply when ordered together with an attachment



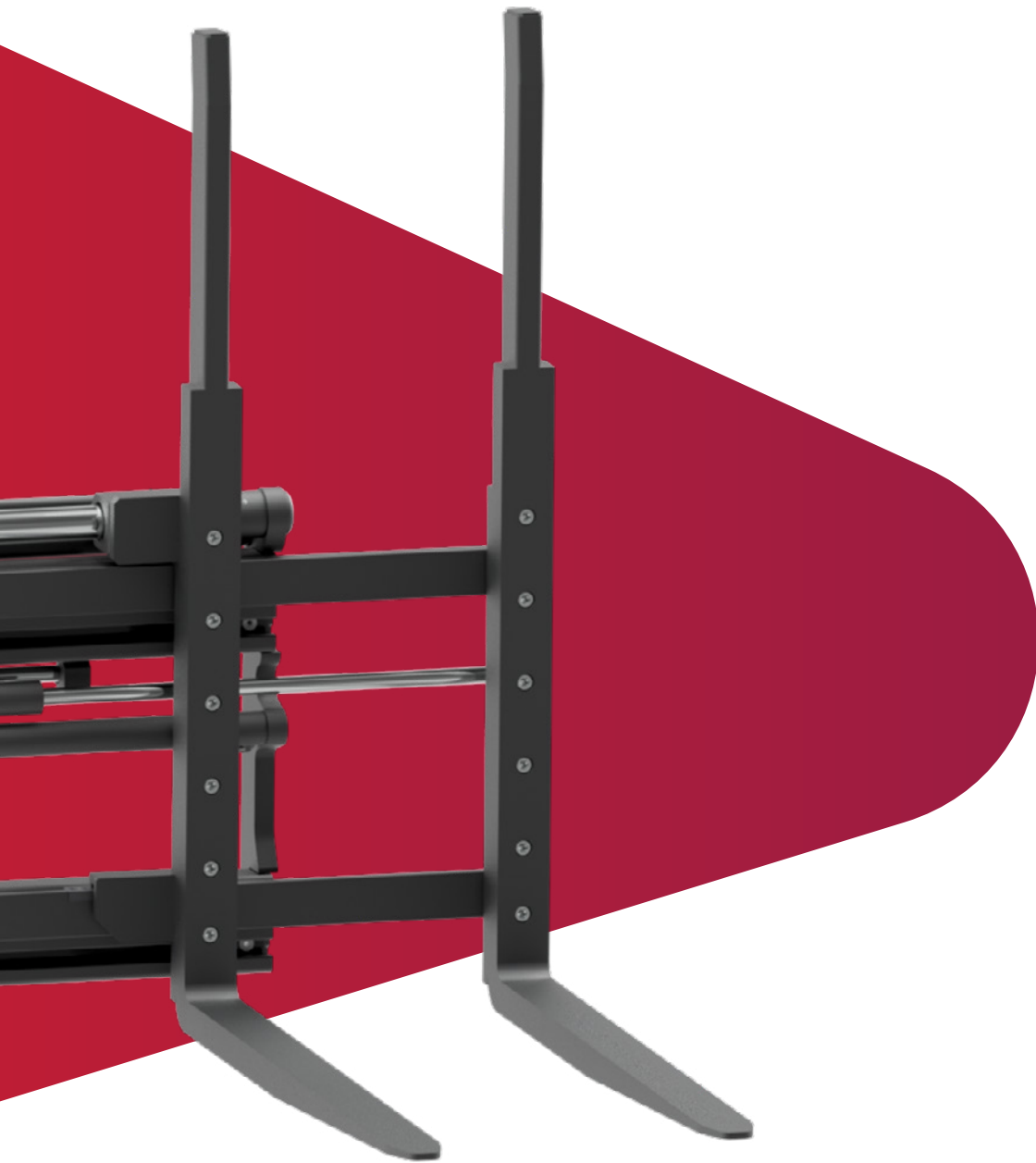

3. Multi-fork positioners

Do you need to handle multiple pallets at once? Or do you want to increase productivity? This can be done with multi-fork positioners! We offer four-fork positioners for two pallets and six-fork positioners for three pallets.

DPS

1600 kg
2600 kg

Four-fork positioner for multi-pallets

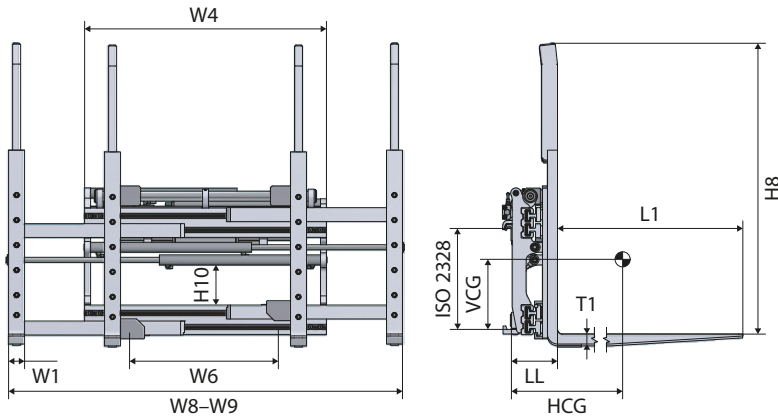

Product info

- W6 – Minimum carriage width
- With separate sideshifter
- Total sideshifter stroke: 100 + 100 mm
- Integrated flow divider
- Bolted forks
- Valve block with flow divider for better synchronization of the forks



Model	Capacity	W8-W9	W4	W6	Forks L1 x W1 x T1	H8	H10	LL	HCG	VCG	Weight	ISO 2328	RRP
	kg/mm												mm
Model for europallets (800 x 1200 mm)													
DPS16	1600/600	560-1720	960	800	1150 x 80 x 50	1450	160	230	245	295	551	2A	9240
DPS18	1800/600	560-1970	1210	800	1150 x 80 x 50	1450	160	230	234	296	597	2A	9240
★ DPS25.2	2500/600	560-1970	1210	850	1150 x 80 x 50	1450	150	222	226	298	598	2A	9240
★ DPS25	2500/600	560-1970	1210	900	1150 x 80 x 50	1450	200	232	219	334	645	3A	9240
★ DPS32	3200/600	560-1970	1210	900	1150 x 80 x 50	1450	200	232	220	338	647	3A	10349
DPS36	3600/600	560-1970	1230	900	1150 x 80 x 60	1450	190	275	235	335	838	3A	11946
DPS40.3	4000/600	560-1970	1230	900	1150 x 80 x 60	1450	250	275	227	362	850	3A	11947
DPS40	4000/600	560-1970	1230	900	1150 x 80 x 60	1450	250	275	225	365	878	4A	11946
DPS50.3	5000/600	560-1970	1250	950	1150 x 80 x 60	1450	250	275	228	362	880	3A	12342
DPS50	5000/600	560-1970	1250	950	1150 x 80 x 60	1450	250	275	228	362	882	4A	12340
DPS1812	1800/1200	560-1970	1250	950	2350 x 80 x 65	1450	250	285	517	312	1090	3A	16020
DPS1812.4	1800/1200	560-1970	1250	950	2350 x 80 x 65	1450	250	285	509	332	1100	4A	16682
DPS2612.3	2600/1200	560-1970	1300	950	2350 x 80 x 70	1450	250	275	528	311	1200	3A	18963
DPS2612	2600/1200	560-1970	1300	950	2350 x 80 x 70	1450	250	290	519	329	1220	4A	20589

★ Suggested selection

Attachment not recommended for clamping between forks

Advantages

- Expertly manufactured
- Superior mechanical strength
- Time-saving
- Multiple pallet handling for increased efficiency

Available on request

- Models without sideshifters
- Other fork dimensions
- Models with load stabiliser

See this attachment in action



Four-fork positioner for multi-pallets

DPS

1600 kg
2600 kg

Product info

- W6 – Minimum carriage width
- With separate sideshifter
- Total sideshifter stroke: 100 + 100 mm
- Integrated flow divider
- Bolted forks
- Valve block with flow divider for better synchronization of the forks

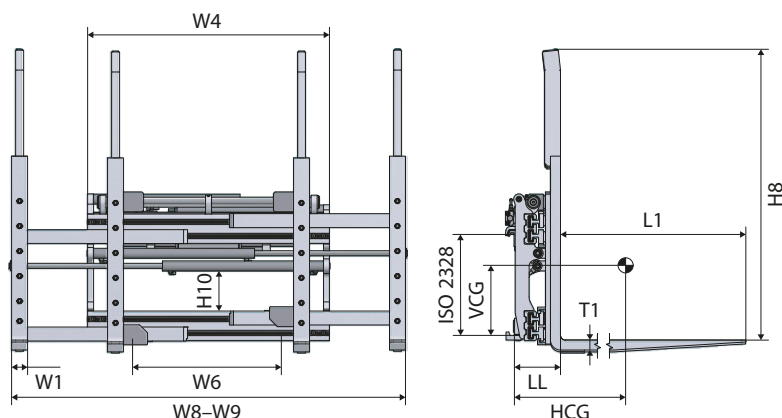

Model	Capacity	W8-W9	W4	W6	Forks L1 x W1 x T1	H8	H10	LL	HCG	VCG	Weight	ISO 2328	RRP
	kg/mm												mm
Model for international pallets (1000 x 1200 mm)													
DPS16A	1600/600	660-1820	960	800	1150 x 80 x 50	1450	160	230	245	295	557	2A	9240
DPS18A	1800/600	660-2070	1210	800	1150 x 80 x 50	1450	160	230	232	297	605	2A	9240
★ DPS25A.2	2500/600	660-2070	1210	850	1150 x 80 x 50	1450	150	222	226	298	618	2A	9240
★ DPS25A	2500/600	660-2070	1210	900	1150 x 80 x 50	1450	200	232	218	336	650	3A	9240
DPS32A	3200/600	660-2070	1210	900	1150 x 80 x 50	1450	200	232	220	338	652	3A	10349
DPS36A	3600/600	660-2070	1230	900	1150 x 80 x 60	1450	190	275	235	335	849	3A	11946
DPS40A.3	4000/600	660-2070	1230	900	1150 x 80 x 60	1450	250	275	227	362	856	3A	11947
DPS40A	4000/600	660-2070	1230	900	1150 x 80 x 60	1450	250	275	225	364	883	4A	11946
DPS50A.3	5000/600	660-2070	1230	900	1150 x 80 x 60	1450	250	275	227	362	887	3A	12342
DPS50A	5000/600	660-2070	1230	900	1150 x 80 x 60	1450	250	275	227	362	889	4A	12340
DPS1812A	1800/1200	660-2070	1250	950	2350 x 80 x 65	1450	250	285	529	245	1095	3A	16020
DPS1812A.4	1800/1200	660-2070	1250	950	2350 x 80 x 65	1450	250	285	509	331	1105	4A	16682
DPS2612A.3	2600/1200	660-2070	1300	950	2350 x 80 x 70	1450	250	275	528	310	1205	3A	18963
DPS2612A	2600/1200	660-2070	1300	950	2350 x 80 x 70	1450	250	290	519	328	1225	4A	20589

★ Suggested selection

Attachment not recommended for clamping between forks

Advantages

- Expertly manufactured
- Superior mechanical strength
- Time-saving
- Multiple pallet handling for increased efficiency

Available on request

- Models without sideshifters
- Other fork dimensions
- Models with load stabiliser

See this attachment in action



TPS

3000 kg
4500 kg

Six-fork positioner for multi-pallets

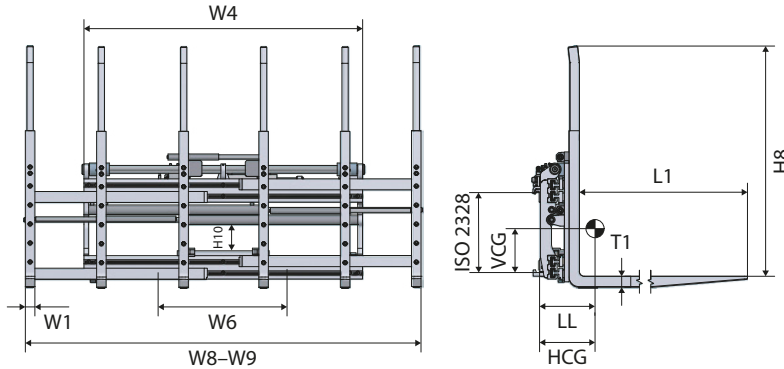

Product info

- W6 – Minimum carriage width
- With separate sideshifter
- Total sideshifter stroke: 100 + 100 mm
- Integrated flow divider
- Bolted forks
- Valve block with flow divider for better synchronization of the forks



Model	Capacity	W8-W9	W4	W6	Forks L1 x W1 x T1	H8	H10	LL	HCG	VCG	Weight	ISO 2328	RRP
	kg/mm												mm
Model for europallets (800 x 1200 mm)													
TPS30.156	3000/600	560-2300	1560	1100	1150 x 60 x 50	1450	195	240	231	307	755	3A	17660
TPS30.166	3000/600	560-2400	1660	1100	1150 x 60 x 50	1450	195	240	225	294	775	3A	17930
TPS30.176	3000/600	560-2500	1760	1100	1150 x 60 x 50	1450	195	240	223	310	795	3A	17990
TPS36.156	3600/600	560-2300	1560	1100	1150 x 60 x 60	1450	195	250	246	300	813	3A	19490
TPS36.166	3600/600	560-2400	1660	1100	1150 x 60 x 60	1450	195	250	246	300	825	3A	19970
TPS36.176	3600/600	560-2500	1760	1100	1150 x 60 x 60	1450	195	250	239	301	849	3A	20500
TPS45.166	4500/600	560-2400	1660	1200	1150 x 60 x 65	1450	195	283	232	308	980	4A	20270
TPS45.176	4500/600	560-2500	1760	1200	1150 x 60 x 65	1450	195	283	233	309	1050	4A	21290

Attachment not recommended for clamping between forks

Advantages

- Expertly manufactured
- Superior mechanical strength
- Time-saving
- Multiple pallet handling for increased efficiency

Available on request

- Models without sideshifters
- Other fork dimensions

Six-fork positioner for multi-pallets

TPS
3000 kg
4500 kg

Product info

- W6 – Minimum carriage width
- With separate sideshifter
- Total sideshifter stroke: 100 + 100 mm
- Integrated flow divider
- Bolted forks
- Valve block with flow divider for better synchronization of the forks

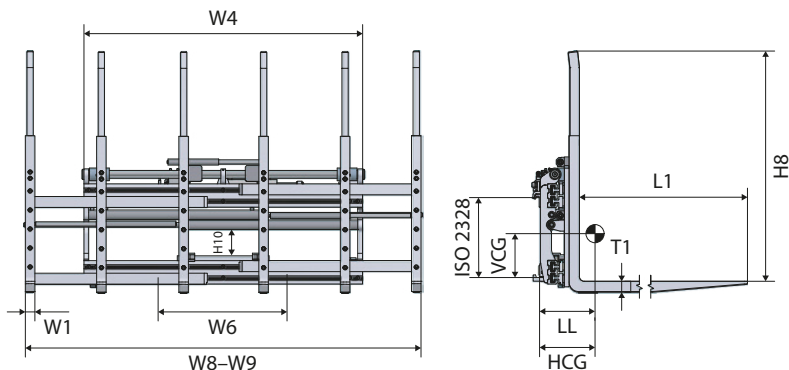

Model	Capacity	W8-W9	W4	W6	Forks L1 x W1 x T1	H8	H10	LL	HCG	VCG	Weight	ISO 2328	RRP
	kg/mm												mm
Model for international pallets (1000 x 1200 mm)													
★ TPS30A	3000/600	660–2900	1960	1100	1150 x 60 x 50	1450	195	240	211	315	805	3A	17820
TPS36A	3600/600	660–2900	1960	1100	1150 x 60 x 60	1450	195	240	213	317	850	3A	19740
TPS45A	4500/600	660–2900	1960	1300	1150 x 60 x 65	1450	195	283	234	310	1144	4A	20360

★ **Suggested selection**

Attachment not recommended for clamping between forks

Advantages

- Expertly manufactured
- Superior mechanical strength
- Time-saving
- Multiple pallet handling for increased efficiency

Available on request

- Models without sideshifters
- Other fork dimensions

Technical data

Multi-fork positioners

Model	Positioning						Sideshifting						Hydraulic functions
	Operating pressure			Oil flow rate			Operating pressure			Oil flow rate			
	Min.	Recom- mended	Max.	Min.	Recom- mended	Max.	Min.	Recom- mended	Max.	Min.	Recom- mended	Max.	
DPS16 – DPS18	100	150	180	15	20	25	130	160	200	7	14	25	2
DPS25 – DPS36	100	150	180	15	20	30	130	160	200	10	14	25	2
DPS40	100	150	180	15	20	40	130	160	200	10	14	25	2
DPS1812	100	150	180	15	20	30	130	160	200	10	14	25	2
DPS1812-4	100	150	180	15	20	30	130	160	200	10	14	25	2
DPS2612	100	150	180	15	20	40	130	160	200	10	14	25	2
DPS2612-4	100	150	180	15	20	40	130	160	200	10	14	25	2
DPS16A – DPS18A	100	150	180	15	20	25	130	160	200	7	14	25	2
DPS25A – DPS36A	100	150	180	15	20	30	130	160	200	10	14	25	2
DPS40A	100	150	180	15	20	40	130	160	200	10	14	25	2
DPS1812A	100	150	180	15	20	30	130	160	200	10	14	25	2
DPS1812-4A	100	150	180	15	20	30	130	160	200	10	14	25	2
DPS2612A	100	150	180	15	20	40	130	160	200	10	14	25	2
DPS2612-4A	100	150	180	15	20	40	130	160	200	10	14	25	2
TPS30 – TPS36	100	150	180	15	25	40	130	160	200	10	14	25	2
TPS45	100	150	180	15	25	40	130	160	200	10	14	25	2
TPS30A – TPS36A	100	150	180	15	25	40	130	160	200	10	14	25	2
TPS45A	100	150	180	15	25	40	130	160	200	10	14	25	2

Notes

A series of horizontal dotted lines for writing notes.

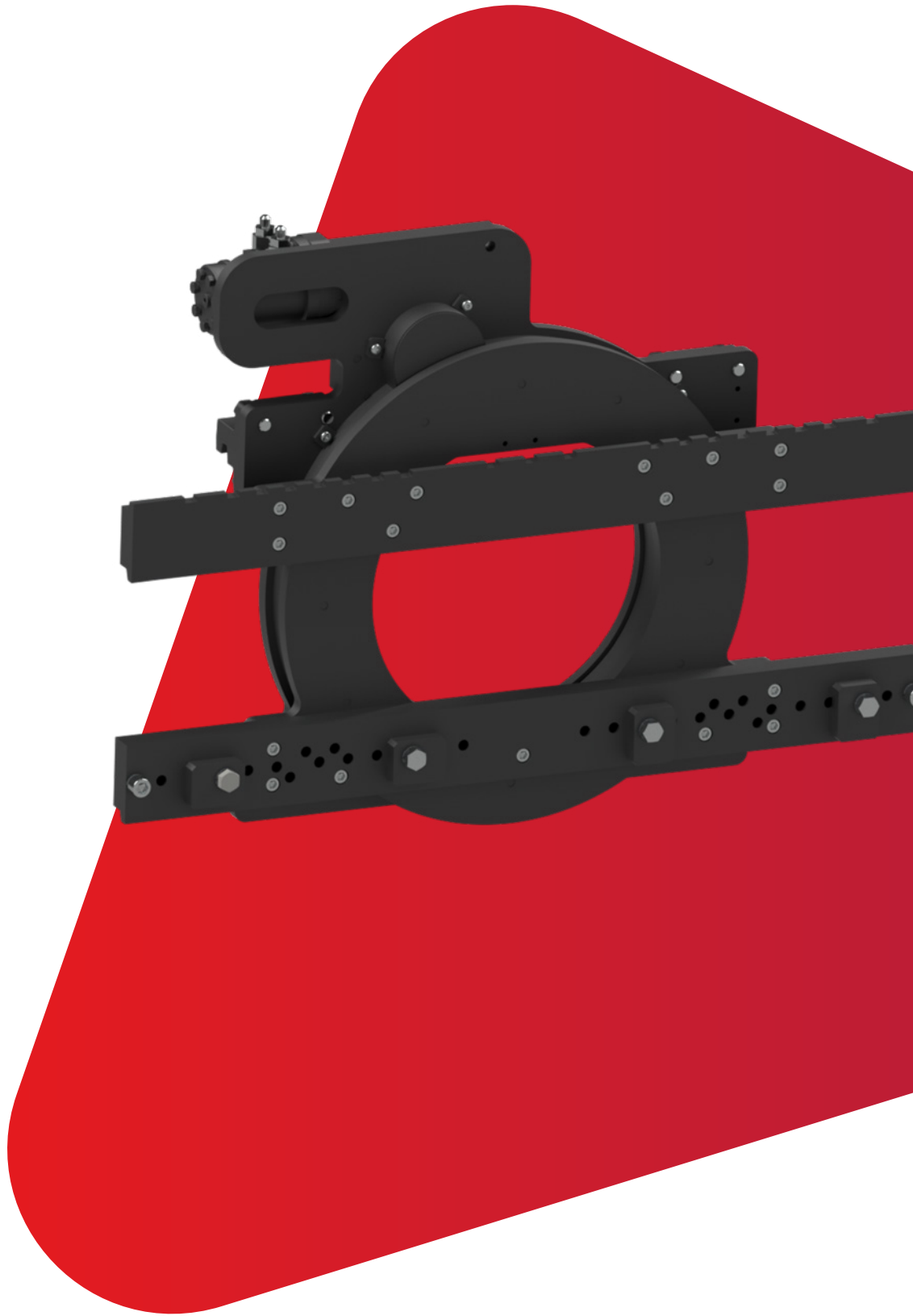

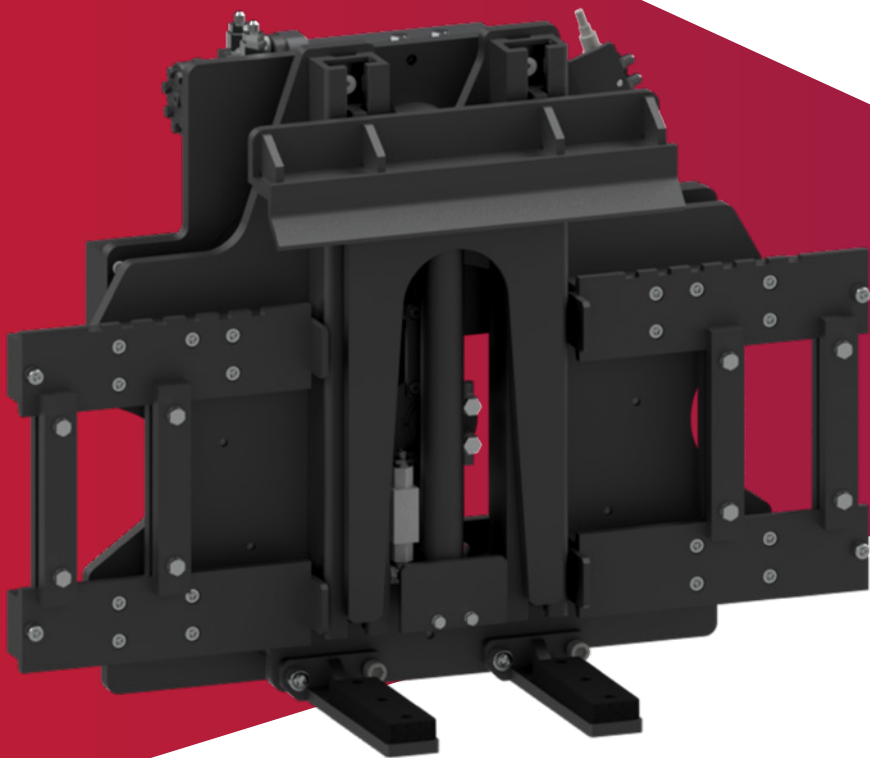

4. Rotators & box rotators

Boost versatility and efficiency with rotators! These attachments allow the operator to easily rotate the forks, making it simpler to move and stack goods and to safely dump loads. Our range includes several types of rotators to suit different professional requirements.

Box rotators help operators to increase productivity and save time when dumping loads. Our wide range includes standard and specialised models such as rotators with hydraulic bin retainers and plastic container rotators.

PRC

360° Rotators

1000 kg
8000 kg

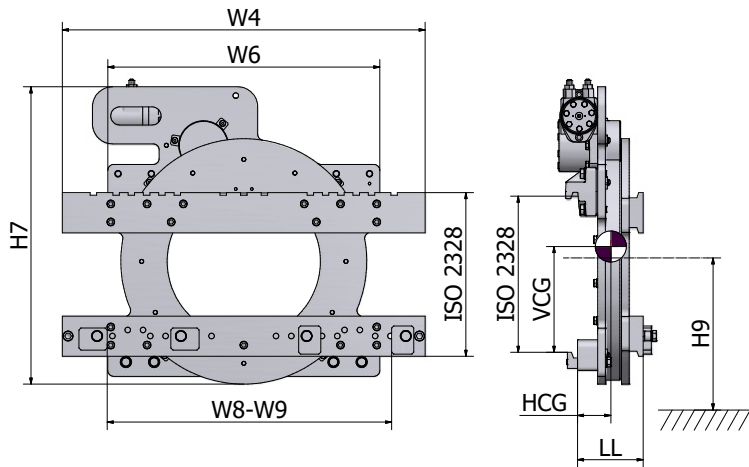

Product info

- 360° rotation
- Continuous rotation in both directions
- Fast rotation and high torque
- Excellent visibility through the plates
- Excellent fork mounting system with additional robust design
- W6 – Minimum carriage width
- RS – Rotations per minute
- Fork bar assembly and locking fork pads included
- Without sideshifter



Model	Capacity	W8-W9	W4	W6	H9	H7	Rotating torque	Rotation speed	LL	HCG	VCG	Weight	ISO 2328	RRP
	kg/mm							mm						
PRC8D	1000/500	200-845	900	680	315	740	7,2	8,3*	163	82	276	203	2	5300
★ PRC18D	1800/500	200-845	900	680	315	740	7,2	8,3*	163	83	277	204	2	5300
★ PRC22D	2200/500	200-1000	1050	680	315	740	7,2	8,3*	163	85	274	212	2	5400
★ PRC28D	2800/500	310-1070	1150	900	415	775	11	6,9	171	93	324	327	3	6400
PRC32D	3200/500	310-1070	1150	900	415	775	14	5,5	171	94	325	331	3	6500
★ PRC40D	4000/500	330-1220	1300	1050	420	840	16	4,8	179	97	331	437	3	8500
★ PRC45D	4500/500	330-1220	1300	1050	420	840	16	4,8	185	100	331	440	3	9700
PRC50D	5000/500	330-1220	1300	1050	420	840	17	4,8	185	100	331	443	3	9950
★ PRC55D	5500/600	380-1195	1300	1250	572	960	18,5	4,3	210	121	412	613	4	13800
★ PRC70D	7000/600	615-1615	1750	1200	590	1060	20,8	3,7	284	154	438	1125	4	21800
PRC80D	8000/600	615-1715	1850	1200	590	1060	20,8	3,7	284	154	439	1145	4	22800

★ Suggested selection

We recommend forks with reinforced lower brackets.

Options

	RRP
	Euro
Foundry kit (front and back cover) FEM 2 and 3	1050
Foundry kit (front and back cover) FEM 4	1345

Available on request

- Different length of fork bars
- Pin-type fork models
- 180° rotation kit
- Third fork hook to weld on the fork for more stability
- Rotator forks with reinforced lower bracket

Advantages

- Improves productivity
- 360° rotation
- Bolted bars to adjust the length
- Well-protected motor

See this attachment in action



Rotator with sideshifter 360°

PRC-T

1000 kg
8000 kg

Product info

- 360° rotation
- Continuous rotation in both directions
- Fast rotation and high torque
- Excellent visibility through the plates
- Excellent fork mounting system with additional robust design
- W6 – Minimum carriage width
- RS – Rotations per minute
- Fork bar assembly and locking fork pads included
- Prices exclude forks
- With separate sideshifter
- Total sideshifter stroke: 100 + 100 mm (FEM 2–FEM 3)
- Total sideshifter stroke: 150 + 150 mm (FEM 4)

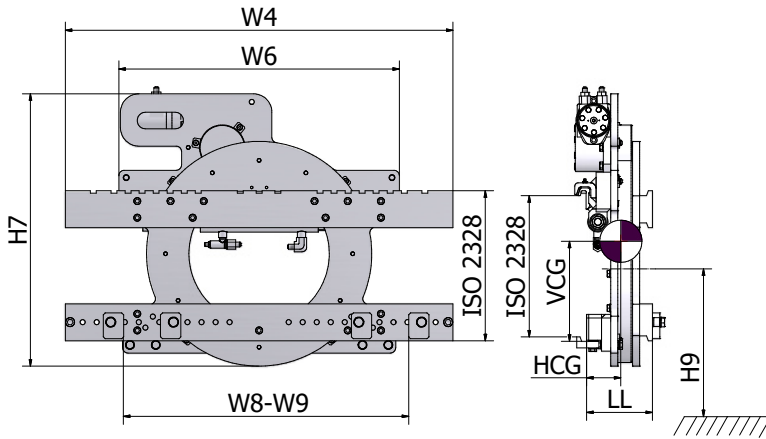

Model	Capacity	W8–W9	W4	W6	H9	H7	Rotating torque	Rotation speed	LL	HCG	VCG	Weight	ISO 2328	RRP
	kg/mm							mm						
PRC8DT	1000/500	200–845	900	760	315	740	7,2	8,3*	185	96	273	226	2	7450
PRC18DT	1800/500	200–845	900	760	315	740	7,2	8,3*	185	96	273	228	2	7450
PRC22DT	2200/500	200–1000	1050	760	315	740	7,2	8,3*	185	96	273	235	2	7600
PRC28DT	2800/500	310–1070	1150	1140	415	775	11	6,9	200	113	345	358	3	9030
PRC32DT	3200/500	310–1070	1150	1140	415	775	14	5,5	200	114	346	362	3	9230
PRC40DT	4000/500	330–1220	1300	1180	420	840	16	4,8	217	121	326	475	3	11150
PRC45DT	4500/500	330–1220	1300	1180	420	840	16	4,8	217	122	327	479	3	12400
PRC50DT	5000/500	330–1220	1300	1050	420	840	17	4,8	185	100	331	443	3	12600
PRC55DT	5500/600	380–1195	1300	1500	572	960	18,5	4,3	245	138	415	713	4	16500
PRC70DT	7000/600	615–1615	1750	1350	590	1060	20,8	3,7	319	180	437	1210	4	24620
PRC80DT	8000/600	615–1715	1850	1350	590	1060	20,8	3,7	319	184	432	1228	4	25570

We recommend forks with reinforced lower brackets.

Advantages

- Improves productivity
- 360° rotation
- Bolted bars for easy width change
- Well-protected motor

Available on request

- Different fork bar lengths
- Pin-type fork models
- 180° rotation kit
- Third fork hook to weld on the fork for greater stability
- Rotator forks with reinforced lower bracket

See this attachment in action



PRC-Z

1000 kg
3200 kg

Rotator without sideshifter 360° marine version

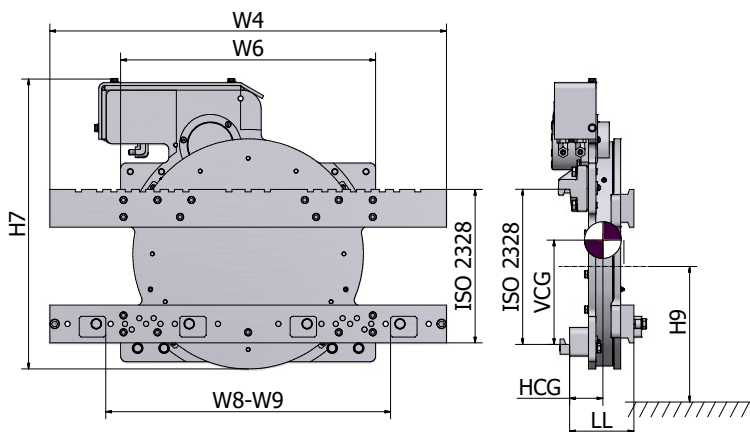

Product info

- 360° rotation
- Continuous rotation in both directions
- Fast rotation and high torque
- W6 – Minimum carriage width
- RS – Rotations per minute
- Fork bar assembly and locking fork pads included
- Prices exclude forks
- Without sideshifter
- Front and back protection to close the centrale hole in the rotators
- Protected gearbox on the reductor
- Special cold galvanising paint
- High-resistance seals for additional bearing protection
- Screw sealed with marine silicone



Model	Capacity	W8-W9	W4	W6	H9	H7	Rotating torque	Rotation speed	LL	HCG	VCG	Weight	ISO 2328	RRP
	kg/mm							mm						
PRC8D.Z	1000/500	200-845	900	680	314	760	7,2	8,3*	170	85	277	253	2	7300
PRC18D.Z	1800/500	200-845	900	680	314	760	7,2	8,3*	170	85	277	255	2	7500
★ PRC22D.Z	2200/500	200-1000	1050	680	314	760	7,2	8,3*	170	85	277	262	2	7700
PRC28D.Z	2800/500	310-1070	1150	900	415	775	11	6,9	177	95	326	388	3	8000
PRC32D.Z	3200/500	310-1070	1150	900	415	775	14	5,5	177	96	327	392	3	8250

★ Suggested selection
We recommend forks with reinforced lower brackets.

Advantages

- Improves productivity
- 360° rotation
- Designed for the fishing industry

Available on request

- Different fork bar lengths
- Third fork hook to weld on the fork for greater stability
- Rotator forks with reinforced lower bracket

Box rotator 360°

PRC-DA

1000 kg
4000 kg

Product info

- 360° rotation
- Continuous rotation in both directions
- Fast rotation and high torque
- Excellent visibility through the plates
- Excellent fork mounting system with additional robust design
- W6 – Minimum carriage width
- Fork bar assembly and locking fork pads included
- Adjustable arm
- Without sideshifter

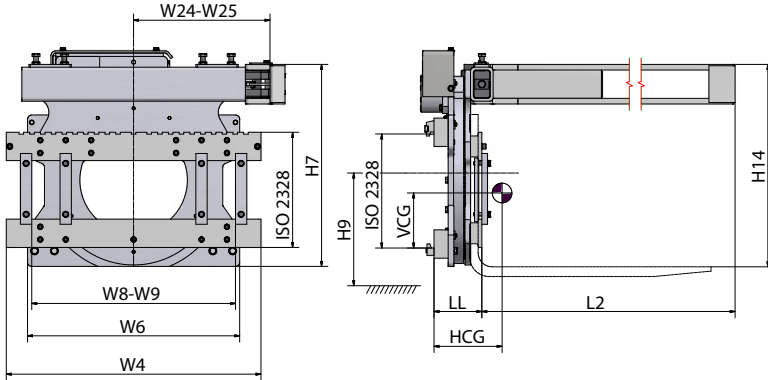

Model	Capacity	W8-W9	W4	W6	W24-W25	H14	L2	H9	H7	Rotating torque	Rotation speed - 45 l/min* - 60 l/min	LL	HCG	VCG	Weight	ISO 2328	RRP
																	Euro
	kg/mm	mm	mm	mm		mm	mm			kNm/ 160 bar	rpm	mm	mm	mm	kg		
PRC8DA	1000/500	200-845	900	680	480-700	687	1270	315	740	7,2	8,3*	163	152	363	295	2	6260
PRC18DA	1800/500	200-845	900	680	480-700	687	1270	315	740	7,2	8,3*	163	152	363	296	2	6260
★ PRC22DA	2200/500	200-1000	1050	680	580-800	687	1270	315	740	7,2	8,3*	163	152	366	312	2	6260
PRC28DA	2800/500	310-1070	1150	940	580-800	800	1270	415	805	11	6,9	170	137	403	420	3	7750
★ PRC32DA	3200/500	310-1070	1150	940	580-800	800	1270	415	805	14	5,5	171	140	404	419	3	7750
PRC40DA	4000/500	330-1220	1300	1080	580-800	800	1270	420	840	16	4,8	187	141	392	519	3	10600

★ Suggested selection
We recommend forklifts with reinforced lower brackets.

Options

	RRP
	Euro
Foundry kit (front and back cover) FEM 2 and 3	1050

Available on request

- Different fork bar lengths
- 180° rotation kit
- Fishing industry version
- Rotator forks with reinforced lower bracket

RBC

2050 kg
3600 kg

Rotator with hydraulic bin retainer 360°

Product info

- 360° rotation
- Continuous rotation in both directions
- Fast rotation and high torque
- Excellent fork mounting system with additional robust design
- W6 – Minimum carriage width
- H39–H40 bin height (minimum/maximum)
- Fork bar assembly and locking fork pads included
- Without forks
- Without sideshifter

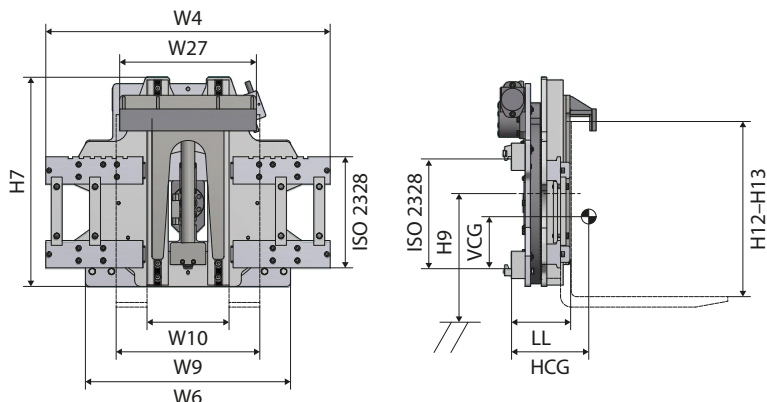

Model	Capacity	W9	W4	W6	H12–H13	H39–H40	H9	W27	H7	W10	Rotating torque	Rotation speed –45 l/min* –60 l/min	LL	HCG	VCG	Weight	ISO 2328	RRP
		kg/mm	mm	mm	mm	mm	mm	mm	mm	mm			mm	mm	mm		mm	mm
RBC.20	2050/600	960	1040	750	590–990	620–880	415	500	835	330	7,2	8,3*	214	109	297	339	2	10680
RBC.30	3000/600	1090	1150	900	590–990	620–880	415	500	835	330	14	5,5	214	111	299	399	3	12100
RBC.36	3600/600	1090	1150	900	590–990	620–880	415	500	835	330	14	5,5	214	120	350	408	3	12400
RBC.20.01	2050/600	960	1040	750	1200–1800	1230–1690	415	500	1285	330	7,2	8,3*	214	109	400	380	2	10780

We recommend forks with reinforced lower brackets.

Options

	RRP
	Euro
Separate sideshifting 100 +100 for ISO/FEM 2	1330
Separate sideshifting 100 +100 for ISO/FEM 3	1800

Available on request

- Different fork bar lengths
- 180° rotation kit
- Version for fishing industry
- Rotator forks with reinforced lower bracket

Advantages

- Improves productivity
- 360° rotation
- Ideal for handling hydraulic bins
- Expertly manufactured
- High mechanical strength

Plastic container rotator 360°

RLC

1000 kg
1800 kg

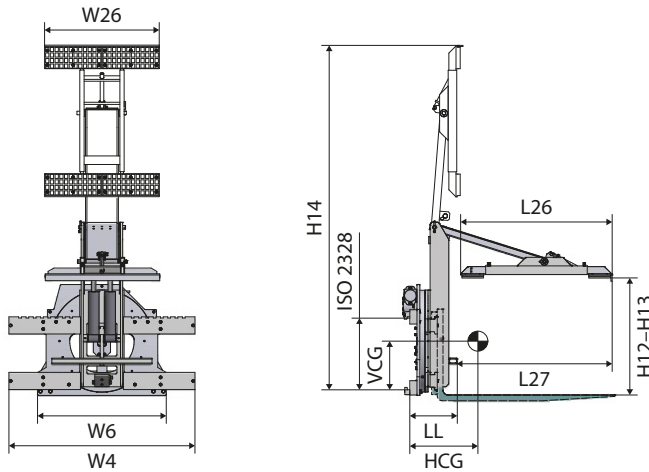

Product info

- 360° rotation
- Continuous rotation in both directions
- Fast rotation and high torque
- Excellent fork mounting system with additional robust design
- W6 – Minimum carriage width
- Without sidsifter



Model	Capacity	W4	W6	L26	W26	L27	H14	H12-H13	LL	HCG	VCG	Weight	ISO 2328	RRP
	kg/mm													mm
RLC10	1000/600	900	750	1320	760	1350	2450	340-705	319	259	344	411	2	12330
RLC18	1800/600	1300	900	1320	800	1350	2400	800-1050	332	234	459	524	3	15800

We recommend forks with reinforced lower brackets.

Advantages

- Improves productivity
- 360° rotation
- Ideal for handling plastic containers
- Expertly manufactured
- Superior mechanical strength

Available on request

- Separate sidsifter: 100 + 100 mm
- Split contact pad models
- Rotator forks with reinforced lower bracket

RLW**2500 kg
3500 kg**

Box rotator 180°

Product info

- Technical data without forks
- Without sideshifter

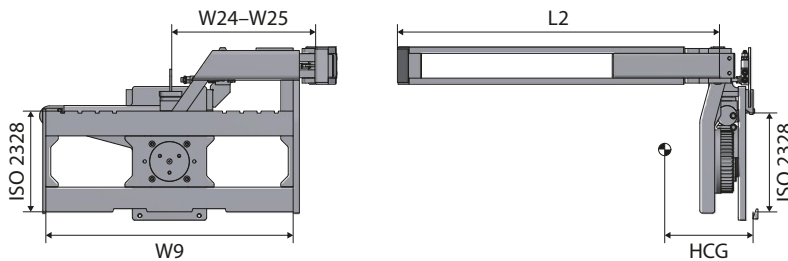

Model	Capacity	W9	W24-W25	L2	HCG	Weight	ISO 2328	RRP
	kg/mm							mm
Type RLW								
RLW25.02	2500/500	1000	560-800	1240	-	270	2	4450
RLW35.01	3500/500	1200	680-900	1240	-	345	3	5200
Type RLW-R								
RLW25.02.R	2500/500	1000	560-800	1240	158	270	2	5620
RLW35.01.R	3500/500	1200	680-900	1240	158	345	3	6500

We recommend forks with reinforced lower brackets.

Advantages

- Improves productivity
- High-quality threaded tipping shaft with adjustable ball bearing
- The open design ensures optimum visibility
- Folding third arm (operated by a gas spring) with adjustable width
- Rotator forks with reinforced lower bracket

Type RLW (adjustable left arm)



Type RLW-R (adjustable right arm)



Box rotator 180°

RLW

2500 kg
3500 kg

Product info

- Technical data without forks
- With integrated sideshifting
- Total sideshifter stroke: 100 + 100 mm

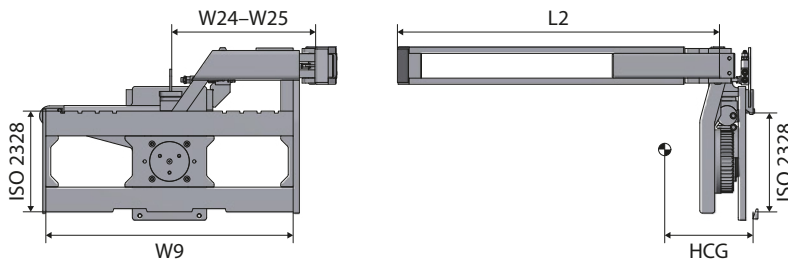

Model	Capacity	W9	W24-W25	L2	HCG	Weight	ISO 2328	RRP
	kg/mm							Euro
Type RLW-ES								
RLW25.02.E.S	2500/500	1000	560-800	1240	141	335	2	7930
RLW35.01.E.S	3500/500	1200	680-900	1240	145	405	3	9130

We recommend forks with reinforced lower brackets.

Advantages

- Improves productivity
- 360° rotation

Available on request

- Rotator forks with reinforced lower bracket

Type RLW-ES (adjustable left arm)



RLC-A

1000 kg

Plastic container rotator 150° for agriculture

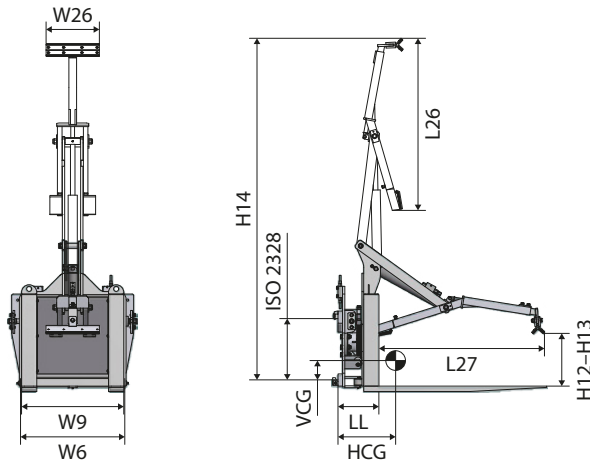

Product info

- W6 – Minimum carriage width
- With forks: 1200 mm length
- With quick-release mountings
- Without sideshifter



Model	Capacity	W9	W6	L26	W26	L27	H14	H12-H13	LL	HCG	VCG	Weight	ISO 2328	RRP
	kg/mm													mm
RLC10A	1000/500	670	700	1200	350	1250	2400	580-780	270	300	265	285	2A	6500

Advantages

- Improves productivity
- Ideal for handling plastic containers

Available on request

- Rotator forks with reinforced lower bracket

Technical data

Box rotators

Model	Rotating						Sideshifting						Hydraulic functions
	Operating pressure			Oil flow rate			Operating pressure			Oil flow rate			
	Min.	Recommended	Max.	Min.	Recommended	Max.	Min.	Recommended	Max.	Min.	Recommended	Max.	
PRC8D – PRC22D	120	160	180	20	30	40	–	–	–	–	–	–	1
PRC28D – PRC45D	120	160	180	20	35	45	–	–	–	–	–	–	1
PRC55D – PRC80D	120	160	180	25	40	65	–	–	–	–	–	–	1
PRC8DT – PRC22DT	120	160	180	20	30	40	120	160	180	10	15	25	2
PRC28DT – PRC45DT	120	160	180	20	35	45	120	160	180	10	20	30	2
PRC55DT – PRC80DT	120	160	180	25	40	65	120	160	180	10	25	35	2
PRC8Z – PRC22Z	120	160	180	20	30	40	–	–	–	–	–	–	1
PRC28Z – PRC32Z	120	160	180	20	35	45	–	–	–	–	–	–	1
PRC8DA – PRC22DA	120	160	180	20	30	40	–	–	–	–	–	–	1
PRC28DA – PRC40DA	120	160	180	20	35	45	–	–	–	–	–	–	1
RBC	120	160	180	20	30	40	–	–	–	–	–	–	2
RLC	120	160	180	20	25	35	–	–	–	–	–	–	1
RLW	–	–	220	–	–	–	–	–	–	–	–	–	1
RLW-R	–	–	220	–	–	–	–	–	–	–	–	–	1
RLW-ES	–	–	220	–	–	–	–	–	–	–	–	–	2





5. Roll clamps

Our range includes several types of roll clamps, the most common of which are paper roll clamps. These clamps allow operators to handle paper rolls regardless of their diameter, weight or type of paper. We also have tyre clamps in our range.

CR

500 kg
2200 kg

Rotating paper roll clamp 360°

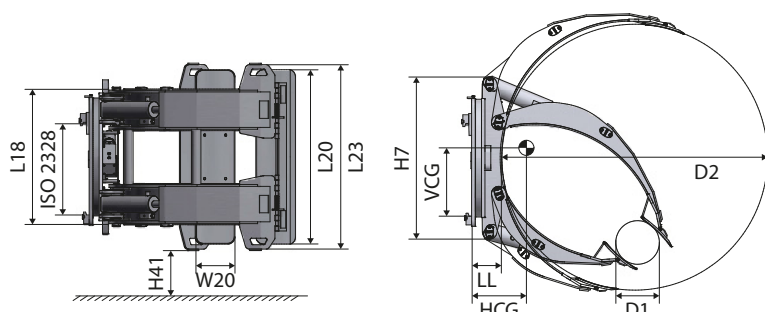

Product info

- 360° rotation system
- Anti-shock retaining valve on each cylinder
- Thinner arm profile and maximised clamping strenght transferred to the contact pads
- New clamp geometry to optimise visibility through the arms
- Adjustable pressure relief valve for optimal adjustment of the strenght
- The positionable short arm allows for handling of rolls with a wide range diameters
- Mounting angle 2°
- L23 – Contact pad protection structure



Model	Capacity	D1–D2	H7	L18	L20 x W20	L23	H41	LL	HCG	VCG	Weight	ISO 2328	RRP
	kg/mm												mm
CR05111	500/1100	800–2200	957	506	500 x 280	550	0	190	419	398	735	2A	15800
CR1050	1000/500	450–1000	820	390	720 x 230	750	0	203	256	341	378	2A	10950
CR10105*	1000/1050	650–2100	1300	680	1200 x 280	1070	0	190	430	409	830	3A	21510
CR1275	1200/750	250–1500	1190	736	720 x 250	770	0	190	314	430	690	2A	12320
CR1276	1200/750	450–1500	1190	736	720 x 250	770	0	190	314	430	676	2A	12100
CR1280	1200/800	250–1520	1190	736	720 x 250	770	0	190	313	467	676	2A	12980
CR1281	1200/800	450–1520	1190	736	720 x 250	770	0	190	313	467	663	2A	12500
CR1290*	1200/925	450–1850	1120	730	820 x 250	870	0	212	368	337	788	2A	15000
CR1291	1200/925	250–1850	1120	730	820 x 250	870	0	212	368	337	775	2A	15070
CR1265*	1200/650	250–1300	916	486	720 x 250	770	0	250	320	309	550	2A	11900
CR1266	1200/650	450–1300	916	486	720 x 250	770	0	250	320	309	537	2A	11270
CR1357	1300/575	300–1150	785	330	720 x 200	770	0	205	270	288	405	2A	10930
CR1355*	1300/550	250–1100	907	690	720 x 230	750	0	205	260	307	509	2A	11150
CR1655*	1600/550	250–1100	890	690	820 x 250	870	0	250	268	308	515	2A	14940
CR1656	1600/550	450–1100	890	690	820 x 250	870	0	250	268	308	505	2A	14500
CR1665*	1600/650	250–1300	916	486	820 x 250	870	0	250	327	302	570	2A	16330
CR1666	1600/650	450–1300	916	486	820 x 250	870	0	250	330	312	550	2A	15380
CR1680*	1600/800	250–1600	1190	846	820 x 250	870	0	175	305	392	670	3A	17690
CR1681	1600/800	500–1600	1190	846	820 x 250	870	0	175	305	392	683	3A	16860
CR1682	1600/800	500–1600	1189	486	650 x 250	680	78	205	337	435	608	3A	16720
CR1865*	1800/650	250–1300	900	850	820 x 250	870	0	175	322	300	555	2A	16950
CR1866	1800/650	500–1300	900	850	820 x 250	870	0	175	322	300	545	2A	15980
CR2080*	2000/800	200–1600	1035	880	1000 x 250	1034	0	195	551	303	775	3A	19910
CR2070*	2000/700	250–1400	916	852	820 x 250	870	0	190	284	341	724	3A	18730
CR2071	2000/700	500–1400	916	852	820 x 250	870	0	190	284	341	705	3A	17870
CR2081	2000/800	450–1600	1035	880	1000 x 250	1034	0	195	551	303	755	3A	18970
CR2265*	2200/650	280–1300	916	852	820 x 250	870	0	194	283	320	700	2A	17100
CR2266	2200/650	500–1300	916	852	820 x 250	870	0	194	283	320	685	2A	15890

* Positionable short arm

Rotating paper roll clamp 360°

CR

2300 kg
3200 kg

Product info

- 360° rotation system
- Anti-shock retaining valve on each cylinder
- Thinner arm profile and maximised clamping strenght transferred to the contact pads
- New clamp geometry to optimise visibility through the arms
- Adjustable pressure relief valve for optimal adjustment of the strenght
- The positionable short arm allows for handling of rolls with a wide rande diameters
- Mounting angle 2°
- L23 – Contact pad protection structure

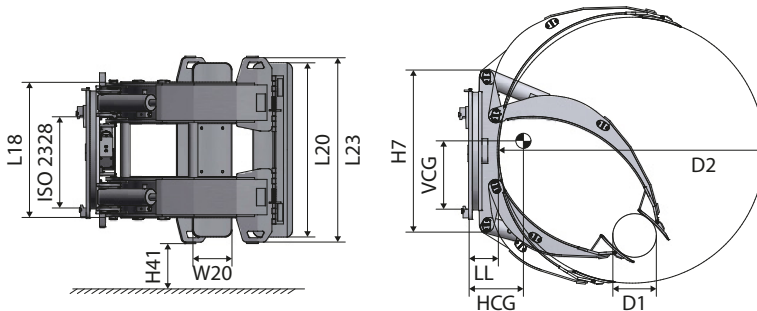

Model	Capacity	D1–D2	H7	L18	L20 x W20	L23	H41	LL	HCG	VCG	Weight	ISO 2328	RRP
	kg/mm												mm
CR2390*	2300/900	300–1830	1100	934	1020 x 250	1070	0	200	370	474	1030	3A	25780
CR2391	2300/900	550–1830	1100	934	1020 x 250	1070	0	200	369	474	1020	3A	24770
CR2565*	2500/650	280–1300	916	852	1020 x 250	1070	0	199	308	342	749	3A	18660
CR2566	2500/650	500–1300	916	852	1020 x 250	1070	0	199	308	342	738	3A	17890
CR2580*	2500/800	250–1600	928	934	1020 x 250	1070	0	200	321	446	988	3A	23540
CR2581	2500/800	500–1600	928	934	1020 x 250	1070	0	200	321	446	969	3A	22390
CR2590*	2500/900	300–1830	1100	934	1020 x 250	1070	0	200	370	465	1070	3A	26500
CR2591	2500/900	550–1830	1100	934	1020 x 250	1070	0	200	369	468	1060	3A	25490
CR25105*	2500/1050	550–2100	1400	1050	1600 x 350	1650	0	210	530	643	1400	4A	29000
CR25125T	2500/1250	660–2500	1500	1041	1600 x 400	1650	0	246	450	430	1750	4A	On request
CR2790*	2700/900	300–1830	1116	934	1200 x 280	1270	0	210	357	468	1108	4A	28140
CR2791	2700/900	550–1830	1116	934	1200 x 280	1270	0	210	357	468	1093	4A	27120
CR2880*	2800/800	250–1600	928	934	1020 x 250	1070	0	200	340	440	940	3A	24420
CR2881	2800/800	500–1600	928	934	1020 x 250	1070	0	200	342	443	930	3A	23410
CR3065*	3000/650	250–1300	928	934	1020 x 250	1070	0	200	269	415	887	3A	21820
CR3066	3000/650	450–1300	928	934	1020 x 250	1070	0	200	269	415	882	3A	20770
CR3070*	3000/700	250–1400	928	934	1020 x 250	1070	0	200	290	444	928	3A	22000
CR3071	3000/700	550–1400	928	934	1020 x 250	1070	0	200	290	444	920	3A	20990
CR3075*	3000/750	250–1520	928	934	1020 x 250	1070	0	200	263	431	945	3A	23380
CR3076	3000/750	500–1520	928	934	1020 x 250	1070	0	200	263	431	930	3A	22430
CR3090*	3000/900	300–1830	1115	920	1200 x 280	1270	0	209	363	479	1137	4A	25130
CR3091	3000/900	550–1830	1115	920	1200 x 280	1270	0	209	363	479	1122	4A	24290
CR30120T*	3000/1200	660–2400	1560	1041	1800 x 400	1250	0	255	487	551	1890	4A	On request
CR30121T	3000/1200	1000–2400	1560	1041	1800 x 400	1250	0	255	487	551	1910	4A	On request
CR30130T	3000/1300	660–2600	1560	1050	1800 x 400	1650	0	249	512	543	2010	4A	On request
CR3280*	3200/800	250–1600	1100	1041	1200 x 280	1250	0	228	329	502	1204	4A	23730
CR3281	3200/800	500–1600	1100	1041	1200 x 280	1250	0	228	329	502	1189	4A	23460

* Positionable short arm

CR

3300 kg
4500 kg

Rotating paper roll clamp 360°

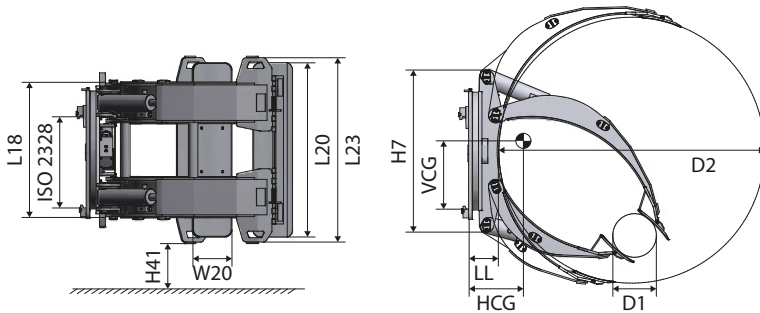

Product info

- 360° rotation system
- Anti-shock retaining valve on each cylinder
- Thinner arm profile and maximised clamping strenght transferred to the contact pads
- New clamp geometry to optimise visibility through the arms
- Adjustable pressure relief valve for optimal adjustment of the strenght
- The positionable short arm allows for handling of rolls with a wide rande diameters
- Mounting angle 2°
- L23 – Contact pad protection structure



Model	Capacity	D1–D2	H7	L18	L20 x W20	L23	H41	LL	HCG	VCG	Weight	ISO 2328	RRP
	kg/mm												mm
CR3370*	3300/700	250–1400	1050	1041	1200 x 280	1250	0	205	292	447	985	3A	23190
CR3371	3300/700	500–1400	1050	1041	1200 x 280	1250	0	205	293	446	975	3A	22090
CR3375*	3300/750	250–1520	1100	1041	1200 x 280	1250	0	215	292	447	995	3A	23540
CR3376	3300/750	500–1520	1100	1041	1200 x 280	1250	0	215	293	446	985	3A	22430
CR33100*	3300/1100	450–2000	1400	1043	1200 x 280	1240	0	210	401	500	1512	4A	33000
CR3490*	3400/900	550–1830	1200	1041	1200 x 280	1250	0	230	380	526	1440	4A	30720
CR3491	3400/900	660–1830	1200	1041	1200 x 280	1250	0	230	380	526	1425	4A	29890
CR3566	3500/650	500–1300	1100	1041	1200 x 280	1250	0	220	305	465	1050	3A	21120
CR3580*	3500/800	250–1600	1100	1041	1200 x 280	1250	0	241	366	517	1268	4A	24300
CR3581	3500/800	500–1600	1100	1041	1200 x 280	1250	0	241	366	517	1253	4A	23750
CR3890*	3800/900	550–1830	1100	1041	1200 x 280	1250	0	230	388	515	1460	4A	27500
CR38130T	3800/1300	850–2600	1560	1041	1800 x 450	-	0	282	500	565	2225	4A	On request
CR4080*	4000/800	250–1600	1100	1041	1200 x 280	1250	0	215	338	317	1235	4A	27390
CR4081	4000/800	500–1600	1100	1041	1200 x 280	1250	0	215	339	318	1225	4A	26090
CR4275*	4200/750	250–1520	1100	1041	1200 x 280	1250	0	240	340	526	1229	4A	27390
CR4276	4200/750	500–1520	1100	1041	1200 x 280	1250	0	240	340	526	1214	4A	26090
CR4565*	4500/650	250–1300	1100	1041	1200 x 280	1250	0	220	328	513	1260	4A	27130
CR4566	4500/650	500–1300	1100	1041	1200 x 280	1250	0	220	329	513	1250	4A	26100

* Positionable short arm

Available on request

- Different pad covers (black rubber, yellow non-marking rubber, plain steel, etc.).
- Various contact pads
- Models for tissue paper
- 180° rotation kit
- Different roll range

See this attachment in action



Rotating paper roll clamp – split arms 360°

CR-S

1200 kg
2800 kg

Product info

- 360° rotation system
- The split long arm allows for simultaneous handling of two paper rolls with different diameters
- Anti-shock retaining valve on each cylinder
- Thinner arm profile and maximised clamping strength transferred to the contact pads
- New clamp geometry to optimise visibility through the arms
- Adjustable pressure relief valve for optimal adjustment of the strength
- The positionable short arm allows for handling of rolls with a wide range of diameters
- Mounting angle 2°
- L23 – Contact pad protection structure

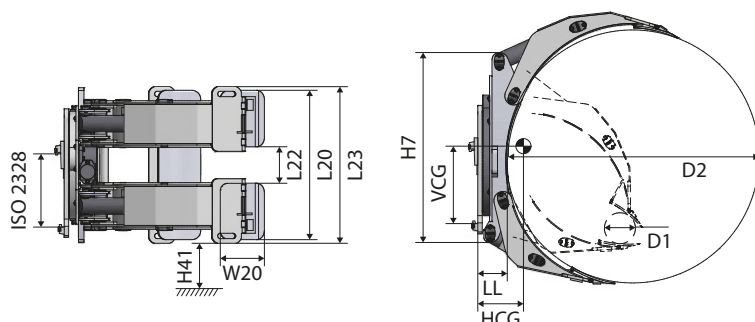

Model	Capacity	D1–D2	H7	L18	L20 x W20	L22	L23	H41	LL	HCG	VCG	Weight	ISO 2328	RRP
	kg/mm													mm
CR1290.S*	1200/925	450–1850	1120	730	820 x 250	200	870	0	212	368	337	745	2A	19020
CR1665.S*	1600/650	250–1300	1043	706	820 x 250	200	860	0	179	269	341	568	2A	15600
CR1666.S	1600/650	500–1300	1043	706	820 x 250	200	860	0	179	269	341	564	2A	14870
CR1680.S*	1600/800	250–1600	1190	846	820 x 250	200	870	0	175	278	381	683	3A	18400
CR1681.S	1600/800	500–1600	1190	846	820 x 250	200	870	0	175	278	381	676	3A	17230
CR1865.S*	1800/650	250–1300	900	850	820 x 250	200	870	0	175	322	300	535	2A	16460
CR1866.S	1800/650	500–1300	900	850	820 x 250	200	870	0	175	322	300	525	2A	15590
CR2070.S*	2000/700	250–1400	916	852	820 x 250	200	870	0	190	284	341	705	3A	18530
CR2071.S	2000/700	500–1400	916	852	820 x 250	200	870	0	190	284	341	693	3A	17650
CR2080.S*	2000/800	200–1600	1035	880	1020 x 250	200	1034	0	195	551	303	736	3A	19940
CR2081.S	2000/800	500–1600	1035	880	1020 x 250	200	1034	0	195	551	303	724	3A	19020
CR2265.S*	2200/650	280–1300	916	852	820 x 250	200	870	0	194	283	320	695	2A	16550
CR2266.S	2200/650	500–1350	916	852	820 x 250	200	870	0	194	283	320	680	2A	15600
CR2390.S*	2300/900	300–1830	1100	934	1020 x 250	200	1070	0	200	370	474	1010	3A	24360
CR2391.S	2300/900	550–1830	1100	934	1020 x 250	200	1070	0	200	369	474	1000	3A	24240
CR2565.S*	2500/650	280–1300	916	852	1020 x 250	200	1070	0	199	308	342	726	3A	17910
CR2566.S	2500/650	500–1300	916	852	1020 x 250	200	1070	0	199	308	342	714	3A	17220
CR2590.S*	2500/900	300–1830	1100	934	1020 x 250	200	1070	0	200	370	465	1050	3A	24560
CR2591.S	2500/900	550–1830	1100	934	1020 x 250	200	1070	0	200	369	468	1040	3A	24230
CR2580.S*	2500/800	250–1600	900	934	1020 x 250	200	1070	0	200	313	426	973	3A	22530
CR2581.S	2500/800	500–1600	900	934	1020 x 250	200	1070	0	200	313	426	958	3A	22310
CR25105.S*	2500/1050	550–2100	1400	1050	1600 x 350	200	1650	0	210	530	643	1380	4A	26910
CR2790.S*	2700/900	300–1830	1116	934	1200 x 280	200	1270	0	210	357	468	1118	4A	26480
CR2791.S	2700/900	550–1830	1116	934	1200 x 280	200	1270	0	210	357	468	1103	4A	26360
CR2880.S*	2800/800	250–1600	900	934	1020 x 250	200	1070	0	200	340	440	920	3A	23350
CR2881.S	2800/800	500–1600	900	934	1020 x 250	200	1070	0	200	342	443	910	3A	23060

* Positionable short arm

CR-S

3000 kg
3300 kg

Rotating paper roll clamp – split arms 360°

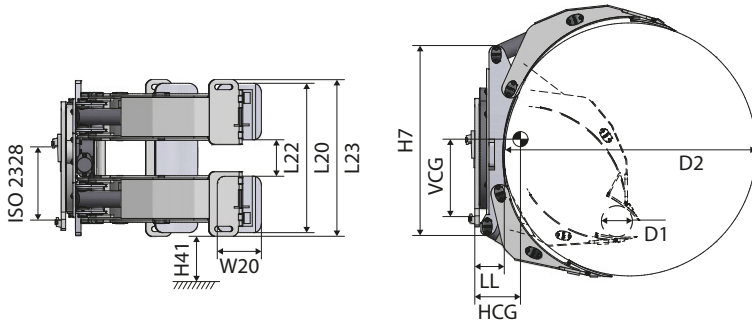

Product info

- 360° rotation system
- The split long arm allows for simultaneous handling of two paper rolls with different diameters
- Anti-shock retaining valve on each cylinder
- Thinner arm profile and maximised clamping strength transferred to the contact pads
- New clamp geometry to optimise visibility through the arms
- Adjustable pressure relief valve for optimal adjustment of the strength
- The positionable short arm allows for handling of rolls with a wide range of diameters
- Mounting angle 2°
- L23 – Contact pad protection structure



Model	Capacity	D1–D2	H7	L18	L20 x W20	L22	L23	H41	LL	HCG	VCG	Weight	ISO 2328	RRP
	kg/mm													mm
CR3066.S	3000/650	500–1300	928	934	1020 x 250	200	1070	0	200	269	415	869	3A	20750
CR3070.S*	3000/700	250–1400	928	934	1020 x 250	200	1070	0	200	290	444	885	3A	21200
CR3071.S	3000/700	500–1400	928	934	1020 x 250	200	1070	0	200	290	444	875	3A	20880
CR3090.S*	3000/900	300–1830	1115	1041	1200 x 280	200	1270	0	209	363	479	1117	4A	24260
CR3091.S	3000/900	550–1830	1115	1041	1200 x 280	200	1270	0	209	363	479	1102	4A	23980
CR3075.S*	3000/750	250–1520	900	934	1020 x 250	200	1070	0	200	292	447	900	3A	22480
CR3076.S	3000/750	500–1520	900	934	1020 x 250	200	1070	0	200	293	446	890	3A	22260
CR3280.S*	3200/800	250–1600	1100	1041	1200 x 280	200	1250	0	228	329	502	1199	4A	22800
CR3281.S	3200/800	500–1600	1100	1041	1200 x 280	200	1250	0	228	329	502	1184	4A	22710
CR3370.S*	3300/700	250–1400	1050	1041	1200 x 280	200	1250	0	205	292	447	965	3A	22330
CR3371.S	3300/700	500–1400	1050	1041	1200 x 280	200	1250	0	205	293	446	955	3A	21920
CR3375.S*	3300/750	250–1520	1100	1041	1200 x 280	200	1250	0	215	292	447	975	3A	22640
CR3065.S*	3000/650	250–1300	928	934	1020 x 250	200	1070	0	200	269	415	874	3A	21030
CR3376.S	3300/750	500–1520	1100	1041	1200 x 280	200	1250	0	215	293	446	965	3A	22240
CR33100.S*	3300/1000	450–2000	1400	1043	1200 x 280	200	1240	0	210	401	500	1480	4A	31760

* Positionable short arm

Available on request

- Different pad covers (black rubber, yellow non-marking rubber, plain steel, etc.).
- Various contact pads
- Models for tissue paper
- 180° rotation kit
- Open control valve V152.12.KIT.C (see page 273)
- Different roll range

Rotating paper roll clamp – split arms 360°

CR-S

3400 kg
4500 kg

Product info

- 360° rotation system
- The split long arm allows for simultaneous handling of two paper rolls with different diameters
- Anti-shock retaining valve on each cylinder
- Thinner arm profile and maximised clamping strength transferred to the contact pads
- New clamp geometry to optimise visibility through the arms
- Adjustable pressure relief valve for optimal adjustment of the strength
- The positionable short arm allows for handling of rolls with a wide range of diameters
- Mounting angle 2°
- L23 – Contact pad protection structure

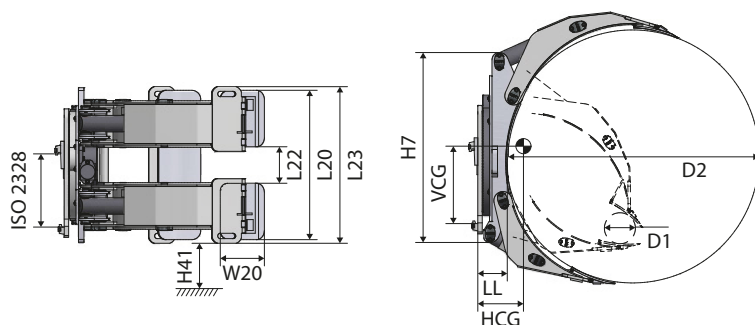

Model	Capacity	D1–D2	H7	L18	L20 x W20	L22	L23	H41	LL	HCG	VCG	Weight	ISO 2328	RRP
	kg/mm													mm
CR3490.S*	3400/900	550–1830	1200	1041	1200 x 280	200	1250	0	230	397	533	1400	4A	29120
CR3491.S	3400/900	660–1830	1200	1041	1200 x 280	200	1250	0	230	398	534	1385	4A	28940
CR3565.S*	3500/650	250–1300	1100	1041	1200 x 280	200	1250	0	220	305	465	1030	3A	21360
CR3566.S	3500/650	500–1300	1100	1041	1200 x 280	200	1250	0	220	305	465	1030	3A	20990
CR3580.S*	3500/800	250–1600	1100	1041	1200 x 280	200	1250	0	241	366	517	1228	4A	25800
CR3581.S	3500/800	500–1600	1100	1041	1200 x 280	200	1250	0	241	366	517	1213	4A	25400
CR3890.S*	3800/900	550–1830	1100	1041	1200 x 280	200	1250	0	230	388	515	1440	4A	30060
CR4080.S*	4000/800	250–1600	1100	1041	1200 x 280	200	1250	0	215	338	317	1215	4A	26140
CR4081.S	4000/800	500–1600	1100	1041	1200 x 280	200	1250	0	215	339	318	1205	4A	26010
CR4275.S*	4200/750	250–1520	1100	1041	1200 x 280	200	1250	0	240	336	449	1220	4A	26140
CR4276.S	4200/750	500–1520	1100	1041	1200 x 280	200	1250	0	240	340	526	1193	4A	25790
CR4565.S*	4500/650	250–1300	1100	1041	1200 x 280	200	1250	0	220	328	513	1240	4A	26400
CR4566.S	4500/650	500–1300	1100	1041	1200 x 280	200	1250	0	220	320	513	1230	4A	26060

* Positionable short arm

Available on request

- Different pad covers (black rubber, yellow non-marking rubber, plain steel, etc.).
- Various contact pads
- Models for tissue paper
- 180° rotation kit
- Open control valve V152.12.KIT.C (see page 273)
- Different roll range

CR-TY**500 kg
1600 kg**

Rotating tyre clamp 360°

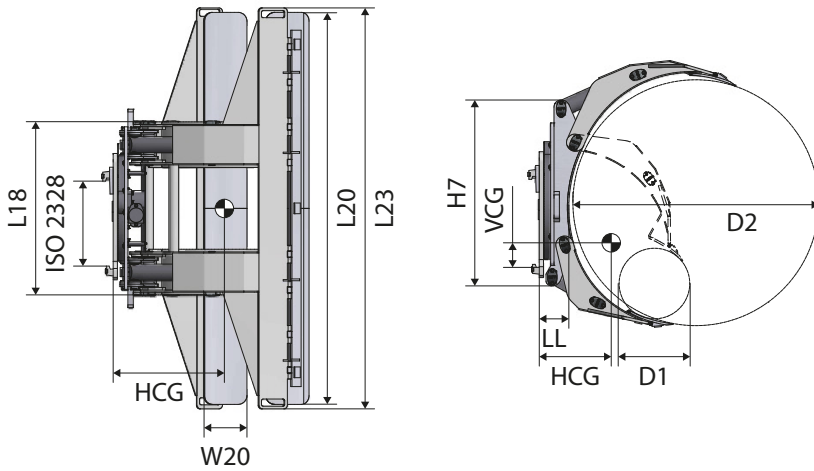

Product info

- 360° rotation system
- Anti-shock retaining valve on each cylinder
- Thinner arm profile and maximised clamping strength transferred to the contact pads
- New clamp geometry to optimise visibility through the arms
- Adjustable pressure relief valve for optimal adjustment of the strength
- Suitable for handling tires
- Mounting angle 2°
- L23 – Contact pad protection structure



Model	Capacity	D1–D2	H7	L18	L20 x W20	L23	LL	HCG	VCG	Weight	ISO 2328	RRP
	kg/mm											mm
CR05111TY	500/1100	800–2200	957	506	500 x 280	550	190	419	398	735	2A	19230
CR1265TY*	1200/650	250–1300	1045	706	1800 x 250	1850	175	367	442	707	2A	17740
CR1266TY	1200/650	450–1300	1045	706	1800 x 250	1850	175	367	442	697	2A	17630
CR1280TY*	1200/800	250–1600	1191	736	1800 x 250	1850	175	384	459	810	2A	20670
CR1281TY	1200/800	450–1600	1191	736	1800 x 250	1850	175	384	459	800	2A	20410
CR1290TY*	1200/925	450–1850	1116	730	1200 x 250	1230	202	356	334	860	2A	22510
CR1665TY*	1600/650	250–1600	1043	971	2200 x 250	2250	180	359	436	820	2A	23060
CR1666TY	1600/650	450–1300	1043	971	2200 x 250	2250	180	359	436	810	2A	22970

* Positionable short arm

Advantages

- Expertly manufactured
- Superior mechanical strength

Available on request

- Different contact pads
- Different pad covers (black rubber, yellow non-marking rubber, plain steel, etc.).
- 180° rotation kit
- Different roll range

Tilting paper roll clamp 90°

CT

1600 kg
3500 kg

Product info

- 90° Tilting clamp for horizontal and vertical handling of rolls
- Tilting system with check valve
- Anti-shock retaining valve on each cylinder
- Thinner arm profile and maximised clamping strenght transferred to the contact pads
- New clamp geometry to optimise visibility through the arms
- Adjustable pressure relief valve for optimal adjustment of the strenght

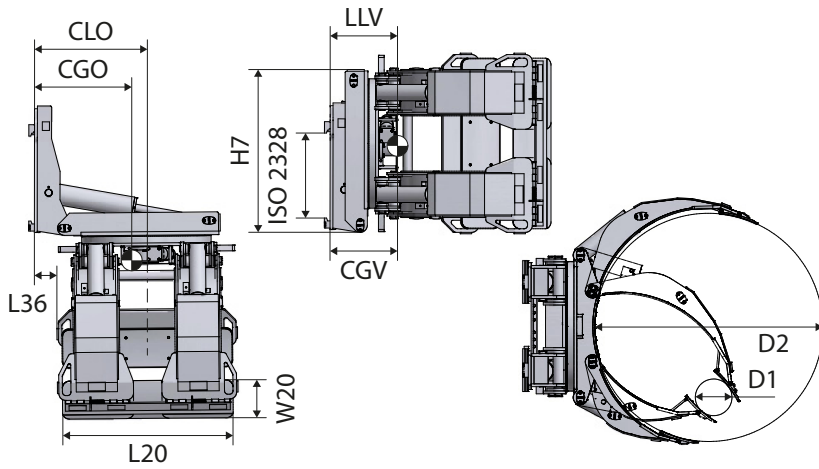

Model	Capacity	D1-D2	H7	L20 x W20	Tilt force	L36	CLO	CGO	LLV	CGV	VCG	Weight	ISO 2328	RRP
	kg/mm													mm
CT1665*	1600/650	250-1300	850	1020 x 250	16	160	660	580	254	315	**	615	2A	19780
CT1666	1600/650	450-1300	850	1020 x 250	16	160	660	580	254	315	**	610	2A	19180
CT2065*	2000/650	250-1300	850	1020 x 250	20	180	680	590	255	310	**	685	2A	18250
CT2066	2000/650	450-1300	850	1020 x 250	20	180	680	590	255	310	**	680	2A	17460
CT2565*	2500/650	250-1300	980	1100 x 250	25	160	700	590	260	335	**	780	3A	21150
CT2566	2500/650	450-1300	980	1100 x 250	25	160	700	590	260	335	**	775	3A	20460
CT2380*	2500/800	250-1600	1000	1100 x 250	27,5	180	730	605	256	370	**	835	3A	21640
CT3065*	3000/650	250-1300	1050	1200 x 250	36	200	760	640	290	330	**	920	4A	24950
CT3081	3000/800	450-1600	1200	1200 x 280	36	200	760	690	290	330	**	1040	4A	24960
CT3580*	3500/800	250-1600	1200	1200 x 280	42	180	780	700	320	390	**	1170	4A	28080

* Positionable short arm

** Consult your CAM attachments sales advisor about this specification

Available on request

- Different contact pads
- Different pad covers (black rubber, yellow non-marking rubber, plain steel, etc.).
- Models for tissue paper
- Different roll range

CT-S**1600 kg
3000 kg**

Tilting paper roll clamp – split arm 90°

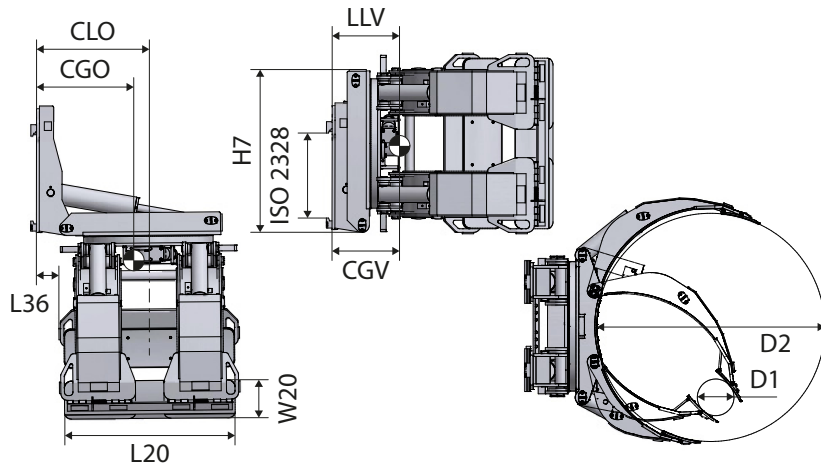
**Product info**

- 90° Tilting clamp for horizontal and vertical handling of rolls
- Tilting system with check valve
- Anti-shock retaining valve on each cylinder
- Thinner arm profile and maximised clamping strength transferred to the contact pads
- New clamp geometry to optimise visibility through the arms
- Adjustable pressure relief valve for optimal adjustment of the strength
- The split long arm allows for simultaneous handling of two paper rolls with different diameters



Model	Capacity	D1–D2	H7	L20 x W20	Tilt force	L36	CLO	CGO	LLV	CGV	VCG	Weight	ISO 2328	RRP
	kg/mm													mm
CT1665S*	1600/650	250–1300	850	1020 x 250	16	150	660	580	254	315	**	615	2A	19780
CT1666S	1600/650	450–1300	850	1020 x 250	16	150	660	580	254	315	**	610	2A	19180
CT2065S*	2000/650	250–1300	850	1020 x 250	20	140	680	590	255	310	**	685	3A	18250
CT2066S	2000/650	450–1300	850	1020 x 250	20	140	680	590	255	310	**	680	3A	17460
CT2565S*	2500/650	250–1300	980	1100 x 250	25	160	700	590	260	335	**	785	3A	21290
CT2566S	2500/650	450–1300	980	1100 x 250	25	160	700	590	260	335	**	775	3A	21020
CT3065S*	3000/650	250–1300	1050	1200 x 250	36	150	760	640	290	330	**	920	4A	22080
CT3081S	3000/800	450–1600	1200	1200 x 280	36	160	760	690	290	380	**	1040	4A	24960

* Positionable short arm

** Consult your CAM attachments sales advisor about this specification

Options

	RRP
	Euro
Independent control of one split arm	Consult your CAM attachments sales advisor for the correct price

Available on request

- Different contact pads
- Different pad covers (black rubber, yellow non-marking rubber, plain steel, etc.).
- Models for tissue paper
- Different roll range

Rotating 360° and tilting paper roll clamp 90°

CC

1200 kg
3500 kg

Product info

- 360° rotation system
- 90° Tilting clamp for horizontal and vertical handling of rolls
- Tilting system with check valve
- Anti-shock retaining valve on each cylinder
- Thinner arm profile and maximised clamping strenght transferred to the contact pads
- New clamp geometry to optimise visibility through the arms
- Adjustable pressure relief valve for optimal adjustment of the strenght
- The positionable short arm allows for handling of rolls with a wide range diameters

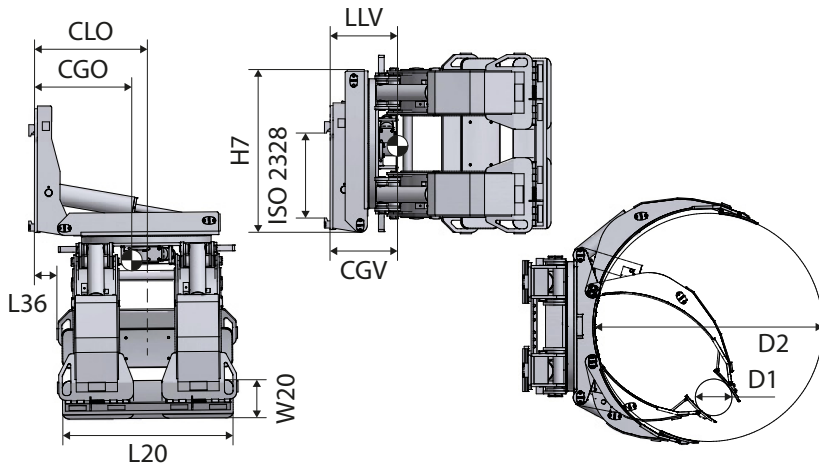

Model	Capacity	D1-D2	H7	L20 x W20	L36	CLO	CGO	LLV	CGV	VCG	Weight	ISO 2328	RRP
	kg/mm												mm
CC1265*	1200/650	250-1300	850	1000 x 250	180	680	560	320	240	**	670	2A	21550
CC1665*	1600/650	250-1300	850	1000 x 250	180	680	580	320	260	**	770	2A	24760
CC2065*	2000/650	250-1300	850	1000 x 250	180	620	620	335	340	**	860	3A	25180
CC2080*	2000/800	250-1600	980	1100 x 250	200	740	740	330	370	**	1040	3A	30450
CC2565*	2500/650	250-1300	980	1100 x 250	200	700	700	410	400	**	950	3A	25760
CC2380*	2500/800	250-1600	980	1100 x 250	200	720	720	330	390	**	1100	3A	28510
CC3065*	3000/650	250-1300	1050	1100 x 250	190	640	640	370	390	**	1100	4A	29830
CC3081	3000/800	450-1600	1050	1200 x 250	180	690	690	390	470	**	1440	4A	34560
CC3580*	3500/800	250-1600	1200	1200 x 250	165	700	700	400	500	**	1690	4A	40560

* Positionable short arm

** Consult your CAM attachments sales advisor about this specification

Available on request

- Different contact pads
- Different pad covers (black rubber, yellow non-marking rubber, plain steel, etc.).
- Models for tissue paper
- Different roll range

CPS-B

1500 kg
1800 kg

Non-rotating paper roll clamp

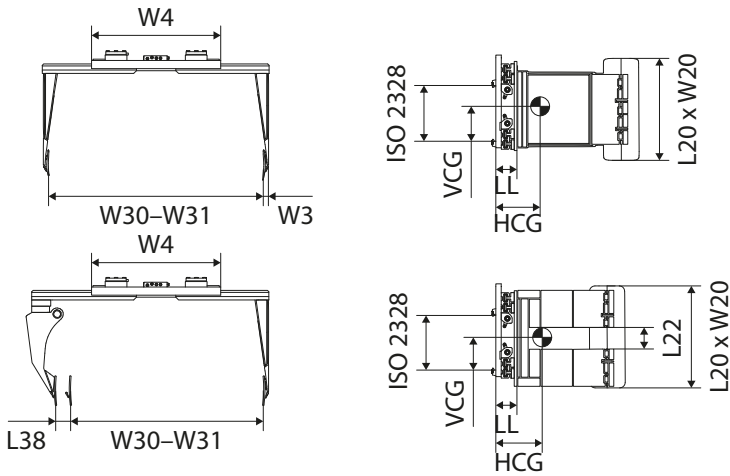

Model	Capacity	D1-D2	L20 x W20	L22	W4	W30-W31	W3	L38	LL	HCG	VCG	Weight	ISO 2328	RRP
	kg/mm													mm
PS8.B4*	4x 1500/635	850-1270	1200 x 330	200	1620	670-2720	95	80	175	270	333	1425	4A	On request
PS6.B	1x 1600/800	800-1600	865 x 330	-	1150	640-2040	35	-	130	230	292	635	3A	On request
PS8.B2	2x 1800/635	850-1270	1200 x 330	-	1620	770-2820	95	-	175	220	333	1000	4A	On request

* 2 hydraulic functions; left arm split with hydraulic compensation ± 70 mm for different diameter rollers

Options

	RRP
	Euro
Integrated sidsifter	1670

Available on request

- Pin-type mounting for PS8

Technical data

Roll clamps

Model	Rotating						Sideshifting						Hydraulic functions
	Operating pressure			Oil flow rate			Operating pressure			Oil flow rate			
	Min.	Recommended	Max.	Min.	Recommended	Max.	Min.	Recommended	Max.	Min.	Recommended	Max.	
CR05111	*	160	180	20	30	45	120	160	180	20	30	45	2
CR1050 – CR1866	*	160	180	20	30	45	120	160	180	20	30	45	2
CR1680-CR1681	*	160	180	20	30	45	120	160	180	20	30	45	2
CR2265 – CR2266	*	160	180	20	30	45	120	160	180	20	35	45	2
CR2070 – CR10105	*	160	180	20	30	45	140	160	180	20	35	45	2
CR3065 – CR3091	*	160	180	20	30	55	140	160	180	20	35	55	2
CR2790 – CR2791	*	160	180	20	30	55	140	160	180	20	35	55	2
CR3490 – CR25105	*	160	180	20	30	55	140	160	180	20	35	55	2
CR25125T	*	160	180	20	30	55	140	160	180	20	35	55	2
CR30120T – CR30121T	*	160	180	20	30	55	140	160	180	20	35	55	2
CR30130T	*	160	180	20	30	55	140	160	180	20	35	55	2
CR38130T	*	160	180	20	30	55	140	160	180	20	40	55	2
CR1665.S – CR1666.S	*	160	180	20	30	45	120	160	180	20	30	45	2
CR1865.S – CR1866.S	*	160	180	20	30	45	120	160	180	20	30	45	2
CR2265.S – CR2266.S	*	160	180	20	30	45	120	160	180	20	35	45	2
CR2070.S – CR2081.S	*	160	180	20	30	45	140	160	180	20	35	45	2
CR3065.S – CR2591.S	*	160	180	20	30	55	140	160	180	20	35	55	2
CR2790.S – CR2791.S	*	160	180	20	30	55	140	160	180	20	35	55	2
CR3070.S – CR3091.S	*	160	180	20	30	55	140	160	180	20	35	55	2
CR3490.S – CR25105.S	*	160	180	20	30	55	140	160	180	20	35	55	2
CT1665 – CT2066	*	160	180	20	30	45	–	–	–	–	–	–	2
CT2565 – CT2380	*	160	180	20	30	55	–	–	–	–	–	–	2
CT3065 – CT3580	*	160	180	20	30	55	–	–	–	–	–	–	2
CC1265 – CC2080	*	160	180	20	30	45	120	160	180	20	30	45	3
CC2565 – CC2380	*	160	180	20	30	55	140	160	180	20	35	55	3
CC3065 – CC3580	*	160	180	20	30	55	140	160	180	20	35	55	3
CT1665S – CT2066S	*	160	180	20	30	45	–	–	–	–	–	–	2
CT2565S – CT2566S	*	160	180	20	30	55	–	–	–	–	–	–	2
CT3065S – CT3081S	*	160	180	20	30	55	–	–	–	–	–	–	2
PS6.B	*	160	180	20	30	55	–	–	–	–	–	–	1
PS8.B2 – PS8.B4	*	160	180	20	30	55	–	–	–	–	–	–	1
CR05111TY	*	160	180	20	30	45	140	160	180	20	30	45	2
CR1265TY – CR1266TY	*	160	180	20	30	45	140	160	180	20	30	45	2
CR1280TY – CR1290TY	*	160	180	20	30	45	140	160	180	20	30	45	2
CR1665TY – CR1666TY	*	160	180	20	30	45	140	160	180	20	30	45	2



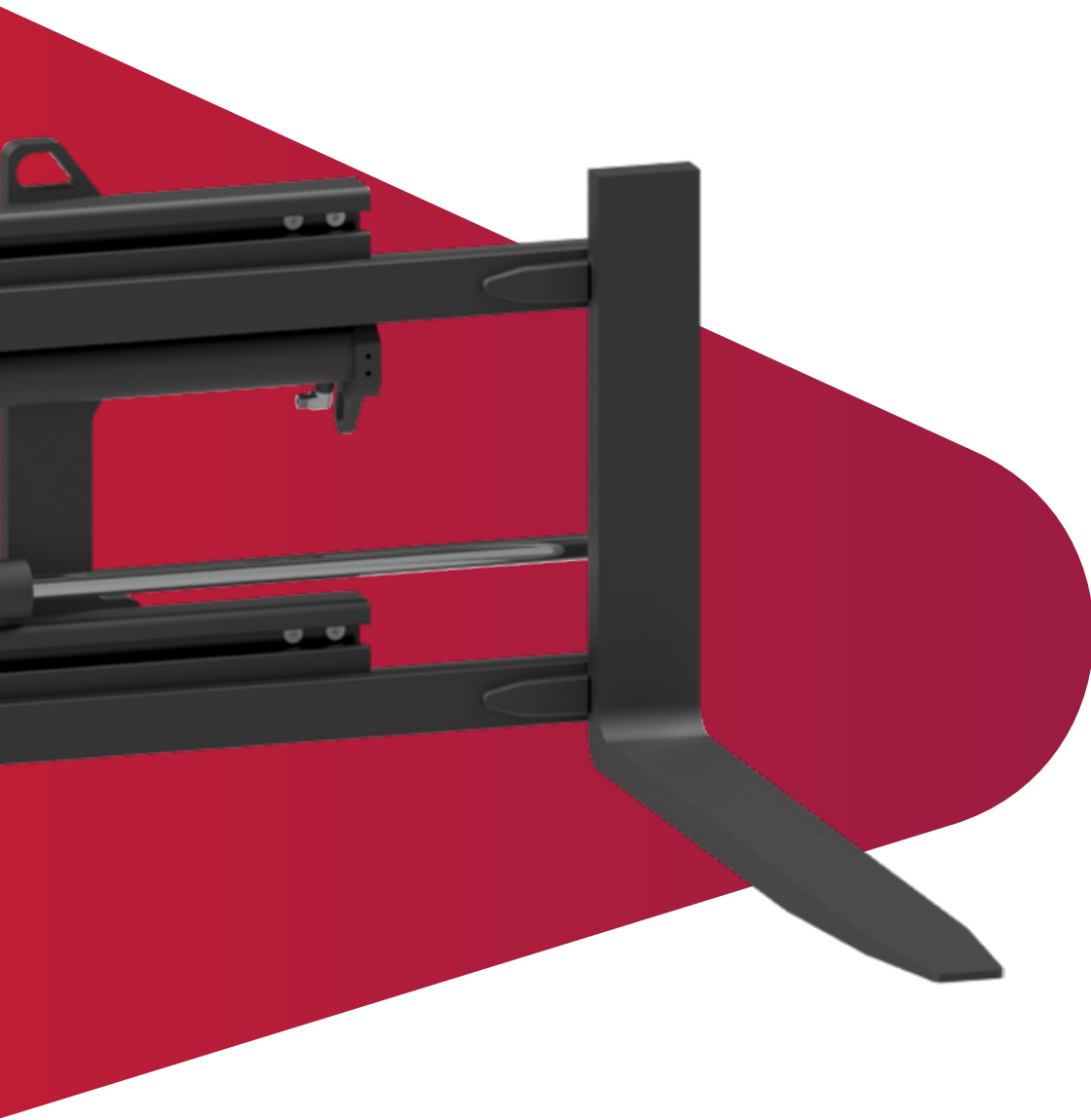

6. Clamps

The most reliable way to handle loads that aren't on pallets is with clamps! We have different types to suit every need, from fork clamps to tilting drum clamps and pallet inverter clamps.

HF-T

1000 kg
2600 kg

Fork clamp

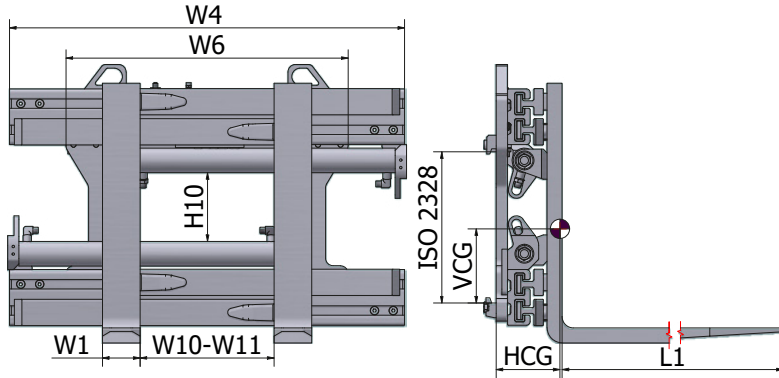

Product info

- Block valve with flow divider for excellent fork synchronization
- Pressure-regulating valve
- Excellent visibility through the frame
- W6 – Minimum carriage width
- Welded forks
- Models with valve block sideshift



Model	Capacity forks	Capacity clamp	W10–W11	W4	W6	Forks L1 x W1 x T1	H10	LL	HCG	VCG	Weight	ISO 2328	RRP
	kg/mm	kg/mm											mm
HF10-AQ0T-12*	1600/500	1000/500	230–1260	870	750	1200 x 100 x 35	195	170	199	167	280	2A	6150
HF10-A0T-12	1600/500	1000/500	450–1610	870	750	1200 x 100 x 35	195	170	198	168	290	2A	6150
HF10-B0T-12*	1600/500	1000/500	360–1500	950	750	1200 x 100 x 35	195	170	186	192	301	2A	6410
HF10-C0T-12*	1600/500	1000/500	360–1600	1050	750	1200 x 100 x 35	195	170	201	168	310	2A	6690
HF14-A0T-12	2000/500	1400/500	450–1610	870	750	1200 x 100 x 40	195	175	201	184	311	2A	6480
HF14-BQ0T-12*	2000/500	1400/500	340–1490	950	750	1200 x 100 x 40	195	175	199	167	315	2A	6800
HF14-B0T-12	2000/500	1400/500	450–1690	950	750	1200 x 100 x 40	195	175	196	186	317	2A	6800
HF14-C0T-12*	2000/500	1400/500	340–1580	1050	750	1200 x 100 x 40	195	175	196	188	330	2A	7110
HF14-DQ0T-12*	2000/500	1400/500	340–1680	1150	750	1200 x 100 x 40	195	175	202	184	328	2A	7450
HF14-D0T-12	2000/500	1400/500	550–1980	1150	750	1200 x 100 x 40	195	175	201	184	338	2A	7450
HF18-AQ0T-12*	2300/500	1900/500	340–1470	950	750	1200 x 100 x 40	185	175	193	188	317	2A	7230
HF18-A0T-12	2300/500	1900/500	480–1700	950	750	1200 x 100 x 40	185	175	192	189	327	2A	7230
HF18-B0T-12*	2300/500	1900/500	360–1580	1050	750	1200 x 100 x 40	185	175	189	193	336	2A	7590
HF18-B1T-12	2300/500	1900/500	480–1800	1050	750	1200 x 100 x 40	185	175	189	191	337	2A	7590
HF18-CQ0T-12*	2300/500	1900/500	250–1470	1150	750	1200 x 100 x 40	185	175	202	157	332	2A	7950
HF18-C0T-12	2300/500	1900/500	480–1900	1150	750	1200 x 100 x 40	185	175	201	158	342	2A	7950
HF18-D0T-12*	2300/500	1900/500	360–1580	1250	820	1200 x 100 x 40	185	175	199	158	349	2A	8310
HF18-EQ0T-12	2300/500	1900/500	650–2460	1320	820	1200 x 100 x 40	185	175	197	157	364	2A	8460
HF22-A0T-12	2500/500	2300/500	430–1660	950	750	1200 x 120 x 40	180	175	226	155	365	2A	7950
HF22-B1T-12*	2500/500	2300/500	300–1520	1050	750	1200 x 120 x 40	180	175	226	155	370	2A	8330
HF22-CQ0T-12*	2500/500	2300/500	240–1500	1150	750	1200 x 120 x 40	180	175	200	188	362	2A	8730
HF22-C0T-12	2500/500	2300/500	450–1900	1150	750	1200 x 120 x 40	180	175	199	186	382	2A	8730
HF22-D1T-12*	2500/500	2300/500	300–1720	1250	820	1200 x 120 x 40	180	175	226	155	389	2A	9110
HF26-AQ0T-12*	3200/500	2600/500	300–1520	1050	820	1200 x 120 x 45	180	180	220	177	363	3A	9280
HF26-A0T-12	3200/500	2600/500	450–1800	1050	820	1200 x 120 x 45	180	180	219	177	373	3A	9280
HF26-B1T-12*	3200/500	2600/500	300–1620	1150	820	1200 x 120 x 45	180	180	210	177	383	3A	9480
HF26-BQ0T-12	3200/500	2600/500	410–1830	1150	820	1200 x 120 x 45	180	180	209	177	393	3A	9480
HF26-C0T-12	3200/500	2600/500	420–1960	1250	820	1200 x 120 x 45	180	180	213	179	402	3A	10100
HF26-D1T-12*	3200/500	2600/500	320–1810	1320	820	1200 x 120 x 45	180	180	205	182	410	3A	10500

* Model for Euro-pallets

Fork clamp

HF-T

2800 kg
4500 kg

Product info

- Block valve with flow divider for excellent fork synchronization
- Pressure-regulating valve
- Excellent visibility through the frame
- W6 – Minimum carriage width
- Welded forks
- Models with valve block sideshift

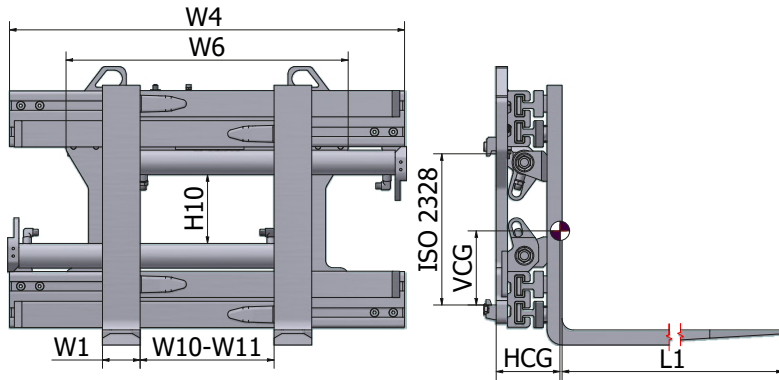

Model	Capacity forks	Capacity clamp	W10–W11	W4	W6	Forks L1 x W1 x T1	H10	LL	HCG	VCG	Weight	ISO 2328	RRP
	kg/mm	kg/mm											mm
HF30-A0T-12*	3600/500	2800/500	320–1620	1150	870	1200 x 120 x 50	175	217	206	180	567	3A	9740
HF30-B0T-12	3600/500	2800/500	450–1970	1250	870	1200 x 120 x 50	175	217	210	192	580	3A	9940
HF30-C0T-12*	3600/500	2800/500	320–1780	1320	870	1200 x 120 x 50	175	217	208	192	592	3A	10160
HF35-A0T-12*	4500/500	3500/500	260–1560	1150	870	1200 x 150 x 50	170	217	223	189	609	3A	11340
HF35-B0T-12*	4500/500	3500/500	260–1720	1320	870	1200 x 150 x 50	170	217	218	189	652	3A	11930
HF35-C0T-12	4500/500	3500/500	390–2120	1450	1000	1200 x 150 x 50	170	217	214	189	670	3A	12160
HF42-AQ0T-12*	4500/600	3500/600	260–1600	1250	950	1200 x 150 x 60	160	235	225	249	747	4A	12410
HF42-AQ1T-12	4500/600	3500/600	420–1920	1250	950	1200 x 150 x 60	160	235	221	248	753	4A	12410
HF42-BQ0T-12	4500/600	3500/600	410–2110	1450	950	1200 x 150 x 60	160	235	217	248	783	4A	12840
HF42-CQ0T-12*	4500/600	3500/600	250–1930	1600	950	1200 x 150 x 60	160	235	213	247	800	4A	13170
HF42-DQ03T-12*	5200/500	4200/500	260–1510	1150	920	1200 x 150 x 60	170	235	228	248	720	3A	12180
HF42-AQ03T-12*	5200/500	4200/500	260–1620	1250	920	1200 x 150 x 60	170	235	225	248	743	3A	12410
HF42-EQ03T-12*	5200/500	4200/500	250–1700	1320	920	1200 x 150 x 60	170	235	222	248	762	3A	12410
HF42-BQ03T-12	5200/500	4200/500	450–2180	1450	920	1200 x 150 x 60	170	235	217	248	773	3A	12840
HF45-A0T-12	5500/600	4500/600	350–1970	1450	1050	1200 x 150 x 60	190	235	208	267	795	4A	12950
HF45-B0T-12	5500/600	4500/600	300–2000	1600	1050	1200 x 150 x 60	190	235	205	267	855	4A	13220

* Model for Euro-pallets

Options

	RRP
	Euro
Separate sideshifter: 100 + 100 mm for ISO/FEM 2	825
Separate sideshifter: 100 + 100 mm for ISO/FEM 3	1345
Separate sideshifter: 100 + 100 mm for ISO/FEM 4	1995
2 hydraulic functions – Independent arm control	640
Quick-release lower mountings, class 2 or class 3	605
Quick-release lower mountings, class 4	810
Double maximum pressure control valve	685
Frame bumper	260

Available on request

- Different fork dimensions
- Bolted forks
- Class B forks
- Other opening ranges
- Models without sideshifter
- Wear strip under the forks
- Dedicated load backrests

HFR**1600 kg
2500 kg**

Rotating fork clamp 360°

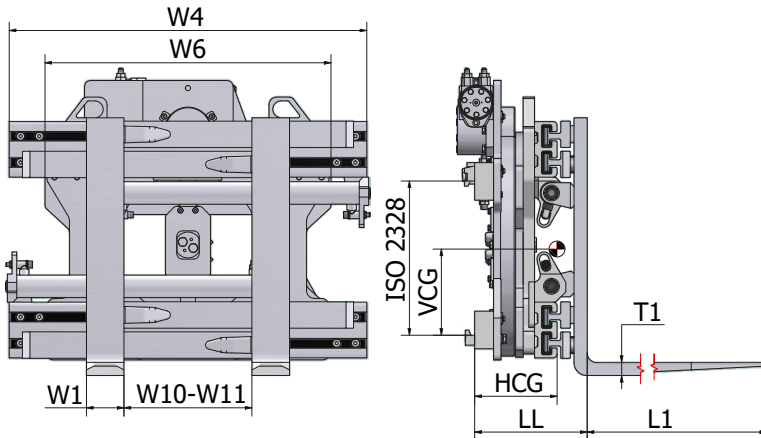

Product info

- 360° rotation
- Continuous rotation in both directions
- Fast rotation and high torque
- Block valve with flow divider for excellent fork synchronization
- Pressure-regulating valve
- Excellent visibility through the frame
- W6 – Minimum carriage width
- Welded forks
- Without sideshifter



Model	Capacity forks	Capacity clamp	W10–W11	W4	W6	Forks L1 x W1 x T1	H10	LL	HCG	VCG	Weight	ISO 2328	RRP
	kg/mm	kg/mm											mm
HFR10-B0-12*	1600/500	1000/500	340–1480	950	750	1200 x 100 x 35	195	299	219	229	492	2A	13580
HFR10-C0-12*	1600/500	1000/500	350–1590	1050	750	1200 x 100 x 35	195	299	218	230	508	2A	13840
HFR14-BQ1-12*	2000/500	1400/500	310/1420	950	750	1200 x 100 x 40	195	304	231	225	506	2A	13970
HFR14-B0-12	2000/500	1400/500	450–1690	950	750	1200 x 100 x 40	195	304	229	227	510	2A	13970
HFR14-C0-12*	2000/500	1400/500	350–1590	1050	750	1200 x 100 x 40	195	304	229	226	522	2A	14280
HFR14-D0-12	2000/500	1400/500	550–1980	1150	750	1200 x 100 x 40	195	304	229	225	538	2A	14590
HFR18-AQ1-12*	2300/500	1800/500	330–1450	950	750	1200 x 100 x 40	185	309	229	235	520	2A	14650
HFR18-A0-12	2300/500	1800/500	480–1700	950	750	1200 x 100 x 40	185	304	228	227	506	2A	14650
HFR18-B0-12*	2300/500	1800/500	360–1580	1050	750	1200 x 100 x 40	185	304	228	226	526	2A	15000
HFR18-B1-12	2300/500	1800/500	480–1800	1050	750	1200 x 100 x 40	185	304	228	225	540	2A	15000
HFR18-CQ0-12*	2300/500	1800/500	250–1470	1150	750	1200 x 100 x 40	185	309	229	235	560	2A	15330
HFR18-C0-12	2300/500	1800/500	480–1920	1150	750	1200 x 100 x 40	185	309	229	235	570	2A	15330
HFR18-D0-12*	2300/500	1800/500	360–1780	1250	750	1200 x 100 x 40	185	309	229	235	585	2A	15650
HFR22-A0-12	2500/500	2200/500	430–1660	950	750	1200 x 120 x 40	180	309	248	226	550	2A	15490
HFR22-B1-12*	2500/500	2200/500	300–1520	1050	750	1200 x 120 x 40	180	309	247	225	559	2A	15590
HFR22-C0-12	2500/500	2200/500	450–1900	1150	750	1200 x 120 x 40	180	309	246	224	580	2A	15920
HFR22-D1-12*	2500/500	2200/500	320–1740	1250	750	1200 x 120 x 40	180	309	243	223	600	2A	16290

* Model for Euro-pallets

Options

	RRP
	Euro
Separate sideshifter: 100 + 100 mm for ISO/FEM 2	1330
Quick-release lower mountings, class 2	605
Double maximum pressure control valves	685
Frame bumper	260

Rotating fork clamp 360°

HFR

3200 kg
5000 kg

Product info

- 360° rotation
- Continuous rotation in both directions
- Fast rotation and high torque
- Block valve with flow divider for excellent fork synchronization
- Pressure-regulating valve
- Excellent visibility through the frame
- W6 – Minimum carriage width
- Welded forks
- without sidershifter

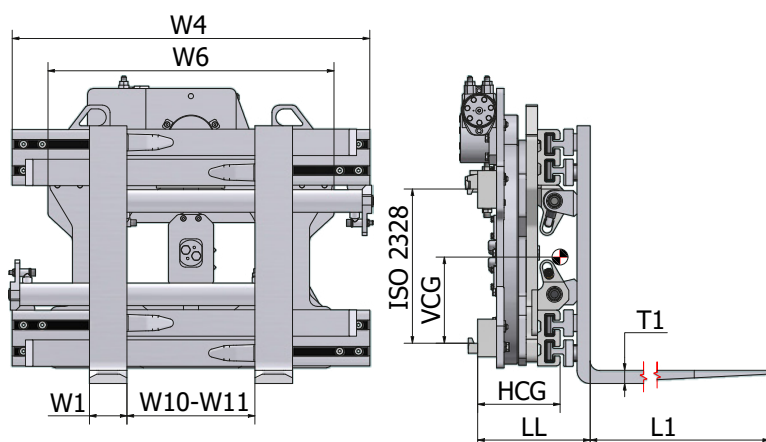

Model	Capacity forks	Capacity clamp	W10–W11	W4	W6	Forks L1 x W1 x T1	H10	LL	HCG	VCG	Weight	ISO 2328	RRP
	kg/mm	kg/mm											mm
HFR26-AQ1-12*	3200/500	2600/500	260–1450	1050	900	1200 x 120 x 45	180	317	243	256	618	3A	16080
HFR26-A0-12	3200/500	2600/500	440–1790	1050	900	1200 x 120 x 45	180	308	240	252	604	3A	16080
HFR26-B1-12*	3200/500	2600/500	300–1620	1150	900	1200 x 120 x 45	180	308	239	253	620	3A	16470
HFR26-CQ1-12*	3200/500	2600/500	250–1620	1250	900	1200 x 120 x 45	180	308	239	256	645	3A	16820
HFR26-C0-12	3200/500	2600/500	440–1980	1250	900	1200 x 120 x 45	180	317	241	256	655	3A	16820
HFR26-D1-12*	3200/500	2600/500	320–1810	1320	900	1200 x 120 x 45	180	317	239	256	674	3A	17030
HFR30-A0-12*	3600/500	2800/500	320–1610	1150	900	1200 x 120 x 50	175	352	257	293	799	3A	17960
HFR30-B0-12	3600/500	2800/500	450–1970	1250	900	1200 x 120 x 50	175	352	256	295	825	3A	18230
HFR30-C0-12*	3600/500	2800/500	320–1780	1320	900	1200 x 120 x 50	175	352	255	297	840	3A	18480
HFR35-A0-12*	4200/500	3500/500	260–1560	1150	1050	1200 x 150 x 50	170	352	275	283	845	3A	21000
HFR35-B0-12*	4200/500	3500/500	250–1730	1320	1050	1200 x 150 x 50	170	352	272	286	889	3A	21600
HFR35-C0-12	4200/500	3500/500	390–2120	1450	1050	1200 x 150 x 50	170	352	269	289	950	3A	21890
HFR40-A0-12*	4800/500	4000/500	260–1560	1150	1050	1200 x 150 x 60	165	380	256	279	1015	3A	22420
HFR40-B0-12	4800/500	4000/500	450–2050	1320	1050	1200 x 150 x 60	165	380	259	279	1050	3A	22630
HFR40-C0-12	4800/500	4000/500	450–2180	1450	1050	1200 x 150 x 60	165	380	263	279	1090	3A	22910
HFR45-A0-12	5000/600	3800/600	350–1970	1450	1230	1200 x 150 x 60	210	400	277	377	1252	4A	25700
HFR45-B0-12	5000/600	3800/600	450–2320	1600	1230	1200 x 150 x 60	210	400	277	380	1306	4A	25950
HFR45-C0-12*	5000/600	3800/600	260–1660	1320	1230	1200 x 150 x 60	210	400	277	375	1205	4A	25390

* Model for Euro-pallets

Options

	RRP
	Euro
Separate sidershifter: 100 + 100 mm for ISO/FEM 3	1800
Separate sidershifter: 100 + 100 mm for ISO/FEM 4	2140
Quick-release lower mountings, class 3	605
Quick-release lower mountings, class 4	810
Double maximum pressure control valves	685
Frame bumper	260

HP-T

1400 kg
3500 kg

Rotating 90° pivoting fork clamp manually operated

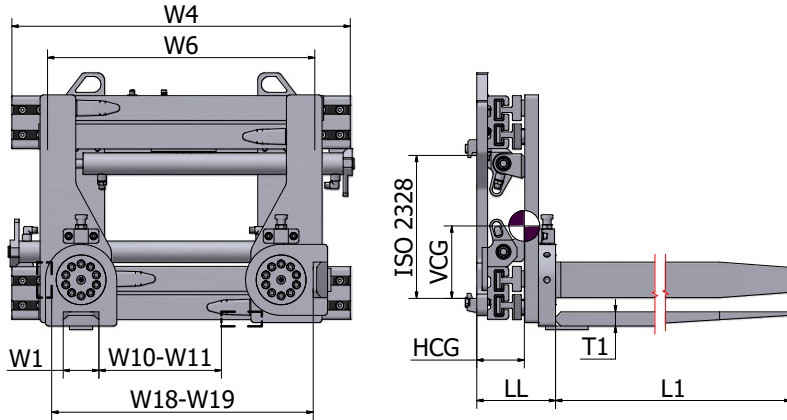

Product info

- Block valve with flow divider for excellent fork synchronization
- Pressure-regulating valve
- Excellent visibility through the frame
- Manual fork positioning at 0°- 45° - 90°
- W6 – Minimum carriage width
- With valve block sideshifter
- Welded forks
- Ideal for handling pallets, drums, rolls, tires, bales and similar loads



Model	Capacity forks	Capacity clamp	W10–W11	W18–W19	W4	W6	Forks L1 x W1 x T1	H10	LL	HCG	VCG	Weight	ISO 2328	RRP
	kg/mm	kg/mm	mm	mm	mm	mm	mm	mm	mm	mm	mm	kg		Euro
HP10-A0T-10*	1400/500	1000/500	360–1600	640–1880	950	750	1000 x 100 x 40	195	221	179	188	359	2A	7870
HP10-A0T-12*	1400/500	1000/500	360–1600	640–1880	950	750	1200 x 100 x 40	195	221	202	183	370	2A	8010
HP14-A0T-10*	1800/500	1400/500	300–1640	610–1950	1050	750	1000 x 130 x 40	195	221	190	180	375	2A	8300
HP14-A0T-12*	1800/500	1400/500	300–1640	610–1950	1050	750	1200 x 130 x 40	195	221	225	177	403	2A	8430
HP18-A0T-12*	2300/500	1800/500	220–1440	520–1740	1050	750	1200 x 120 x 50	185	221	240	171	413	2A	9000
HP18-B0T-12*	2300/500	1800/500	300–1720	600–2020	1150	750	1200 x 120 x 50	185	221	233	175	432	2A	9180
HP22-A0T-12*	2600/500	2200/500	220–1440	520–1740	1050	750	1200 x 120 x 50	180	221	238	171	416	2A	9780
HP22-B0T-12*	2600/500	2200/500	300–1720	600–2020	1150	750	1200 x 120 x 50	180	221	234	180	441	2A	9920
HP26-A0T-12*	3200/500	2600/500	260–1570	630–1940	1050	750	1200 x 150 x 50	175	231	255	166	498	3A	11410
HP26-B0T-12*	3200/500	2600/500	260–1670	630–2040	1150	750	1200 x 150 x 50	175	231	251	167	511	3A	11530
HP30-A0T-12*	3500/500	3000/500	160–1460	530–1830	1150	800	1200 x 150 x 50	175	261	239	219	672	3A	13590
HP30-B0T-12	3500/500	3000/500	410–1880	780–2250	1250	850	1200 x 150 x 50	175	261	235	162	702	3A	13710

* Model for Euro-pallets

Options

	RRP
	Euro
Separate sideshifter: 100 + 100 mm for ISO/FEM 2	1330
Separate sideshifting 100 + 100 mm for ISO/FEM 3	1800
2 hydraulic functions – Independent arm control	640
Quick-release lower mountings, class 2 or class 3	605
Double maximum pressure control valve	685
Frame bumper	260

Available on request

- Models without sideshifter
- Different fork dimensions
- Other opening ranges
- Black rubber-padded forks
- Hydraulically pivoting forks

Rotating 90° pivoting fork clamp manually operated 360°

HPR

1400 kg
3200 kg

Product info

- 360° rotation
- Continuous rotation in both directions
- Fast rotation and high torque
- Block valve with flow divider for excellent fork synchronization
- Pressure-regulating valve
- Excellent visibility through the frame
- Manual fork positioning at 0°- 45° - 90°
- W6 – Minimum carriage width
- Welded forks
- Without sideshifter
- Ideal for handling pallets, drums, rolls, tires, bales and similar loads

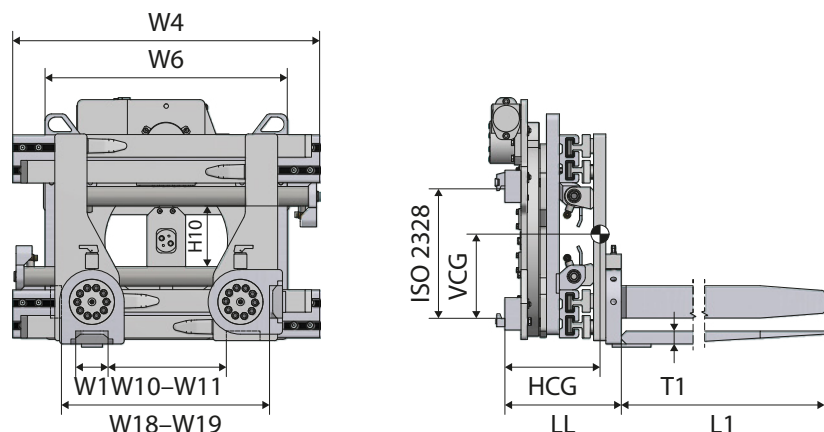

Model	Capacity forks	Capacity clamp	W10–W11	W18–W19	W4	W6	Forks L1 x W1 x T1	H10	LL	HCG	VCG	Weight	ISO 2328	RRP
	kg/mm	kg/mm												mm
HPR10-A0-10*	1400/500	1000/500	360–1600	640–1880	950	750	1000 x 100 x 40	195	355	226	227	564	2A	15230
HPR10-A0-12*	1400/500	1000/500	360–1600	640–1880	950	750	1200 x 100 x 40	195	350	240	220	560	2A	15370
HPR14-A0-10*	1800/500	1400/500	300–1640	610–1950	1050	750	1000 x 130 x 40	195	355	259	208	608	2A	15650
HPR14-A0-12*	1800/500	1400/500	300–1640	610–1950	1050	750	1200 x 130 x 40	195	350	262	213	591	2A	15790
HPR18-A0-12*	2300/500	1800/500	220–1440	520–1740	1050	750	1200 x 120 x 50	185	358	272	212	616	2A	16630
HPR18-B0-12*	2300/500	1800/500	320–1740	620–2040	1150	750	1200 x 120 x 50	185	358	286	213	637	2A	16800
HPR22-A0-12*	2600/500	2200/500	220–1440	520–1740	1050	750	1200 x 120 x 50	180	360	273	206	625	2A	17520
HPR22-B0-12*	2600/500	2200/500	320–1740	620–2040	1150	750	1200 x 120 x 50	180	360	288	213	641	2A	17640
HPR26-A0-12*	3200/500	2600/500	260–1570	630–1940	1050	900	1200 x 150 x 50	175	359	280	239	735	3A	19970
HPR26-B0-12*	3200/500	2600/500	260–1670	630–2040	1150	900	1200 x 150 x 50	175	359	281	236	740	3A	20090

* Model for Euro-pallets

Options

	RRP
	Euro
Separate sideshifter: 100 + 100 mm for ISO/FEM 2	1330
Separate sideshifter: 100 + 100 mm for ISO/FEM 3	1800
Quick-release lower mountings, class 2 or class 3	605
Double max. pressure control valve	685

Available on request

- Different fork dimensions
- Other opening ranges
- Black rubber-padded forks

H**1000 kg
2200 kg**

Load clamp without arms

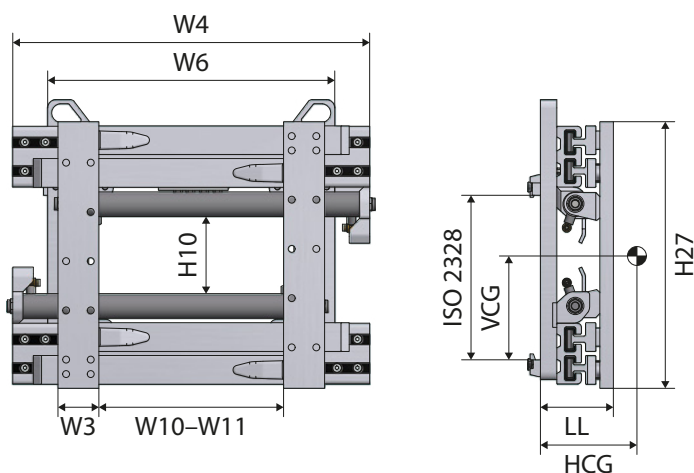

Product info

- W6 – Minimum carriage width
- Without sideshifter
- Technical data without forks/arms
- Block valve with flow divider
- Excellent visibility through the frame



Model	Capacity	W10–W11	W4	W6	H27	W3	H10	LL	HCG	VCG	Weight	ISO 2328	RRP
	kg/mm	mm	mm	mm	mm	mm	mm	mm	mm	mm	kg		Euro
H10-A0	1000/500	450–1610	870	750	635	100	195	163	74	208	234	2	5280
H10-B0*	1000/500	360–1500	950	750	635	100	195	163	72	208	242	2	5330
H10-C0*	1000/500	360–1580	1050	750	635	100	195	163	71	208	252	2	5430
H14-A0	1400/500	450–1610	870	750	635	100	195	163	75	208	236	2	5510
H14-B0	1400/500	450–1690	950	750	635	100	195	163	74	208	244	2	5570
H14-C0*	1400/500	360–1600	1050	750	635	100	195	163	73	208	254	2	5700
H14-D0	1400/500	550–1980	1150	750	635	100	195	163	74	208	262	2	5860
H18-A0	1800/500	480–1700	950	750	635	100	185	168	73	210	260	2	5800
H18-B0	1800/500	480–1800	1050	750	635	100	185	168	73	210	268	2	5940
H18-B1*	1800/500	360–1580	1050	750	635	100	185	168	73	210	268	2	5940
H18-C0	1800/500	480–1900	1150	750	635	100	185	168	73	210	282	2	6220
H18-D0*	1800/500	360–1780	1250	850	635	100	185	168	73	210	292	2	6420
H22-A0	2200/500	450–1700	950	750	635	120	180	168	76	213	265	2	6170
H22-B0*	2200/500	320–1540	1050	750	635	120	180	168	74	213	273	2	6290
H22-C0	2200/500	450–1900	1150	750	635	120	180	168	74	213	288	2	6580
H22-D0*	2200/500	320–1740	1250	750	635	120	180	168	74	213	296	2	6800

* Model for Euro-pallets

Options

	RRP
	Euro
2 hydraulic functions – Integrated sideshifter	630
Separate sideshifter: 100 + 100 mm for ISO/FEM 2	1330
2 hydraulic functions – Independent arm control	640
Quick-release lower mountings, class 2	605

Load clamp without arms

H

2600 kg
5000 kg

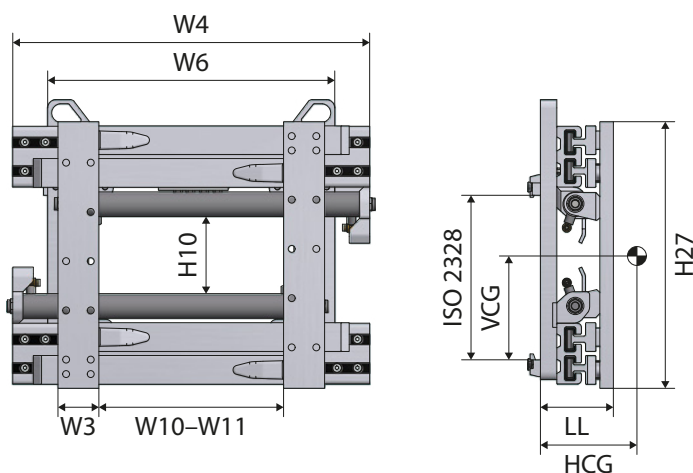

Product info

- W6 – Minimum carriage width
- Without sideshifter
- Technical data without forks/arms
- Block valve with flow divider
- Excellent visibility through the frame



Model	Capacity	W10–W11	W4	W6	H27	W3	H10	LL	HCG	VCG	Weight	ISO 2328	RRP
	kg/mm	mm	mm	mm	mm	mm	mm	mm	mm	mm	kg		Euro
H26-A0	2600/500	450–1800	1050	850	635	120	180	170	74	259	275	3	6670
H26-B0*	2600/500	320–1640	1150	850	635	120	180	170	74	259	290	3	6990
H26-C0	2600/500	450–1990	1250	850	635	120	180	170	74	259	305	3	7200
H26-D0*	2600/500	320–1810	1320	850	635	120	180	170	68	218	315	3	7420
H30-A0*	3000/500	320–1620	1150	870	765	120	160	204	90	324	480	3	8280
H30-B0	3000/500	450–1970	1250	870	765	120	160	204	88	322	510	3	8660
H30-C0*	3000/500	320–1780	1320	870	765	120	160	204	78	320	529	3	8920
H35-A0*	3500/500	320–1620	1150	870	765	120	160	204	91	322	490	3	10500
H35-B0*	3500/500	320–1790	1320	870	765	120	160	204	89	320	520	3	10730
H35-C0	3500/500	450–2180	1450	1000	765	120	160	204	95	318	533	3	10920
H40-A0*	4000/500	320–1620	1150	900	843	150	165	209	95	241	500	3	10980
H40-B0	4000/500	450–2050	1320	1000	843	150	165	209	93	241	530	3	11200
H40-C0	4000/500	450–2180	1450	1000	843	150	165	209	92	241	555	3	11500
H45-A0	3800/600	350–1970	1450	1050	843	150	210	220	98	274	621	4	11660
H45-B0	3800/600	450–2320	1600	1050	843	150	210	220	96	274	661	4	11960
H60-A0	5000/600	380–2200	1600	1050	920	180	150	265	110	274	960	4	On request
H60-B0	5000/600	380–2400	1800	1050	920	180	150	265	110	274	1020	4	On request

* Model for Euro-pallets

Options

	RRP
	Euro
2 hydraulic functions – Integrated sideshifter	630
Separate sideshifter: 100 + 100 mm for ISO/FEM 3	1800
Separate sideshifter: 100 + 100 mm for ISO/FEM 4	2140
2 hydraulic functions – Independent arm control	640
Quick-release lower mountings, class 3	605
Quick-release lower mountings, class 4	810

HR

1000 kg
2600 kg

Rotating load clamp 360° without arms

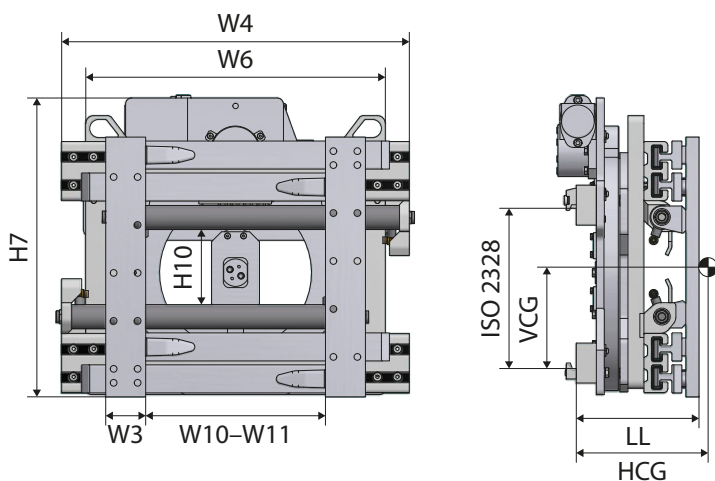

Product info

- 360° rotation
- Continuous rotation in both directions
- Fast rotation and high torque
- Block valve with flow divider
- Excellent visibility through the frame
- W6 – Minimum carriage width
- Without sideshifter
- Technical data without forks/arms



Model	Capacity	W10–W11 mm	W4 mm	W6 mm	W3 mm	H10 mm	H7 mm	LL mm	HCG mm	VCG mm	Weight kg	ISO 2328	RRP
	kg/mm												Euro
HR10-A0	1000/500	450–1610	870	750	100	195	635	307	146	273	436	2	12630
HR10-B0*	1000/500	360–1500	950	750	100	195	635	307	145	274	460	2	12700
HR10-C0*	1000/500	360–1580	1050	750	100	195	635	307	144	275	470	2	12790
HR14-A0	1400/500	450–1610	870	750	100	195	635	307	146	273	465	2	12870
HR14-B0	1400/500	450–1690	950	750	100	195	635	307	145	274	470	2	15180
HR14-C0*	1400/500	360–1600	1050	750	100	195	635	307	144	275	475	2	15400
HR14-D0	1400/500	550–1980	1150	750	100	195	635	307	143	276	480	2	15640
HR18-A0	1800/500	480–1700	950	750	100	185	635	307	146	273	470	2	13430
HR18-B0	1800/500	480–1800	1050	750	100	185	635	307	145	274	475	2	13570
HR18-B1*	1800/500	360–1580	1050	750	100	185	635	307	145	274	473	2	13570
HR18-C0	1800/500	480–1900	1150	750	100	185	635	307	144	275	485	2	13860
HR18-D0*	1800/500	360–1780	1250	850	100	185	635	307	143	276	494	2	14060
HR22-A0	2300/500	430–1660	950	750	120	180	635	307	146	273	474	2	13890
HR22-B0*	2200/500	320–1540	1050	750	120	180	635	307	145	274	480	2	14030
HR22-C0	2200/500	450–1900	1150	750	120	180	635	307	144	275	487	2	14320
HR22-D0*	2200/500	320–1740	1250	750	120	180	635	307	143	276	493	2	14530
HR26-A0	2600/500	450–1800	1050	900	120	180	635	307	143	297	610	3	15220
HR26-B0*	2600/500	320–1640	1150	900	120	180	635	307	145	297	617	3	15520

* Model for Euro-pallets

Options

	RRP
	Euro
Separate sideshifter: 100 + 100 mm for ISO/FEM 2	1330
Separate sideshifter: 100 + 100 mm for ISO/FEM 3	1800
Separate sideshifter: 100 + 100 mm for ISO/FEM 4	2140
Quick-release lower mountings, class 2 or class 3	605
Quick-release lower mountings, class 4	810

Rotating load clamp 360° without arms

HR

2600 kg
3800 kg

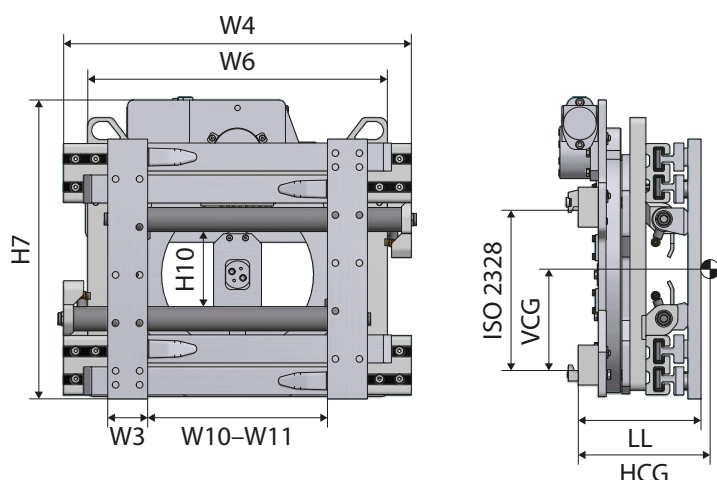

Product info

- 360° rotation
- Continuous rotation in both directions
- Fast rotation and high torque
- Block valve with flow divider
- Excellent visibility through the frame
- W6 – Minimum carriage width
- Without sideshifter
- Technical data without forks/arms



Model	Capacity	W10–W11 mm	W4 mm	W6 mm	W3 mm	H10 mm	H7 mm	LL mm	HCG mm	VCG mm	Weight kg	ISO 2328	RRP
	kg/mm												Euro
HR26-C0	2600/500	450–2000	1250	900	120	180	635	307	147	297	626	3	15730
HR26-D0*	2600/500	320–1810	1320	900	120	180	635	307	150	297	638	3	15960
HR30-A0*	3000/500	320–1620	1150	900	120	175	745	337	147	325	725	3	16820
HR30-B0	3000/500	450–1970	1250	900	120	175	745	337	151	325	740	3	17200
HR30-C0*	3000/500	320–1780	1320	900	120	175	745	337	152	325	752	3	17680
HR35-A0*	3500/500	320–1620	1150	1050	120	170	745	350	162	328	795	3	19050
HR35-B0*	3500/500	320–1790	1320	1050	120	170	745	350	165	328	810	3	19270
HR35-C0	3500/500	450–2180	1450	1050	120	170	745	350	169	328	827	3	19470
HR40-A0*	4000/500	320–1620	1150	1050	150	165	745	355	165	328	812	3	20200
HR40-B0	4000/500	450–2050	1320	1050	150	165	745	355	171	328	821	3	20410
HR40-C0	4000/500	450–2180	1450	1050	150	165	745	355	177	328	831	3	20970
HR45-A0	3800/600	350–1970	1450	1230	150	210	820	380	189	338	1080	4	24950
HR45-B0	3800/600	450–2320	1600	1230	150	210	820	380	197	338	1125	4	25770

* Model for Euro-pallets

Options

	RRP
	Euro
Separate sideshifter: 100 + 100 mm for ISO/FEM 2	1330
Separate sideshifter: 100 + 100 mm for ISO/FEM 3	1800
Separate sideshifter: 100 + 100 mm for ISO/FEM 4	2140
Quick-release lower mountings, class 2 or class 3	605
Quick-release lower mountings, class 4	810

HX-T**1800 kg
2200 kg**

Basket clamp with rubber-faced arms

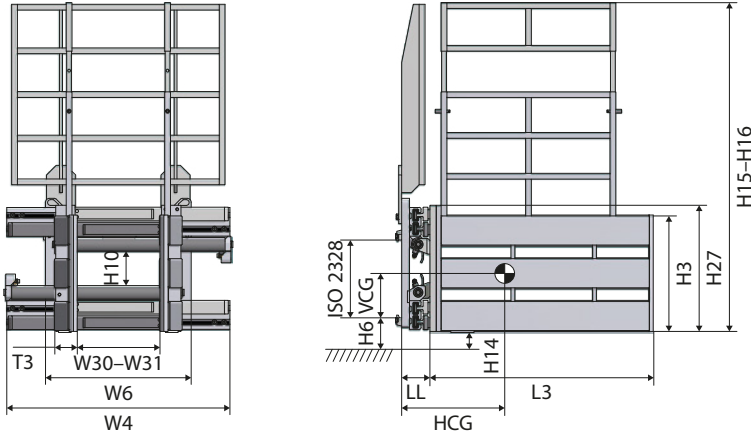

Product info

- Block valve with flow divider for excellent arms synchronization
- Pressure-regulating valve
- Rubber pads bolted onto the arms to prevent damage to the load
- W6 – Minimum carriage width
- Load backrest with movable top part
- Models with valve block sideshifter
- Bolted arms



Model	Capacity	W30-W31	W4	W6	H27	H15-H16	H14	H6	Arms L3 x H3 x T3	H10	LL	HCG	VCG	Weight	ISO 2328	RRP
																Euro
HX18T	1800/500	440-1760	1050	750	640	1500-1700	15	76	1040 x 600 x 120	185	125	298	362	525	2A	11620
HX22T	2200/500	420-1840	1150	750	640	1500-1700	15	76	1060 x 600 x 120	180	125	295	367	541	2A	12980

This basket clamp efficiently handles boxed items, saving the user money on pallet purchasing and maintenance.

Options

	RRP
	Euro
Separate sideshifter: 100 + 100 mm for ISO/FEM 2	1330
2 hydraulic functions – Independent arm control	640
Quick-release lower mountings, class 2	605
Double max. pressure control valve	685
Frame bumper	260

Available on request

- Other opening ranges
- Models without sideshifter
- Manometer

Basket clamp with articulating rubber-faced arms

HOX
1600 kg

Product info

- Block valve with flow divider for excellent arms synchronization
- Pressure-regulating valve
- Rubber pads bolted onto the arms to prevent damage to the load
- Arm articulation system to adapt to loads without damaging them
- W6 – Minimum carriage width
- Welded arms
- Without sideshifter

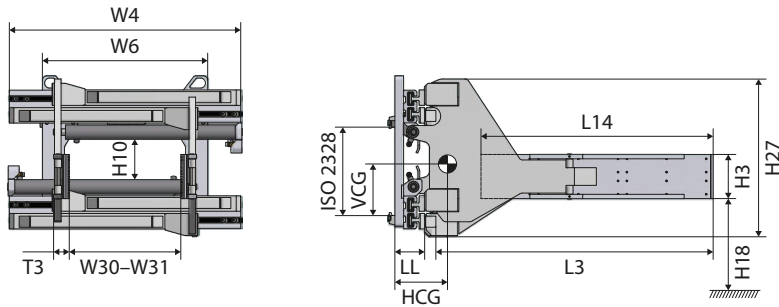

Model	Capacity	W30-W31	W4	W6	H27	H18	L14	Arms L3 x H3 x T3	H10	LL	HCG	VCG	Weight	ISO 2328	RRP
	kg/mm														mm
HOX18-A0-105	1600/500	490-1810	1050	750	700	170	1000	1050 x 200 x 70	185	175	265	495	432	2A	10890
HOX18-A0-115	1600/500	490-1810	1050	750	700	170	1100	1150 x 200 x 70	185	175	272	495	440	2A	11280
HOX18-A0-125	1600/500	490-1810	1050	750	700	170	1200	1250 x 200 x 70	185	175	278	495	457	2A	11590
HOX18-A0-105B	1600/500	490-1810	1050	750	700	0	1000	1050 x 200 x 70	185	175	267	495	437	2A	10890
HOX18-A0-115B	1600/500	490-1810	1050	750	700	0	1100	1150 x 200 x 70	185	175	275	495	445	2A	11280
HOX18-A0-125B	1600/500	490-1810	1050	750	700	0	1200	1250 x 200 x 70	185	175	281	495	462	2A	11590

This basket clamp efficiently handles boxed items, saving the user money on pallet purchasing and maintenance.

Options

	RRP
	Euro
Separate sideshifting 100 + 100 mm for ISO/FEM 2	1330
2 hydraulic functions – Independent arm control	640
2 hydraulic functions - Integrated sideshifting	630
Quick-release lower mountings, class 2	605
Double max. pressure control valve	685
Frame bumper	260

Available on request

- Bolted arms
- Other opening ranges
- Manometer

HD**1000 kg
1800 kg**

Drum clamp

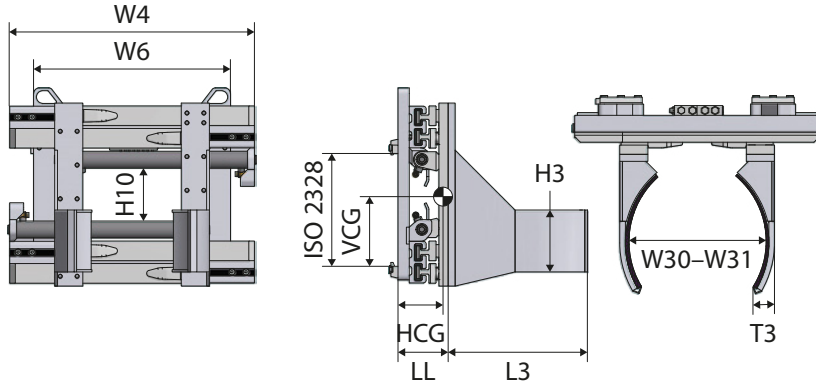

Product info

- Block valve with flow divider for excellent arms synchronization
- Pressure-regulating valve
- Excellent visibility through the frame
- Arms with rubberized plates to avoid damage to the load
- Arms with easily replaceable rubber p
- W6 – Minimum carriage width
- Bolted arms
- Without sidsifter



Model	Capacity	W30–W31	W4	W6	Arms L3 x H3 x T3	Drum Ø	H10	LL	HCG	VCG	Weight	ISO 2328	RRP
	kg/mm												mm
1/2 drum clamps													
HD10-A0	1000/500	470–1530	870	750	500 x 220 x 80	600	195	125	139	234	295	2A	6560
HD14-A0	1400/500	470–1530	870	750	500 x 220 x 80	600	195	125	142	232	300	2A	6800
HD18-A0	1800/500	470–1660	1050	750	500 x 220 x 80	600	185	125	135	230	330	2A	8230
2/4 drum clamps													
HDD14-A0	1400/500	370–1430	870	750	1090 x 220 x 80	600	195	125	304	199	330	2A	7920
HDD18-A0	1800/500	370–1560	1050	750	1090 x 220 x 80	600	185	125	291	204	350	2A	8540

Options

	RRP
	Euro
Separate sidsifter: 100 + 100 mm for ISO/FEM 2	1330
Quick-release lower mountings, class 2	640
2 hydraulic functions – Independent arm control	605
2 hydraulic functions – Integrated sidsifting	630
Double max. pressure control valve	685
Frame bumper	260

Available on request

- Different arm dimensions
- Other opening ranges
- Manometer

Advantages

- Expertly manufactured
- Superior mechanical strength

Rotating drum clamp 360°

HDR

1000 kg
1800 kg

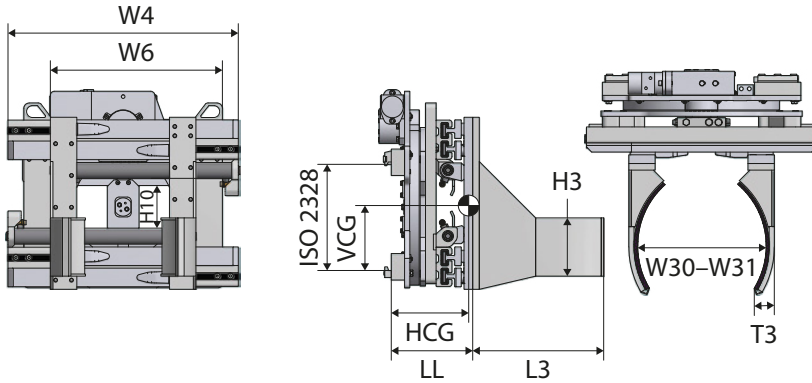

Product info

- 360° rotation
- Continuous rotation in both directions
- Fast rotation and high torque
- Block valve with flow divider for excellent arms synchronization
- Pressure-regulating valve
- Excellent visibility through the frame
- Arms with rubberized plates to avoid damage to the load
- Arms with easily replaceable rubber plates
- W6 – Minimum carriage width
- Bolted arms
- Without sideshifter



Model	Capacity	W30–W31	W4	W6	Arms L3 x H3 x T3	Drum Ø	H10	LL	HCG	VCG	Weight	ISO 2328	RRP
	kg/mm												mm
1/2 drum 360° rotating clamps													
HDR10-A0	1000/500	470–1530	870	750	500 x 220 x 80	600	180	254	185	253	500	2A	14800
HDR14-A0	1400/500	470–1530	870	750	500 x 220 x 80	600	180	254	188	257	517	2A	15040
HDR18-A0	1800/500	470–1660	1050	750	500 x 220 x 80	600	170	256	170	248	580	2A	17170
2/4 drum 360° rotating clamps													
HDDR14-A0	1400/500	370–1430	870	750	1090 x 220 x 80	600	180	264	282	268	600	2A	16490
HDDR18-A0	1800/500	370–1560	1050	750	1090 x 220 x 80	600	170	264	278	267	625	2A	17930

Options

	RRP
	Euro
Separate sideshifter: 100 + 100 mm for ISO/FEM 2	1330
2 hydraulic functions – Independent arm control	965
Quick-release lower mountings, class 2	605

Available on request

- Bolted arms
- Other opening ranges
- Manometer

HZ**800 kg
1800 kg**

Tilting drum clamp 180°

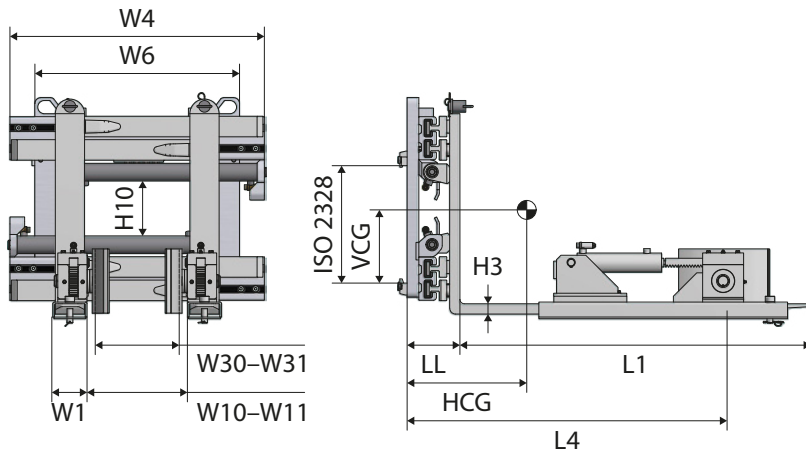

Product info

- Block valve with flow divider for excellent fork synchronization
- Excellent visibility through the frame
- Robust 180° drum tilting system
- Tipping system on slip on: greater versatility of the clamp
- W6 – Minimum carriage width
- Welded arms
- Without sideshifter



Model	Capacity on fork	Front tipping capacity	W10-W11	W30-W31	W4	W6	L4	Forks L1 x W1 x T1	Drum Ø	H10	LL	HCG	VCG	Weight	ISO 2328	RRP
	kg/mm															kg
HZ08-A0	800/500	400	360-1420	240-1300	870	750	1080	1200 x 100 x 35	600	195	170	377	173	405	2A	10730
HZ14-A0	1400/500	600	360-1420	240-1300	870	750	1080	1200 x 100 x 40	600	195	170	379	172	415	2A	11160
HZ18-A0	1800/500	600	300-1520	180-1400	1050	750	1085	1200 x 130 x 40	600	185	175	386	135	490	2A	11830

Options

	RRP
	Euro
2 hydraulic functions – Integrated sideshifter	630
Separate sideshifter: 100 + 100 mm for ISO/FEM 2	1330
2 hydraulic functions – Independent arm control	965
Class 2 quick-release lower mountings	605

Available on request

- Contact pads for different drums
- Dual pivoting contact pads for plastic drum
- Other opening ranges

Advantages

- Expertly manufactured
- Superior mechanical strength
- This equipment can be used both to move drums and to move loads as if it were a fork clamp

Pallet inverter clamp 360°

HI

1400 kg
2600 kg

Product info

- 360° rotation
- Continuous rotation in both directions
- Fast rotation and high torque
- W6 – Minimum carriage width
- Exclusive synchronised loading system
- Mounting angle 0°
- Welded forks
- Without sideshifter

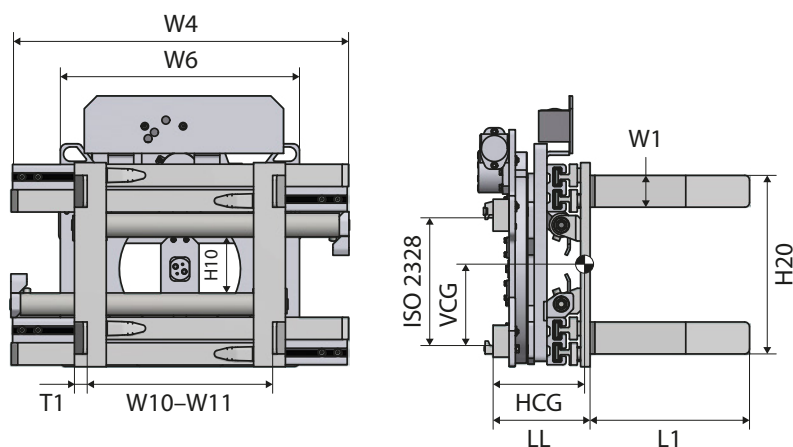

Model	Capacity	W10–W11	W4	W6	H20	Forks L1 x W1 x T1	H10	LL	HCG	VCG	Weight	ISO 2328	RRP
	kg/mm												mm
HI14-A0-10	1400/500	570–1890	1050	750	560	1000 x 100 x 40	195	298	270	279	625	2A	16870
HI18-A0-10	1800/500	550–1970	1150	750	560	1000 x 120 x 45	185	301	295	284	645	2A	17870
HI22-A0-12	2200/500	540–1960	1150	750	560	1200 x 150 x 50	180	301	351	316	801	2A	19650
HI26-A0-12	2600/500	610–2030	1150	900	560	1200 x 150 x 50	175	307	295	287	850	3A	20540

Options

	RRP
	Euro
Separate sideshifter: 100 + 100 mm for ISO/FEM 2	1330
Separate sideshifter: 100 + 100 mm for ISO/FEM 3	1800
Quick-release lower mountings, class 2 or class 3	605

Available on request

- Bolted forks
- Fixed or hydraulic side loading plate
- Different opening and fork sizes

Advantages

- Expertly manufactured
- Superior mechanical strength
- Excellent arm carriers synchrony
- Increased lifting capacity by strength multiplier circuit

HY**1400 kg
1800 kg**

Load clamps for foam rubber blocks

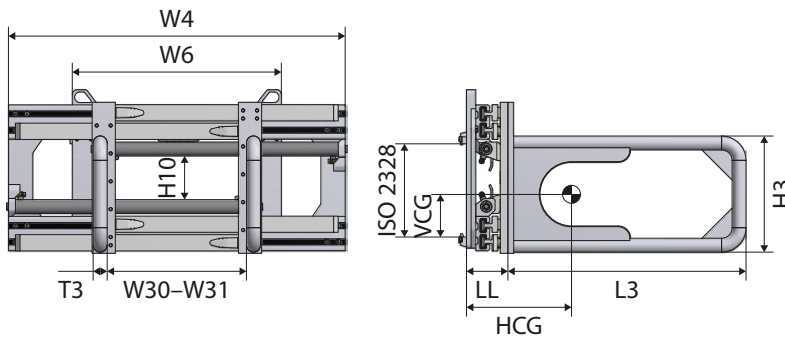

Product info

- Arm design with steel tubes to avoid damage to the load
- Block valve with flow divider for excellent arms synchronization
- Pressure-regulating valve
- Excellent visibility through the frame
- W6 – Minimum carriage width
- Without sidershifter
- Opening range measured across rear of the arms
- Bolted arms



Model	Capacity	W30–W31	W4	W6	Arms L3 x H3 x T3	H10	LL	HCG	VCG	Weight	ISO 2328	RRP
	kg/mm											mm
HY14-A0-18	1400/500	590–2310	1450	950	1800 x 500 x 60	195	125	324	236	486	2A	8780
HY20-A0-20	1800/500	630–2300	1450	950	2000 x 550 x 60	185	135	336	211	515	2A	9820

Options

	RRP
	Euro
Separate sidershifter: 100 + 100 mm for ISO/FEM 2	1330
Quick-release lower mountings, class 2	605
2 hydraulic functions – Independent arm control	640
2 hydraulic functions – Integrated sidershifting	630
Double max. pressure control valve	685
Frame bumper	260

Available on request

- Different arm dimensions
- Other opening ranges
- Manometer

Technical data

Clamps

Model	Clamping						Sideshifting						Hydraulic functions
	Operating pressure			Oil flow rate			Operating pressure			Oil flow rate			
	Min.	Recom- mended	Max.	Min.	Recom- mended	Max.	Min.	Recom- mended	Max.	Min.	Recom- mended	Max.	
H	80	160	180	15	25	40	–	–	–	–	–	–	1
HF10T – HF18T	80	160	180	15	25	40	130	160	220	4	10	15	2
HF22T	80	160	180	15	25	40	130	160	220	6	12	20	2
HF26T – HF40T	100	160	180	18	30	45	130	160	220	7	14	20	2
HF45T	100	160	180	18	25	55	130	160	220	7	14	25	2
HP10T – HP22T	80	160	180	15	25	40	130	160	220	4	10	15	2
HP26T – HP30T	100	160	180	18	25	45	130	160	220	6	12	20	2
HY14 – HY20	80	160	180	15	25	45	–	–	–	–	–	–	1
HXT	80	160	180	15	25	45	130	160	220	7	14	20	2
HOX	80	160	180	15	25	45	–	–	–	–	–	–	1
HD	80	160	180	15	25	45	–	–	–	–	–	–	1
HZ	80	160	180	15	25	45	–	–	–	–	–	–	1

Model	Clamping						Rotating						Hydraulic functions
	Operating pressure			Oil flow rate			Operating pressure			Oil flow rate			
	Min.	Recom- mended	Max.	Min.	Recom- mended	Max.	Min.	Recom- mended	Max.	Min.	Recom- mended	Max.	
HR10 – HR22	80	160	180	15	25	40	130	160	180	20	30	40	2
HR26	80	160	180	18	25	40	130	160	180	20	35	45	2
HR30 – HR40	100	160	180	18	30	45	130	160	180	25	40	65	2
HR45	100	160	180	18	25	55	130	160	180	25	40	65	2
HFR10 – HFR18	80	160	180	15	25	40	130	160	180	20	30	40	2
HFR22	80	160	180	15	25	40	130	160	180	20	35	45	2
HFR26 – HFR40	100	160	180	18	30	45	130	160	180	25	40	65	2
HFR45	100	160	180	18	25	55	130	160	180	25	40	65	2
HI14 – HI18	80	160	180	15	25	40	130	160	180	20	30	40	2
HI22	80	160	180	15	25	40	130	160	180	20	35	45	2
HI26	100	160	180	15	25	45	130	160	180	25	40	65	2
HPR10 – HPR 22	80	160	180	15	25	40	130	160	180	20	30	40	2
HPR26	100	160	180	18	25	40	130	160	180	20	35	45	2
HDR	80	160	180	15	25	45	130	160	180	20	30	40	2



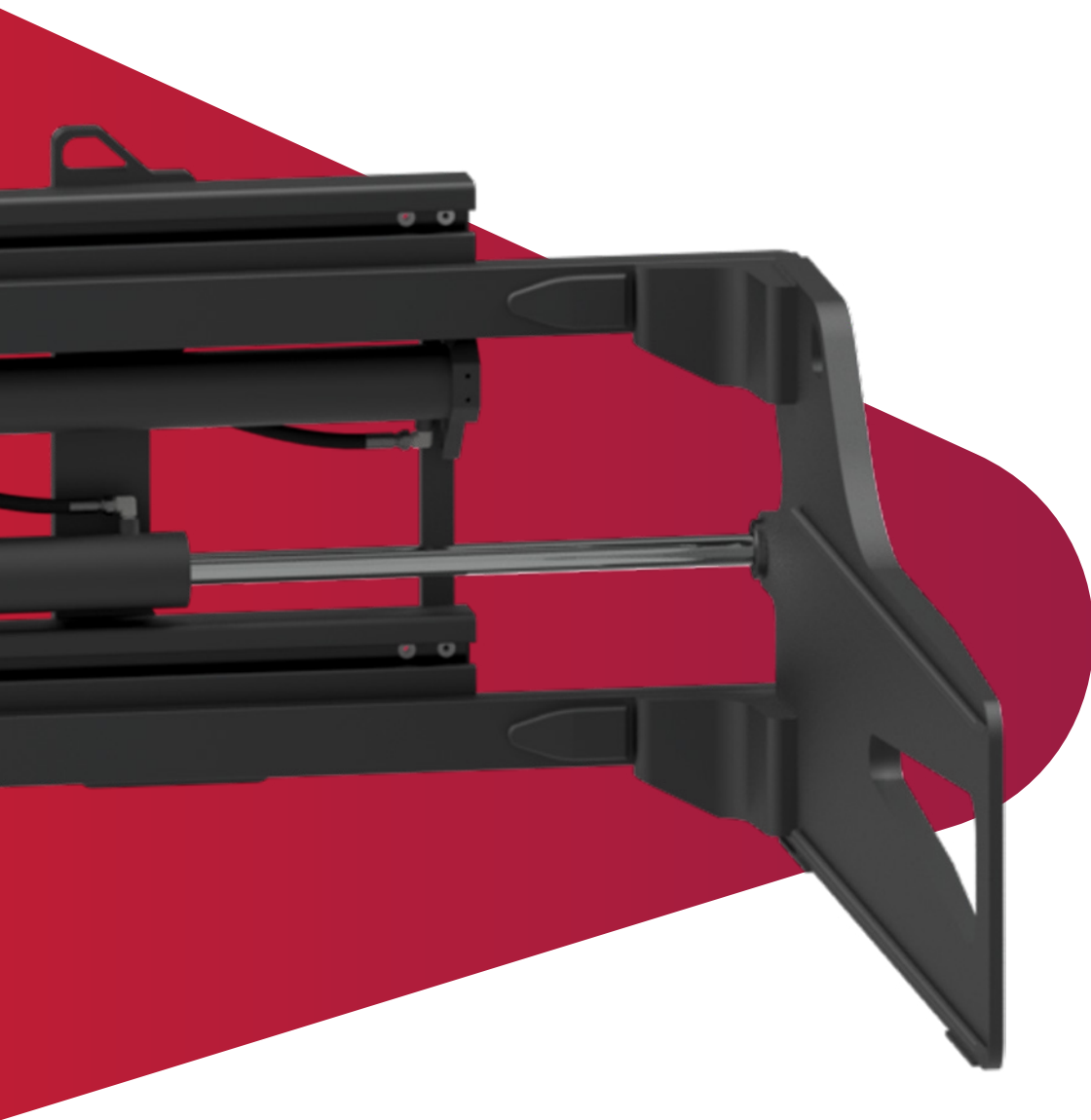

7. Bale clamps

Bale clamps are designed to clamp baled materials such as waste paper, recycled plastic products, textile rags, natural and synthetic textile fibres, and more.

HB-T

1000 kg
1900 kg

Bale clamps

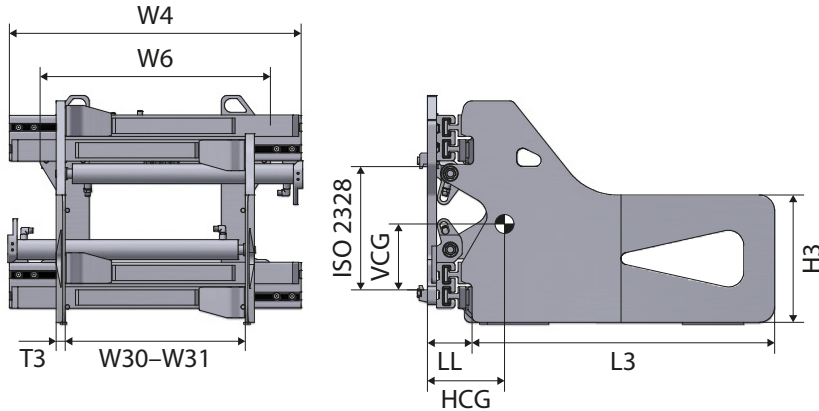

Product info

- W6 – Minimum carriage width
- With retaining and pressure relief valve
- With flow divider
- With valve block sideshifter



Model	Capacity	W30–W31*	W4	W6	Arms L3 x H3 x T3	H10	LL	HCG	VCG	Weight	ISO 2328	RRP
	kg/mm											mm
HB10-AOT-09	1000/500	445–1585	950	750	900 x 400 x 25	195	125	232	217	373	2A	6800
HB10-AOT-10	1000/500	440–1580	950	750	1000 x 400 x 25	195	125	259	213	390	2A	6920
HB10-A1T-09	1000/500	545–1785	950	750	900 x 400 x 25	195	125	230	217	379	2A	6800
HB10-A1T-10	1000/500	540–1780	950	750	1000 x 400 x 25	195	125	259	213	397	2A	6920
HB14-AQOT-10	1400/500	440–1580	950	750	1000 x 400 x 25	195	125	264	210	393	2A	7460
HB14-AQOT-12	1400/500	430–1570	950	750	1200 x 400 x 25	195	125	262	216	427	2A	7750
HB14-AOT-09	1400/500	555–1790	950	750	900 x 400 x 25	195	125	234	217	380	2A	7200
HB14-AOT-10	1400/500	550–1790	950	750	1000 x 400 x 25	195	125	265	211	398	2A	7460
HB14-BOT-09	1400/500	445–1685	1050	750	900 x 400 x 25	195	125	231	218	386	2A	7550
HB14-BOT-10	1400/500	440–1680	1050	750	1000 x 400 x 25	195	125	251	216	404	2A	7790
HB14-BQOT-10	1400/500	540–1880	1050	750	1000 x 400 x 30	195	125	230	217	409	2A	7790
HB14-BQOT-12	1400/500	530–1870	1050	750	1200 x 400 x 25	195	125	265	223	425	2A	8110
HB14-COT-09	1400/500	455–1795	1150	750	900 x 400 x 25	195	125	223	218	393	2A	7880
HB14-COT-10	1400/500	450–1790	1150	750	1000 x 400 x 25	195	125	250	212	410	2A	8110
HB14-C1T-09	1400/500	655–2195	1150	750	900 x 400 x 25	195	125	221	219	408	2A	7880
HB14-C1T-10	1400/500	650–2190	1150	750	1000 x 400 x 25	195	125	248	213	426	2A	8110
HB18-AOT-10	1900/500	550–1770	950	750	1000 x 400 x 30	185	135	251	214	427	2A	7820
HB18-AOT-12	1900/500	540–1760	950	750	1200 x 400 x 30	185	135	325	203	468	2A	7960
HB18-BOT-10	1900/500	450–1670	1050	750	1000 x 400 x 30	185	135	253	215	432	2A	8140
HB18-BOT-12	1900/500	440–1660	1050	750	1200 x 400 x 30	185	135	300	206	455	2A	8310
HB18-BQOT-10	1900/500	580–1930	1050	824	1000 x 400 x 30	185	135	252	214	437	2A	8140
HB18-BQOT-12	1900/500	570–1920	1050	824	1200 x 400 x 30	185	135	299	205	465	2A	8310
HB18-CQOT-10	1900/500	480–1830	1150	824	1000 x 400 x 30	185	135	244	217	443	2A	8360
HB18-CQOT-12	1900/500	470–1820	1150	824	1200 x 400 x 30	185	135	298	208	470	2A	8460
HB18-COT-10	1900/500	560–1980	1150	750	1000 x 400 x 30	185	135	249	216	433	2A	8510
HB18-COT-12	1900/500	550–1970	1150	750	1200 x 400 x 30	185	135	297	207	474	2A	8650
HB18-DOT-10	1900/500	450–1870	1250	820	1000 x 400 x 30	185	135	242	217	448	2A	8840
HB18-DOT-12	1900/500	440–1860	1250	820	1200 x 400 x 30	185	135	292	209	487	2A	8970
HB18-DQOT-12	1900/500	630–2260	1250	824	1200 x 400 x 30	185	135	290	208	493	2A	8970

* Opening range measured across arm tips

Bale clamps

HB-T

2300 kg

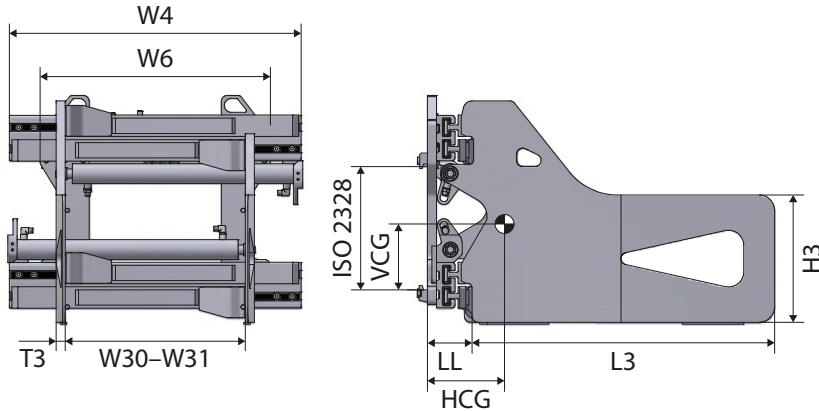

Product info

- W6 – Minimum carriage width
- With retaining and pressure relief valve
- With flow divider
- With valve block sideshifter



Model	Capacity	W30–W31*	W4	W6	Arms L3 x H3 x T3	H10	LL	HCG	VCG	Weight	ISO 2328	RRP
	kg/mm											mm
HB22-AQ0T-10	2300/500	450–1580	950	820	1000 x 400 x 30	180	135	251	217	410	2A**	8330
HB22-AQ0T-12	2300/500	440–1570	950	820	1200 x 400 x 30	180	135	324	205	466	2A**	8480
HB22-A0T-10	2300/500	580–1840	950	750	1000 x 400 x 30	180	135	250	216	415	2A**	8330
HB22-A0T-12	2300/500	570–1830	950	750	1200 x 400 x 30	180	135	323	204	471	2A**	8480
HB22-BU0T-10	2300/500	480–1740	1050	750	1000 x 400 x 30	180	135	246	215	419	2A**	8700
HB22-BU0T-12	2300/500	470–1730	1050	750	1200 x 400 x 30	180	135	318	204	475	2A**	8860
HB22-BU1T-10	2300/500	540–1860	1050	750	1000 x 400 x 30	180	135	247	216	424	2A**	8830
HB22-BU1T-12	2300/500	530–1850	1050	750	1200 x 400 x 30	180	135	319	204	498	2A**	8990
HB22-B0T-10	2300/500	650–2070	1050	750	1000 x 400 x 30	180	135	248	216	429	2A**	8700
★ HB22-B0T-12	2300/500	640–2060	1050	750	1200 x 400 x 30	180	135	315	205	485	2A**	8860
HB22-C0T-10	2300/500	550–1970	1150	750	1000 x 400 x 30	180	135	245	215	434	2A**	9070
HB22-C0T-12	2300/500	540–1960	1150	750	1200 x 400 x 30	180	135	315	202	490	2A**	9240
HB22-DU0T-10	2300/500	480–1930	1250	820	1000 x 400 x 30	180	135	242	215	447	2A**	9600
HB22-D0T-10	2300/500	590–2130	1250	820	1000 x 400 x 30	180	135	242	214	452	2A**	9470
HB22-D0T-12	2300/500	580–2120	1250	820	1200 x 400 x 30	180	135	303	209	512	2A**	9600
HB22-HU0T-10	2300/500	500–2040	1320	820	1000 x 400 x 30	180	135	310	200	467	2A**	9610
HB22-HQ0T-12	2300/500	580–2220	1320	820	1200 x 400 x 30	180	135	242	214	477	2A**	9770

★ Suggested selection

* Opening range measured across arm tips

** Available on request mounting class 3A

Options

	RRP
	Euro
Separate sideshifter: 100 + 100 mm for ISO/FEM 2	1330
Hydraulic functions – Independent arm control	640
Quick-release lower mountings, class 2 or class 3	605
Frame bumper	260
Gripper teeth	260
Wear strips under arms	395
Wear strips under frame	520

Available on request

- Different arm dimensions
- Class B mounting arms
- Load backrest
- Models without sideshifter
- Manometer
- Other opening ranges
- Models with arms without holes

HB-T

2600 kg
3000 kg

Bale clamps

Product info

- W6 – Minimum carriage width
- With retaining and pressure relief valve
- With flow divider
- With valve block sideshifter

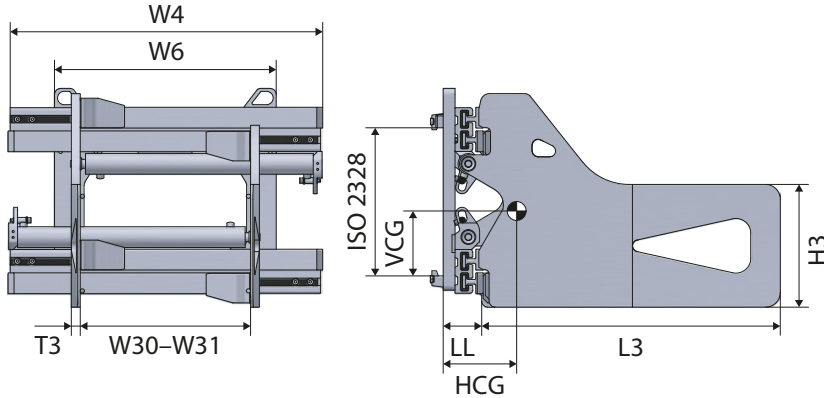

Model	Capacity	W30–W31*	W4	W6	Arms L3 x H3 x T3	H10	LL	HCG	VCG	Weight	ISO 2328	RRP
	kg/mm											mm
HB26-AU03T-10	2600/500	480–1740	1050	750	1000 x 400 x 30	180	145	268	234	437	3A	9600
HB26-AU03T-12	2600/500	470–1730	1050	750	1200 x 400 x 30	180	145	313	210	489	3A	9360
HB26-A03T-10	2600/500	540–1860	1050	750	1000 x 400 x 30	180	145	269	235	442	3A	9600
HB26-A03T-12	2600/500	530–1850	1050	750	1200 x 400 x 30	180	145	313	210	494	3A	9800
HB26-BQ03T-10	2600/500	550–1970	1150	750	1000 x 400 x 30	180	145	262	234	451	3A	9600
HB26-BQ03T-12	2600/500	540–1960	1150	750	1200 x 400 x 30	180	145	301	211	511	3A	9800
HB26-B03T-10	2600/500	670–1990	1150	750	1000 x 400 x 30	180	145	263	235	456	3A	9600
HB26-B03T-12	2600/500	660–2200	1150	750	1200 x 400 x 30	180	145	301	211	516	3A	9800
HB26-CQ03T-12	2600/500	440–1830	1250	820	1200 x 400 x 30	180	145	303	212	510	3A	10240
HB26-CQ13T-10	2600/500	660–2300	1250	820	1000 x 400 x 30	180	145	258	236	474	3A	9990
HB26-C03T-10	2600/500	540–2030	1250	820	1000 x 400 x 30	180	145	259	235	469	3A	9990
HB26-C03T-12	2600/500	530–2020	1250	820	1200 x 400 x 30	180	145	290	212	540	3A	10240
HB26-CQ13T-12	2600/500	650–2290	1250	820	1200 x 400 x 30	180	145	289	212	546	3A	10240
HB26-DU03T-10	2600/500	500–2040	1320	820	1000 x 400 x 30	180	145	249	234	472	3A	10090
HB26-D03T-10	2600/500	670–2320	1320	820	1000 x 400 x 30	180	145	229	219	490	3A	10090
HB26-D03T-12	2600/500	660–2310	1320	820	1200 x 400 x 30	180	145	285	213	566	3A	10230
HB26-FQ03T-12	2600/500	600–2400	1450	820	1200 x 400 x 30	180	145	285	213	576	3A	10560
HB30-AQ0T-10	3000/500	560–1950	1150	870	1000 x 400 x 35	175	156	261	316	681	3A	10010
HB30-AQ0T-12	3000/500	540–1940	1150	870	1200 x 400 x 35	175	156	314	293	724	3A	10280
★ HB30-A0T-12	3000/500	620–2090	1150	870	1200 x 400 x 35	175	156	306	277	802	3A	10280
HB30-A0T-14	3000/500	610–2080	1150	870	1400 x 400 x 35	175	156	365	252	845	3A	10580
HB30-B0T-12	3000/500	520–1980	1250	870	1200 x 400 x 35	175	156	300	278	806	3A	10400
HB30-B0T-14	3000/500	510–1970	1250	870	1400 x 400 x 35	175	156	353	253	849	3A	10760
HB30-CQ0T-10	3000/500	560–2150	1320	870	1000 x 400 x 35	175	156	245	300	776	3A	10600
HB30-CQ0T-12	3000/500	550–2130	1320	870	1200 x 400 x 35	175	156	298	277	819	3A	10860
HB30-C0T-12	3000/500	640–2300	1320	870	1200 x 400 x 35	175	156	299	278	824	3A	10860
HB30-C0T-14	3000/500	630–2290	1320	870	1400 x 400 x 35	175	156	345	253	864	3A	11220
HB30-DQ0T-12	3000/500	610–2380	1450	870	1200 x 400 x 35	175	156	295	275	832	3A	11200

★ Suggested selection

* Opening range measured across arm tips

Bale clamps

HB-T

3500 kg

Product info

- W6 – Minimum carriage width
- With retaining and pressure relief valve
- With flow divider
- With valve block sideshifter

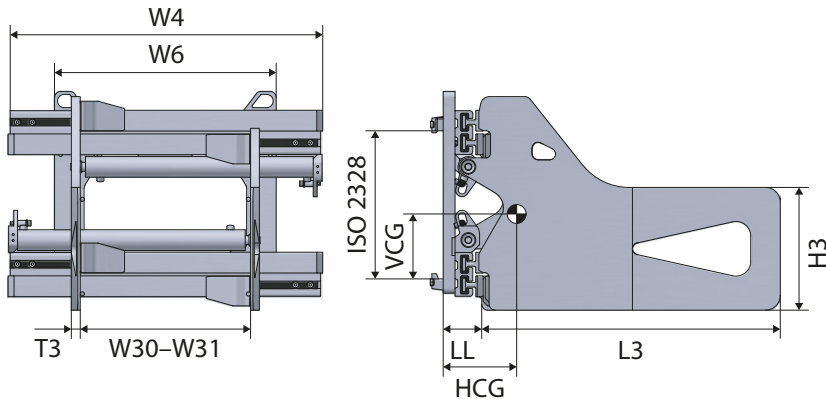

Model	Capacity	W30–W31*	W4	W6	Arms L3 x H3 x T3	H10	LL	HCG	VCG	Weight	ISO 2328	RRP
	kg/mm											mm
HB35-A0T-12	3500/500	440–1740	1150	870	1200 x 400 x 35	170	156	306	277	762	3A**	10620
HB35-A0T-14	3500/500	430–1730	1150	870	1400 x 400 x 35	170	156	365	252	805	3A**	10970
HB35-AQ0T-10	3500/500	550–1950	1150	870	1000 x 400 x 35	170	156	254	301	724	3A**	10350
HB35-AQ0T-12	3500/500	540–1940	1150	870	1200 x 400 x 35	170	156	307	278	767	3A**	10620
HB35-DQ0T-10	3500/500	450–1850	1250	870	1000 x 400 x 35	170	156	249	299	753	3A**	10580
HB35-DQ0T-12	3500/500	440–1840	1250	870	1200 x 400 x 35	170	156	302	276	796	3A**	10840
HB35-DU0T-10	3500/500	530–2000	1250	870	1000 x 400 x 35	170	156	252	299	758	3A**	10800
HB35-DU0T-12	3500/500	520–1990	1250	870	1200 x 400 x 35	170	156	305	276	801	3A**	11070
HB35-DU1T-10	3500/500	600–2150	1250	870	1000 x 400 x 35	170	156	252	298	761	3A**	11020
HB35-DU1T-12	3500/500	590–2140	1250	870	1200 x 400 x 35	170	156	304	275	804	3A**	11290
HB35-BQ0T-12	3500/500	540–2130	1320	870	1200 x 400 x 35	170	156	304	277	825	3A**	11510
HB35-B0T-12	3500/500	700–2430	1320	870	1200 x 400 x 35	170	156	302	276	835	3A**	11170
HB35-B0T-14	3500/500	690–2420	1320	870	1400 x 400 x 35	170	156	361	251	875	3A**	11490
HB35-C0T-12	3500/500	570–2300	1450	920	1200 x 400 x 35	170	156	296	275	842	3A**	11490
HB35-C0T-14	3500/500	560–2290	1450	920	1400 x 400 x 35	170	156	361	250	883	3A**	11780
HB35-CQ0T-12	3500/500	640–2440	1450	920	1200 x 400 x 35	170	156	297	276	847	3A**	11490

* Opening range measured across arm tips

** Available on request mounting class 4A

Options

	RRP
	Euro
Separate sideshifter: 100 + 100 mm for ISO/FEM 3	1800
Hydraulic functions – Independent arm control	640
Quick-release lower mountings, class 3	605
Frame bumper	260
Gripper teeth	260
Wear strips under arms	395
Wear strips under frame	520

Available on request

- Different arm dimensions
- Class B mounting arms
- Load backrest
- Models without sideshifter
- Manometer
- Other opening ranges
- Models with arms without holes

HB-T

4200 kg
4500 kg

Bale clamps

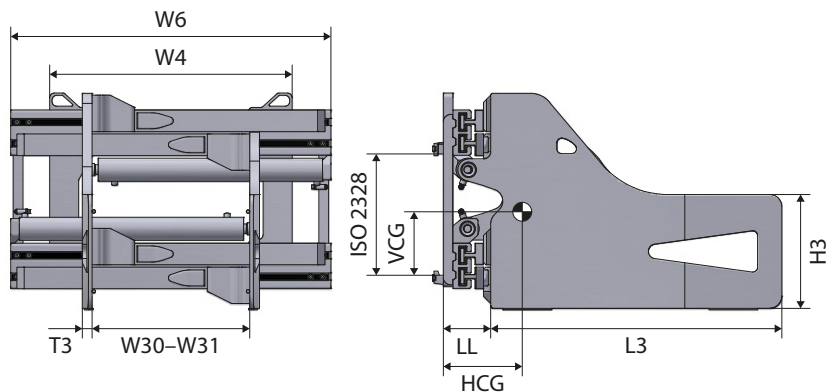

Product info

- W6 – Minimum carriage width
- With retaining and pressure relief valve
- With flow divider
- With valve block sideshifter
- Valve with regenerative circuit
- Valve with performance sideshifting control



Model	Capacity	W30–W31*	W4	W6	Arms L3 x H3 x T3	H10	LL	HCG	VCG	Weight	ISO 2328	RRP
	kg/mm											mm
HB42-A0T-12	4200/500	630–2070	1150	870	1200 x 450 x 40	165	156	340	251	861	3A**	11500
HB42-A0T-14	4200/500	620–2060	1150	870	1400 x 450 x 40	165	156	387	244	908	3A**	11740
HB42-A0T-16	4200/500	610–2050	1150	870	1600 x 450 x 40	165	156	434	238	956	3A**	12010
HB42-GQ0T-12	4200/500	540–2010	1250	870	1200 x 450 x 40	165	156	330	226	848	3A**	11690
HB42-GQ0T-14	4200/500	530–2000	1250	870	1400 x 450 x 40	165	156	375	232	949	3A**	12000
HB42-GQ0T-16	4200/500	520–1990	1250	870	1600 x 450 x 40	165	156	425	239	982	3A**	12250
HB42-B0T-12	4200/500	590–2160	1320	870	1200 x 450 x 40	165	156	321	255	901	3A**	11680
HB42-B0T-14	4200/500	580–2150	1320	870	1400 x 450 x 40	165	156	368	248	975	3A**	11940
HB42-B0T-16	4200/500	570–2140	1320	870	1600 x 450 x 40	165	156	418	241	1008	3A**	12200
HB42-CQ0T-16	4200/500	430–2000	1450	920	1600 x 450 x 40	165	156	401	242	1040	3A**	12470
HB42-C0T-12	4200/500	690–2510	1450	920	1200 x 450 x 40	165	156	313	257	964	3A**	11940
HB42-C0T-14	4200/500	680–2500	1450	920	1400 x 450 x 40	165	156	366	247	1015	3A**	12210
HB42-C0T-16	4200/500	670–2490	1450	920	1600 x 450 x 40	165	156	402	244	1047	3A**	12470
HB42-HQ0T-16	4200/500	550–2500	1700	920	1600 x 450 x 40	165	156	395	238	1080	3A**	13150
HB45-A0T-12	4500/600	610–2330	1450	1050	1200 x 500 x 40	210	191	314	282	1022	4A	15980
HB45-A0T-14	4500/600	600–2320	1450	1050	1400 x 500 x 40	210	191	365	274	1077	4A	16280
HB45-A0T-16	4500/600	590–2310	1450	1050	1600 x 500 x 40	210	191	400	264	1120	4A	16590
HB45-B0T-12	4500/600	700–2670	1600	1050	1200 x 500 x 40	210	191	300	284	1052	4A	16480
HB45-B0T-14	4500/600	690–2660	1600	1050	1400 x 500 x 40	210	191	352	278	1120	4A	16590
HB45-B0T-16	4500/600	680–2650	1600	1050	1600 x 500 x 40	210	191	396	268	1190	4A	16950

* Opening range measured across arm tips

** Available on request mounting class 4A

Bale clamps

HB-T

4200 kg
4500 kg

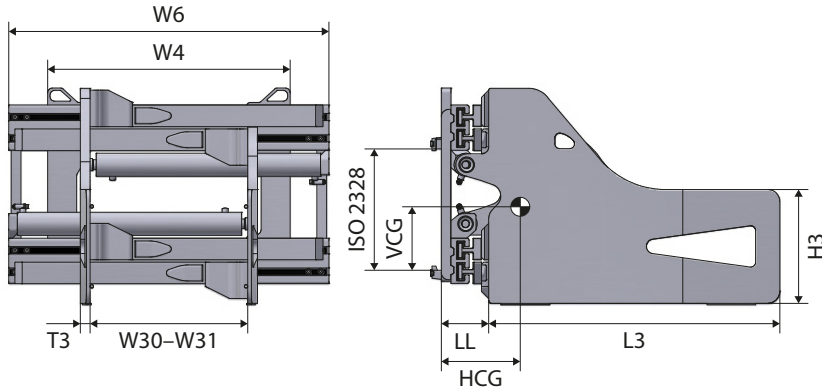

Product info

- W6 – Minimum carriage width
- With retaining and pressure relief valve
- With flow divider
- With valve block sideshifter
- Valve with regenerative circuit
- Valve with performance sideshifting control

Options

	RRP
	Euro
Separate sideshifter: 100 + 100 mm for ISO/FEM 3	1800
Separate sideshifter: 100 + 100 mm for ISO/FEM 4	2140
2 hydraulic functions – Independent arm control	640
Quick-release lower mountings, class 3	605
Quick-release lower mountings, class 4	810
Frame bumper	260
Gripper teeth	260
Wear strips under arms	395
Wear strips under frame	520

Available on request

- Different arm dimensions
- Class B mounting arms
- Load backrest
- Models without sideshifter
- Manometer
- Other opening ranges
- Models with arms without holes

See this attachment in action



Advantages

- Fully protected valve and high-grade steel for long life
- Synchronised arm movements
- Excellent load grip
- Expertly manufactured
- High piston rods durability thanks to improved pistons joints
- Increased manoeuvrability in confined spaces
- Greater versatility

HB-T
CDW.01

1900 kg

Recycling clamps

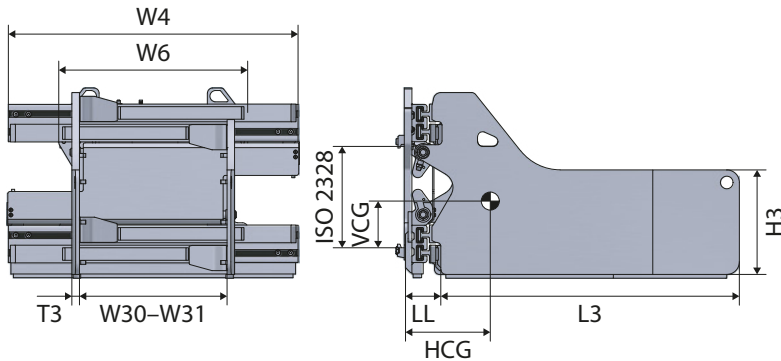

Product info

- W6 – Minimum carriage width
- With retaining and pressure relief valve
- With flow divider
- With valve block sidsifter
- With frame bumper
- With gripper teeth
- With wear strips under arms
- With wear strips under frame



Model	Capacity	W30–W31*	W4	W6	Arms L3 x H3 x T3	H10	LL	HCG	VCG	Weight	ISO 2328	RRP
	kg/mm											mm
HB18-AQ0T-10.CDW.01	1900/500	440–1570	950	750	1000 x 400 x 30	185	135	287	195	483	2A	9800
HB18-AQ0T-12.CDW.01	1900/500	430–1560	950	750	1200 x 400 x 30	185	135	352	186	548	2A	9850
HB18-A0T-10.CDW.01	1900/500	550–1770	950	750	1000 x 400 x 30	185	135	286	196	488	2A	9800
HB18-A0T-12.CDW.01	1900/500	540–1760	950	750	1200 x 400 x 30	185	135	351	185	553	2A	9850
HB18-B0T-10.CDW.01	1900/500	450–1670	1050	750	1000 x 400 x 30	185	135	279	197	503	2A	10040
HB18-B0T-12.CDW.01	1900/500	440–1660	1050	750	1200 x 400 x 30	185	135	326	188	540	2A	10280
HB18-BQ0T-10.CDW.01	1900/500	580–1930	1050	750	1000 x 400 x 30	185	135	278	196	508	2A	10040
HB18-BQ0T-12.CDW.01	1900/500	570–1920	1050	750	1200 x 400 x 30	185	135	325	187	545	2A	10280
HB18-C0T-10.CDW.01	1900/500	560–1980	1150	750	1000 x 400 x 30	185	135	275	198	518	2A	10500
HB18-C0T-12.CDW.01	1900/500	550–1970	1150	750	1200 x 400 x 30	185	135	323	189	559	2A	10420
HB18-D0T-10.CDW.01	1900/500	450–1870	1250	820	1000 x 400 x 30	185	135	268	199	523	2A	10710
HB18-D0T-12.CDW.01	1900/500	440–1860	1250	820	1200 x 400 x 30	185	135	318	191	568	2A	10850
HB18-DQ0T-12.CDW.01	1900/500	570–2130	1250	820	1200 x 400 x 30	185	135	317	190	573	2A	10850

* Opening range measured across arm tips

Options

	RRP
	Euro
Separate sidsifter: 100 + 100 mm for ISO/FEM 3	1800
Hydraulic functions – Independent arm control	640
Quick-release lower mountings, class 2	605

Available on request

- Different arm dimensions
- Class B mounting arms
- Load backrest (see page 20)
- Models without sidsifter
- Manometer
- Other opening ranges
- Models with arms without holes

Recycling clamps

HB-T
CDW.01

2300 kg

Product info

- W6 – Minimum carriage width
- With retaining and pressure relief valve
- With flow divider
- With valve block sideshifter
- With frame bumper
- With gripper teeth
- With wear strips under arms
- With wear strips under frame

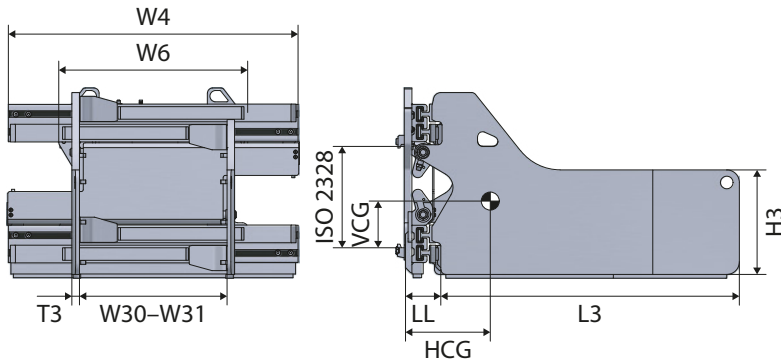

Model	Capacity	W30–W31*	W4	W6	Arms L3 x H3 x T3	H10	LL	HCG	VCG	Weight	ISO 2328	RRP
	kg/mm											mm
HB22-AQ0T-10.CDW.01	2300/500	440–1570	950	750	1000 x 400 x 30	180	135	277	199	495	2A**	10240
HB22-AQ0T-12.CDW.01	2300/500	450–1580	950	750	1200 x 400 x 30	180	135	350	187	551	2A**	10240
HB22-A0T-10.CDW.01	2300/500	580–1840	950	750	1000 x 400 x 30	180	135	276	198	500	2A**	10240
HB22-A0T-12.CDW.01	2300/500	570–1830	950	750	1200 x 400 x 30	180	135	349	186	556	2A**	10240
HB22-BQ0T-10.CDW.01	2300/500	430–1650	1050	750	1000 x 400 x 30	180	135	276	196	504	2A**	10460
HB22-BQ0T-12.CDW.01	2300/500	440–1660	1050	750	1200 x 400 x 30	180	135	343	183	560	2A**	10620
HB22-B0T-10.CDW.01	2300/500	670–2090	1050	750	1000 x 400 x 30	180	135	274	198	514	2A**	10460
HB22-B0T-12.CDW.01	2300/500	660–2080	1050	750	1200 x 400 x 30	180	135	346	185	570	2A**	10620
HB22-C0T-10.CDW.01	2300/500	550–1970	1150	750	1000 x 400 x 30	180	135	271	197	519	2A**	10940
HB22-C0T-12.CDW.01	2300/500	540–1960	1150	750	1200 x 400 x 30	180	135	341	184	575	2A**	11010
HB22-D0T-10.CDW.01	2300/500	590–2130	1250	820	1000 x 400 x 30	180	135	268	196	537	2A**	11210
HB22-D0T-12.CDW.01	2300/500	580–2120	1250	820	1200 x 400 x 30	180	135	338	183	593	2A**	11360
HB22-EQ0T-12.CDW.01	2300/500	610–2280	1320	820	1200 x 400 x 30	180	135	335	182	615	2A**	11570
HB22-FU0T-10.CDW.01	2300/500	610–2410	1450	820	1000 x 400 x 30	180	135	267	195	579	2A**	11630
HB22-FU0T-12.CDW.01	2300/500	600–2400	1450	820	1200 x 400 x 30	180	135	333	180	635	2A**	11880

* Opening range measured across arm tips

** Available on request mounting class 3A

Options

	RRP
	Euro
Separate sideshifter: 100 + 100 mm for ISO/FEM 2	1330
Separate sideshifting 100 + 100 mm for ISO/FEM 3	1800
2 hydraulic functions – Independent arm control	640
Quick-release lower mountings, class 2	605

Available on request

- Different arm dimensions
- Class B mounting arms
- Load backrest
- Models without sideshifter
- Manometer
- Other opening ranges

See this attachment in action



**HB-T
CDW.01**

**2600 kg
3000 kg**

Recycling clamps

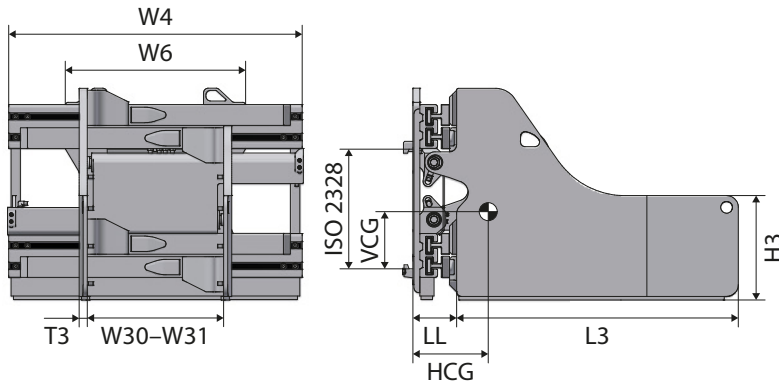

Product info

- W6 – Minimum carriage width
- With retaining and pressure relief valve
- With flow divider
- With valve block sideshifter
- With frame bumper
- With gripper teeth
- With wear strips under arms
- With wear strips under frame



Model	Capacity	W30–W31*	W4	W6	Arms L3 x H3 x T3	H10	LL	HCG	VCG	Weight	ISO 2328	RRP
	kg/mm											mm
HB26-AQ03T-10.CDW.01	2600/500	590–1960	1050	750	1000 x 400 x 30	180	145	278	203	548	3A	11720
HB26-AQ03T-12.CDW.01	2600/500	580–1950	1050	750	1200 x 400 x 30	180	145	301	173	573	3A	11900
HB26-B03T-10.CDW.01	2600/500	680–2210	1150	750	1000 x 400 x 30	180	145	277	202	567	3A	12100
HB26-B03T-12.CDW.01	2600/500	670–2200	1150	750	1200 x 400 x 30	180	145	302	172	592	3A	12270
HB26-BQ03T-10.CDW.01	2600/500	550–1980	1150	750	1000 x 400 x 30	180	145	274	203	562	3A	12100
HB26-BQ03T-12.CDW.01	2600/500	540–1960	1150	750	1200 x 400 x 30	180	145	300	172	587	3A	12270
HB26-C03T-10.CDW.01	2600/500	540–2030	1250	820	1000 x 400 x 30	180	145	273	202	580	3A	12470
HB26-C03T-12.CDW.01	2600/500	530–2020	1250	820	1200 x 400 x 30	180	145	298	171	605	3A	12640
HB26-CQ03T-10.CDW.01	2600/500	660–2300	1250	820	1000 x 400 x 30	180	145	274	201	585	3A	12470
HB26-CQ03T-12.CDW.01	2600/500	650–2290	1250	820	1200 x 400 x 30	180	145	299	171	610	3A	12640
HB26-D03T-10.CDW.01	2600/500	670–2370	1320	820	1000 x 400 x 30	180	145	263	202	588	3A	12840
HB26-D03T-12.CDW.01	2600/500	660–2360	1320	820	1200 x 400 x 30	180	145	293	170	627	3A	12950
HB26-EQ03T-12.CDW.01	2600/500	640–2480	1450	820	1200 x 400 x 30	180	145	320	269	715	3A	13340
HB30-AQ0T-10.CDW.01	3000/500	550–1950	1150	870	1000 x 400 x 35	175	156	267	267	825	3A	11720
HB30-AQ0T-12.CDW.01	3000/500	540–1940	1150	870	1200 x 400 x 35	175	156	326	244	878	3A	12100
HB30-AQ0T-14.CDW.01	3000/500	530–1930	1150	870	1400 x 400 x 35	175	156	385	221	931	3A	12410
HB30-A0T-12.CDW.01	3000/500	630–2100	1150	870	1200 x 400 x 35	175	156	325	245	883	3A	12100
HB30-A0T-14.CDW.01	3000/500	620–2110	1150	870	1400 x 400 x 35	175	156	384	220	926	3A	12410
HB30-B0T-12.CDW.01	3000/500	520–1990	1250	870	1200 x 400 x 35	175	156	319	246	887	3A	12130
HB30-B0T-14.CDW.01	3000/500	510–1980	1250	870	1400 x 400 x 35	175	156	372	221	930	3A	12450
HB30-CQ0T-12.CDW.01	3000/500	540–2130	1320	870	1200 x 400 x 35	175	156	319	247	900	3A	12660
HB30-CQ0T-14.CDW.01	3000/500	530–2120	1320	870	1400 x 400 x 35	175	156	362	222	940	3A	12970
HB30-C0T-12.CDW.01	3000/500	640–2300	1320	870	1200 x 400 x 35	175	156	318	246	905	3A	12660
HB30-C0T-14.CDW.01	3000/500	630–2290	1320	870	1400 x 400 x 35	175	156	364	221	945	3A	12970
HB30-DQ0T-12.CDW.01	3000/500	630–2410	1450	870	1200 x 400 x 35	175	156	313	246	918	3A	12960
HB30-DQ0T-14.CDW.01	3000/500	640–2420	1450	870	1400 x 400 x 35	175	156	356	220	958	3A	13340

* Opening range measured across arm tips

Recycling clamps

**HB-T
CDW.01**

3500 kg

Product info

- W6 – Minimum carriage width
- With retaining and pressure relief valve
- With flow divider
- With valve block sideshifter
- With frame bumper
- With gripper teeth
- With wear strips under arms
- With wear strips under frame

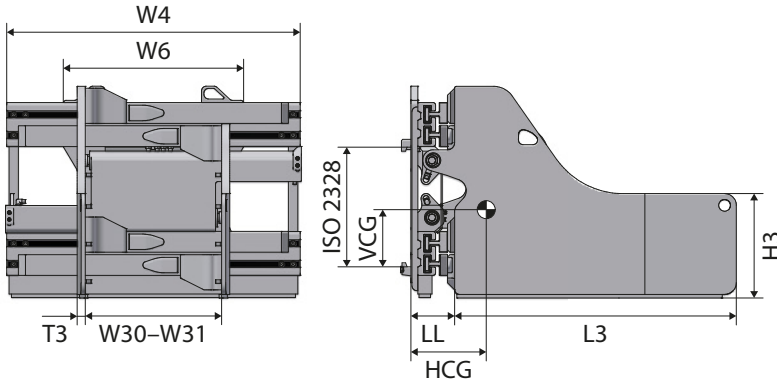

Model	Capacity	W30–W31*	W4	W6	Arms L3 x H3 x T3	H10	LL	HCG	VCG	Weight	ISO 2328	RRP
	kg/mm											mm
HB35-A0T-12.CDW.01	3500/500	440–1740	1150	870	1200 x 400 x 35	170	156	325	245	843	3A**	12290
HB35-A0T-14.CDW.01	3500/500	430–1730	1150	870	1400 x 400 x 35	170	156	384	220	886	3A**	12600
HB35-AQ0T-10.CDW.01	3500/500	550–1950	1150	870	1000 x 400 x 35	170	156	267	266	805	3A**	11980
HB35-AQ0T-12.CDW.01	3500/500	540–1940	1150	870	1200 x 400 x 35	170	156	325	246	848	3A**	12290
HB35-AQ0T-14.CDW.01	3500/500	530–1930	1150	870	1400 x 400 x 35	170	156	383	221	891	3A**	12600
HB35-DQ0T-12.CDW.01	3500/500	440–1840	1250	870	1200 x 400 x 35	170	156	324	245	880	3A**	12450
HB35-DQ0T-14.CDW.01	3500/500	430–1830	1250	870	1400 x 400 x 35	170	156	382	220	923	3A**	12820
HB35-DU0T-10.CDW.01	3500/500	530–2000	1250	870	1000 x 400 x 35	170	156	325	245	885	3A**	12180
HB35-DU0T-12.CDW.01	3500/500	520–1990	1250	870	1200 x 400 x 35	170	156	383	246	928	3A**	12440
HB35-DU1T-10.CDW.01	3500/500	600–2150	1250	870	1000 x 400 x 35	170	156	324	245	890	3A**	12200
HB35-DU1T-12.CDW.01	3500/500	590–2140	1250	870	1200 x 400 x 35	170	156	383	221	933	3A**	12440
HB35-BQ0T-12.CDW.01	3500/500	550–2130	1320	870	1200 x 400 x 35	170	156	318	243	911	3A**	12800
HB35-BQ0T-14.CDW.01	3500/500	540–2120	1320	870	1400 x 400 x 35	170	156	380	219	951	3A**	13130
HB35-B0T-12.CDW.01	3500/500	700–2430	1320	870	1200 x 400 x 35	170	156	321	244	916	3A**	12800
HB35-B0T-14.CDW.01	3500/500	690–2420	1320	870	1400 x 400 x 35	170	156	380	219	956	3A**	13130
HB35-C0T-12.CDW.01	3500/500	570–2300	1450	920	1200 x 400 x 35	170	156	315	243	923	3A**	13070
HB35-C0T-14.CDW.01	3500/500	560–2290	1450	920	1400 x 400 x 35	170	156	380	218	964	3A**	13380
HB35-CQ0T-10.CDW.01	3500/500	620–2390	1450	920	1000 x 400 x 35	170	156	266	218	885	3A**	12840
HB35-CQ0T-12.CDW.01	3500/500	610–2380	1450	920	1200 x 400 x 35	170	156	314	242	928	3A**	13070
HB35-CQ0T-14.CDW.01	3500/500	600–2370	1450	920	1400 x 400 x 35	170	156	379	217	969	3A**	13380

* Opening range measured across arm tips

** Available on request mounting class 4A

Options

	RRP
	Euro
Separate sideshifter: 100 + 100 mm for ISO/FEM 3	1800
2 hydraulic functions – Independent arm control	640
Class 3 quick-release lower mountings	605

Available on request

- Different arm dimensions
- Class B mounting arms
- Load backrest
- Models without sideshifter
- Manometer
- Other opening ranges

**HB-T
CDW.01**

4200 kg

Recycling clamps

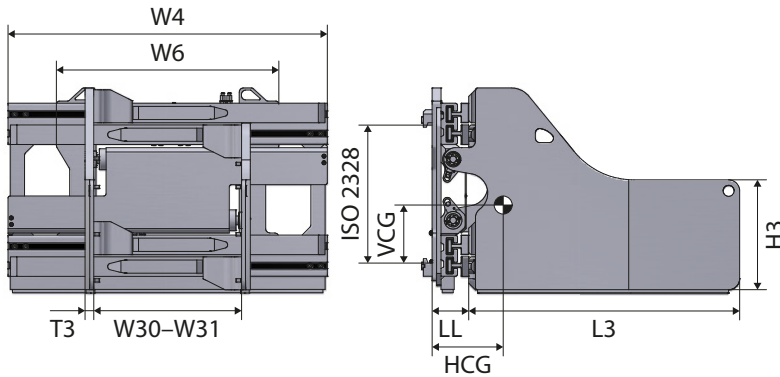

Product info

- W6 – Minimum carriage width
- With retaining and pressure relief valve
- With flow divider
- With valve block sideshifter
- Valve with regenerative circuit
- Valve with performance sideshifting control
- With frame bumper
- With gripper teeth
- With wear strips under arms
- With wear strips under frame



Model	Capacity	W30–W31*	W4	W6	Arms L3 x H3 x T3	H10	LL	HCG	VCG	Weight	ISO 2328	RRP
												Euro
HB42-AB0T-10.CDW.01	4200/500	580–1980	1150	870	1000 x 450 x 40	165	156	299	235	960	3A**	12980
HB42-AB0T-12.CDW.01	4200/500	570–1970	1150	870	1200 x 450 x 40	165	156	374	245	1008	3A**	13260
HB42-A0T-12.CDW.01	4200/500	630–2070	1150	870	1200 x 450 x 40	165	156	373	244	1013	3A**	13260
HB42-A0T-14.CDW.01	4200/500	620–2060	1150	870	1400 x 450 x 40	165	156	420	237	1060	3A**	13510
HB42-A0T-16.CDW.01	4200/500	610–2050	1150	870	1600 x 450 x 40	165	156	467	231	1108	3A**	13700
HB42-GC0T-10.CDW.01	4200/500	550–2020	1250	870	1000 x 450 x 40	165	156	300	245	980	3A**	13200
HB42-GC0T-12.CDW.01	4200/500	540–2010	1250	870	1200 x 450 x 40	165	156	365	247	1010	3A**	13460
HB42-GC0T-14.CDW.01	4200/500	530–2000	1250	870	1400 x 450 x 40	165	156	410	239	1056	3A**	13710
HB42-GC0T-16.CDW.01	4200/500	520–1990	1250	870	1600 x 450 x 40	165	156	460	233	1130	3A**	14010
HB42-B0T-10.CDW.01	4200/500	600–2170	1320	870	1000 x 450 x 40	165	156	301	250	979	3A**	13420
HB42-B0T-12.CDW.01	4200/500	590–2160	1320	870	1200 x 450 x 40	165	156	354	248	1053	3A**	13700
HB42-B0T-14.CDW.01	4200/500	580–2150	1320	870	1400 x 450 x 40	165	156	401	241	1127	3A**	13950
HB42-B0T-16.CDW.01	4200/500	570–2140	1320	870	1600 x 450 x 40	165	156	451	234	1160	3A**	13610
HB42-C0T-10.CDW.01	4200/500	700–2520	1450	920	1000 x 450 x 40	165	156	300	255	1065	3A**	13420
HB42-C0T-12.CDW.01	4200/500	690–2510	1450	920	1200 x 450 x 40	165	156	346	250	1116	3A**	13700
HB42-C0T-14.CDW.01	4200/500	680–2500	1450	920	1400 x 450 x 40	165	156	399	240	1167	3A**	13960
HB42-C0T-16.CDW.01	4200/500	670–2490	1450	920	1600 x 450 x 40	165	156	435	237	1199	3A**	14210
HB42-D0T-16.CDW.01	4200/500	590–2440	1600	1050	1600 x 450 x 40	165	156	425	231	1240	3A**	15100
HB42-HC0T-16.CDW.01	4200/500	510–2410	1700	1050	1600 x 450 x 40	165	156	420	230	1350	3A**	15290

* Opening range measured across arm tips

** Available on request mounting class 4A

Options

	RRP
	Euro
Separate sideshifter: 100 + 100 mm for ISO/FEM 3	1800
Separate sideshifter: 100 + 100 mm for ISO/FEM 4	2140
2 hydraulic functions – Independent arm control	640
Quick-release lower mountings, class 3	605
Quick-release lower mountings, class 4	810

Available on request

- Different arm dimensions
- Load backrest
- Models without sideshifter
- Manometer
- Other opening ranges

Recycling clamps

**HB-T
CDW.01**

4500 kg

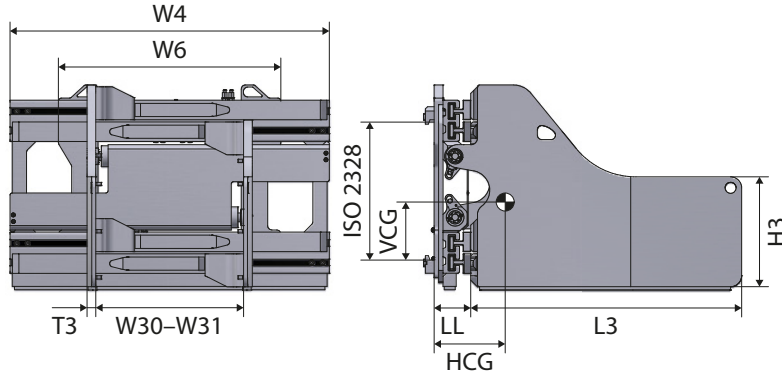

Product info

- W6 – Minimum carriage width
- With retaining and pressure relief valve
- With flow divider
- With valve block sideshifter
- Valve with regenerative circuit
- Valve with performance sideshifting control
- With frame bumper
- With gripper teeth
- With wear strips under arms
- With wear strips under frame



Model	Capacity	W30–W31*	W4	W6	Arms L3 x H3 x T3	H10	LL	HCG	VCG	Weight	ISO 2328	RRP
	kg/mm											mm
HB45-A0T-10.CDW.01	4500/600	620–2340	1450	1050	1000 x 500 x 40	210	191	299	285	1119	4A	17690
HB45-A0T-12.CDW.01	4500/600	610–2330	1450	1050	1200 x 500 x 40	210	191	347	275	1174	4A	17870
HB45-A0T-14.CDW.01	4500/600	600–2320	1450	1050	1400 x 500 x 40	210	191	398	267	1229	4A	18230
HB45-A0T-16.CDW.01	4500/600	600–2320	1450	1050	1600 x 500 x 40	210	191	444	249	1270	4A	18590
HB45-BU0T-10.CDW.01	4500/600	590–2440	1600	1050	1000 x 500 x 40	210	191	305	280	1150	4A	17890
HB45-BU0T-12.CDW.01	4500/600	580–2430	1600	1050	1200 x 500 x 40	210	191	332	276	1189	4A	18230
HB45-BU0T-14.CDW.01	4500/600	570–2420	1600	1050	1400 x 500 x 40	210	191	384	270	1272	4A	18590
HB45-BU0T-16.CDW.01	4500/600	560–2410	1600	1050	1600 x 500 x 40	210	191	428	260	1327	4A	18950
HB45-B0T-12.CDW.01	4500/600	700–2670	1600	1050	1200 x 500 x 40	210	191	333	277	1204	4A	18230
HB45-B0T-14.CDW.01	4500/600	690–2660	1600	1050	1400 x 500 x 40	210	191	385	271	1287	4A	18590
HB45-B0T-16.CDW.01	4500/600	680–2650	1600	1050	1600 x 500 x 40	210	191	429	261	1342	4A	18950
HB45-CQ0T-12.CDW.01	4500/600	560–2530	1700	1050	1200 x 500 x 40	210	191	327	275	1229	4A	18500
HB45-CQ0T-14.CDW.01	4500/600	550–2520	1700	1050	1400 x 500 x 40	210	191	379	269	1312	4A	18880
HB45-CQ0T-16.CDW.01	4500/600	540–2510	1700	1050	1600 x 500 x 40	210	191	423	259	1367	4A	19250

* Opening range measured across arm tips

Options

	RRP
	Euro
Separate sideshifter: 100 + 100 mm for ISO/FEM 4	2140
2 hydraulic functions – Independent arm control	640
Quick-release lower mountings, class 3	605
Quick-release lower mountings, class 4	810

Available on request

- Different arm dimensions
- Load backrest
- Models without sideshifter
- Manometer
- Other opening ranges

Advantages

- Fully protected valve and high-grade steel for long life
- Synchronised arm movements
- Excellent load grip
- Expertly manufactured
- High piston rods durability thanks to improved pistons joints
- Increased manoeuvrability in confined spaces
- Greater versatility

**HB-T
CDW.01**

4000 kg

Recycling clamps

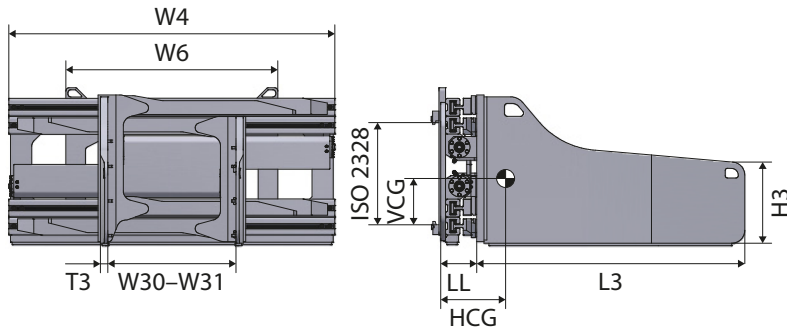

Product info

- W6 – Minimum carriage width
- With retaining and pressure relief valve
- With flow divider
- With integrated sidsifter
- Valve with regenerative circuit
- Valve with performance sidsifting control
- With frame bumper
- With gripper teeth
- With wear strips under arms
- With wear strips under frame



Model	Capacity	W30–W31*	W4	W6	Arms L3 x H3 x T3	H10	LL	HCG	VCG	Weight	ISO 2328	RRP
	kg/mm											mm
HB408-DQ0T-12.CDW.01	4000/800	580–2150	1320	1000	1200 x 500 x 45	210	211	362	260	1235	4A	20300
HB408-DQ0T-14.CDW.01	4000/800	570–2140	1320	1000	1400 x 500 x 45	210	211	367	325	1344	4A	20550
HB408-DQ0T-16.CDW.01	4000/800	560–2130	1320	1000	1600 x 500 x 45	210	211	373	384	1433	4A	21040
HB408-AQ0T-12.CDW.01	4000/800	630–2390	1450	1000	1200 x 500 x 45	210	211	355	256	1299	4A	20570
HB408-AQ0T-14.CDW.01	4000/800	620–2380	1450	1000	1400 x 500 x 45	210	211	422	257	1380	4A	20820
HB408-AQ0T-16.CDW.01	4000/800	610–2370	1450	1000	1600 x 500 x 45	210	211	486	258	1470	4A	21320
HB408-BQ0T-12.CDW.01	4000/800	590–2490	1600	1000	1200 x 500 x 45	210	211	357	265	1323	4A	21230
HB408-BQ0T-14.CDW.01	4000/800	600–2500	1600	1000	1400 x 500 x 45	210	211	418	255	1432	4A	21480
HB408-BQ0T-16.CDW.01	4000/800	610–2510	1600	1000	1600 x 500 x 45	210	211	475	265	1521	4A	21950
HB408-BQ1T-12.CDW.01	4000/800	700–2720	1600	1000	1200 x 500 x 45	210	211	353	266	1356	4A	21240
HB408-BQ1T-14.CDW.01	4000/800	710–2730	1600	1000	1400 x 500 x 45	210	211	412	261	1470	4A	21480
HB408-BQ1T-16.CDW.01	4000/800	720–2740	1600	1000	1600 x 500 x 45	210	211	468	256	1559	4A	21950

* Opening range measured across arm tips

Options

	RRP
	Euro
Separate sidsifter: 100 + 100 mm for ISO/FEM 4	2140
Hydraulic functions – Independent arm control	640
Quick-release lower mountings, class 4	810

Available on request

- Different arm dimensions
- Load backrest
- Models without sidsifter
- Manometer
- Other opening ranges
- Articulating left arm

Recycling clamps

**HB-T
CDW.01**

5000 kg

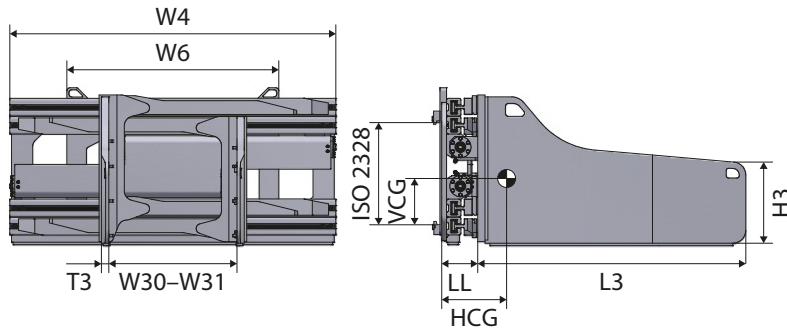

Product info

- W6 – Minimum carriage width
- With retaining and pressure relief valve
- With flow divider
- With valve block sideshifter
- Valve with regenerative circuit
- Valve with performance sideshifting control
- With frame bumper
- With gripper teeth
- With wear strips under arms
- With wear strips under frame



Model	Capacity	W30–W31*	W4	W6	Arms L3 x H3 x T3	H10	LL	HCG	VCG	Weight	ISO 2328	RRP
	kg/mm											mm
HB508-B0T-14.CDW.01	5000/800	630–2510	1600	1100	1400 x 500 x 45	210	211	390	222	1590	4A	27960
HB508-B0T-16.CDW.01	5000/800	620–2500	1600	1100	1600 x 500 x 45	210	211	419	210	1650	4A	28240
HB508-C0T-14.CDW.01	5000/800	700–2800	1800	1100	1400 x 500 x 45	210	211	380	220	1680	4A	28420
HB508-C0T-16.CDW.01	5000/800	690–2790	1800	1100	1600 x 500 x 45	210	211	409	208	1740	4A	28700

* Opening range measured across arm tips

Options

	RRP
	Euro
Separate sideshifter: 100 + 100 mm for ISO/FEM 4	2140
2 hydraulic functions – Independent arm control	640
Quick-release lower mountings, class 4	810

Available on request

- Different arm dimensions
- Class B mounting arms
- Load backrest
- Models without sideshifter
- Manometer
- Other opening ranges
- Articulating left arm

Advantages

- Fully protected valve and high-grade steel ensure a long lifespan
- Synchronised arm movements
- Excellent grip on the load
- Expertly manufactured
- High piston rods durability thanks to improved pistons joints

HBC-T

1600 kg

Pulp bale clamps

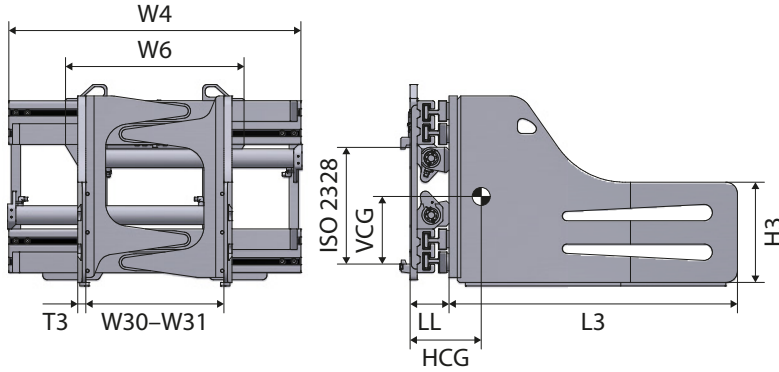

Product info

- W6 – Minimum carriage width
- With retaining and pressure relief valve
- With flow divider
- With valve block sideshifter
- With wear pads under arms



Model	Capacity	W30–W31*	W4	W6	Arms L3 x H3 x T3	H10	LL	HCG	VCG	Weight	ISO 2328	RRP
	kg/mm											mm
HBC16-AU0T-10	1600/600	470–1620	950	750	1000 x 400 x 30	180	135	249	218	420	2A	10200
HBC16-AU0T-12	1600/600	470–1620	950	750	1200 x 400 x 30	180	135	322	206	476	2A	10350
HBC16-A0T-10	1600/600	580–1840	950	750	1000 x 400 x 30	180	135	248	217	425	2A	10200
HBC16-A0T-12	1600/600	570–1830	950	750	1200 x 400 x 30	180	135	321	205	481	2A	10350
HBC16-AU1T-10	1600/600	640–1960	950	750	1000 x 400 x 30	180	135	247	216	430	2A	10200
HBC16-AU1T-12	1600/600	630–1950	950	750	1200 x 400 x 30	180	135	320	206	486	2A	10350
HBC16-AU1T-16	1600/600	620–1940	950	750	1600 x 400 x 30	180	135	390	195	550	2A	10960
HBC16-BU0T-10	1600/600	590–1960	1050	750	1000 x 400 x 30	180	135	245	216	434	2A	10560
HBC16-BU0T-12	1600/600	580–1950	1050	750	1200 x 400 x 30	180	135	319	205	490	2A	10700
HBC16-B0T-10	1600/600	670–2090	1050	750	1000 x 400 x 30	180	135	246	217	439	2A	10560
HBC16-B0T-12	1600/600	660–2080	1050	750	1200 x 400 x 30	180	135	318	204	495	2A	10700
HBC16-C0T-10	1600/600	550–1970	1150	750	1000 x 400 x 30	180	135	243	216	444	2A	10900
HBC16-C0T-12	1600/600	540–1960	1150	750	1200 x 400 x 30	180	135	313	203	500	2A	11060
HBC16-D0T-10	1600/600	590–2130	1250	820	1000 x 400 x 30	180	135	240	215	462	2A	11280
HBC16-D0T-12	1600/600	580–2120	1250	820	1200 x 400 x 30	180	135	310	202	518	2A	11410

* Opening range measured across arm tips

Options

	RRP
	Euro
Separate sideshifter: 100 + 100 mm for ISO/FEM 2	1330
Hydraulic functions – Independent arm control	640
Quick-release lower mountings, class 2	605
Frame bumpers	260
Wear strips under frame	520

Available on request

- Different arm dimensions
- Class B mounting arms
- Load backrest (see page 20)
- Models without sideshifter
- Manometer
- Other opening ranges
- Cutting Device for pulp bale steel wires (model LXA661)

Pulp bale clamps

HBC-T

2200 kg

Product info

- W6 – Minimum carriage width
- With retaining and pressure relief valve
- With flow divider
- With valve block sideshifter

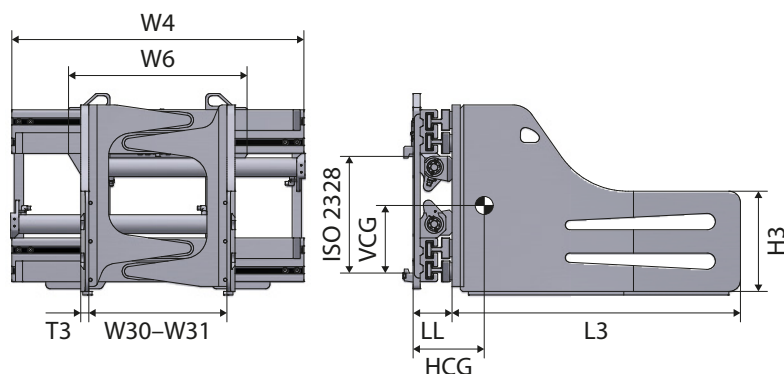

Model	Capacity	W30–W31*	W4	W6	Arms L3 x H3 x T3	H10	LL	HCG	VCG	Weight	ISO 2328	RRP
	kg/mm											mm
HBC22-AQ0T-10	2200/600	440–1660	1050	750	1000 x 400 x 30	180	137	258	235	487	2A**	11330
HBC22-AQ0T-12	2200/600	430–1650	1050	750	1200 x 400 x 30	180	137	280	204	510	2A**	11480
HBC22-A0T-10	2200/600	560–1870	1050	750	1000 x 400 x 30	180	137	259	234	492	2A**	11330
HBC22-A0T-12	2200/600	550–1860	1050	750	1200 x 400 x 30	180	137	279	205	515	2A**	11480
HBC22-B0T-10	2200/600	670–2210	1150	750	1000 x 400 x 30	180	137	253	234	506	2A**	11740
HBC22-B0T-12	2200/600	660–2200	1150	750	1200 x 400 x 30	180	137	278	204	531	2A**	11870
HBC22-BU0T-10	2200/600	490–1860	1150	750	1000 x 400 x 30	180	137	254	233	496	2A**	11740
HBC22-BU0T-12	2200/600	480–1850	1150	750	1200 x 400 x 30	180	137	278	203	521	2A**	11870
HBC22-BQ0T-10	2200/600	580–2030	1150	750	1000 x 400 x 30	180	137	255	235	501	2A**	11740
HBC22-BQ0T-12	2200/600	570–2020	1150	750	1200 x 400 x 30	180	137	279	204	526	2A**	11870
HBC22-CQ0T-10	2200/600	480–1930	1250	820	1000 x 400 x 30	180	137	248	234	514	2A**	11990
HBC22-CQ0T-12	2200/600	470–1920	1250	820	1200 x 400 x 30	180	137	275	204	539	2A**	12130
HBC22-CU0T-10	2200/600	570–2110	1250	820	1000 x 400 x 30	180	137	249	233	519	2A**	11990
HBC22-CU0T-12	2200/600	560–2100	1250	820	1200 x 400 x 30	180	137	274	203	544	2A**	12130
HBC22-CQ1T-10	2200/600	660–2300	1250	820	1000 x 400 x 30	180	137	247	233	524	2A**	11990
HBC22-CQ1T-12	2200/600	650–2290	1250	820	1200 x 400 x 30	180	137	274	205	549	2A**	12130
HBC22-DU0T-10	2200/600	550–2130	1320	820	1000 x 400 x 30	180	137	240	233	522	2A**	12050
HBC22-DU0T-12	2200/600	540–2120	1320	820	1200 x 400 x 30	180	137	270	203	561	2A**	12180
HBC22-D0T-10	2200/600	670–2320	1320	820	1000 x 400 x 30	180	137	239	232	527	2A**	12050
HBC22-D0T-12	2200/600	660–2310	1320	820	1200 x 400 x 30	180	137	269	202	566	2A**	12180
HBC22-E0T-10	2200/600	640–2470	1450	820	1000 x 400 x 30	180	137	238	231	537	2A**	12690
HBC22-E0T-12	2200/600	630–2460	1450	820	1200 x 400 x 30	180	137	265	201	577	2A**	12810
HBC22-EU0T-10	2200/600	610–2380	1450	820	1000 x 400 x 30	180	137	237	230	532	2A**	12690
HBC22-EU0T-12	2200/600	600–2370	1450	820	1200 x 400 x 30	180	137	264	200	572	2A**	12810
HBC22-EQ0T-10	2200/600	700–2570	1450	820	1000 x 400 x 30	180	137	239	232	542	2A**	12690
HBC22-EQ0T-12	2200/600	690–2560	1450	820	1200 x 400 x 30	180	137	266	202	582	2A**	12810

* Opening range measured across arm tips

** Available on request mounting class 3A

HBC-T**2600 kg
3000 kg**

Pulp bale clamps

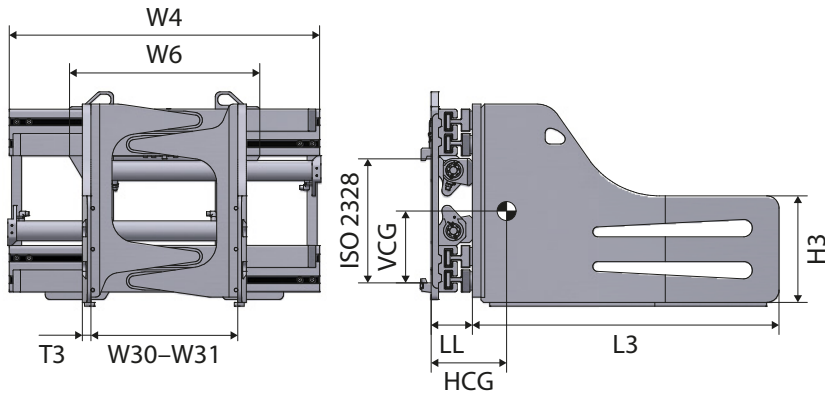

Product info

- W6 – Minimum carriage width
- With retaining and pressure relief valve
- With flow divider
- With valve block sideshifter
- With wear strips
- Valve with regenerative circuit
- Valve with performance sideshifting control



Model	Capacity	W30–W31*	W4	W6	Arms L3 x H3 x T3	H10	LL	HCG	VCG	Weight	ISO 2328	RRP
	kg/mm											mm
HBC26-AU0T-10	2600/600	490–1840	1150	870	1000 x 400 x 35	170	163	275	268	782	3A	12760
HBC26-AU0T-12	2600/600	490–1840	1150	870	1200 x 400 x 35	170	163	334	241	825	3A	13070
HBC26-A0T-10	2600/600	620–2090	1150	870	1000 x 400 x 35	170	163	276	267	792	3A	12760
HBC26-A0T-12	2600/600	610–2080	1150	870	1200 x 400 x 35	170	163	335	242	835	3A	13070
HBC26-AQ0T-10	2600/600	550–1930	1150	870	1000 x 400 x 35	170	163	274	268	787	3A	12760
HBC26-AQ0T-12	2600/600	540–1920	1150	870	1200 x 400 x 35	170	163	333	242	830	3A	13070
HBC26-B0T-10	2600/600	520–1990	1250	870	1000 x 400 x 35	170	163	270	268	796	3A	13280
HBC26-B0T-12	2600/600	510–1980	1250	870	1200 x 400 x 35	170	163	323	243	839	3A	13600
HBC26-CQ0T-10	2600/600	550–2130	1320	870	1000 x 400 x 35	170	163	270	269	809	3A	13550
HBC26-CQ0T-12	2600/600	550–2130	1320	870	1200 x 400 x 35	170	163	314	242	851	3A	13850
HBC26-C0T-10	2600/600	640–2300	1320	870	1000 x 400 x 35	170	163	269	268	814	3A	13550
HBC26-C0T-12	2600/600	630–2290	1320	870	1200 x 400 x 35	170	163	315	243	854	3A	13850
HBC26-DQ0T-12	2600/600	420–2000	1450	870	1200 x 400 x 35	170	163	313	243	871	3A	14490
HBC26-D0T-10	2600/600	560–2290	1450	920	1000 x 400 x 35	170	165	268	268	846	3A	14180
HBC26-D0T-12	2600/600	560–2290	1450	920	1200 x 400 x 35	170	165	314	242	874	3A	14490
HBC26-DU0T-10	2600/600	620–2390	1450	870	1000 x 400 x 35	170	163	270	269	849	3A	14180
HBC26-DU0T-12	2600/600	610–2380	1450	870	1200 x 400 x 35	170	163	312	242	879	3A	14490
HBC30-AQ0T-10	3000/600	540–1930	1150	870	1000 x 450 x 35	170	163	275	267	797	3A	13070
HBC30-AQ0T-12	3000/600	530–1920	1150	870	1200 x 450 x 35	170	163	334	241	840	3A	13380
HBC30-BQ0T-10	3000/600	560–2140	1320	870	1000 x 450 x 35	170	163	271	270	819	3A	13720
HBC30-BQ0T-12	3000/600	550–2130	1320	870	1200 x 450 x 35	170	163	315	242	861	3A	14000
HBC30-CQ0T-12	3000/600	570–2300	1450	920	1200 x 450 x 35	170	163	316	243	881	3A	15180

* Opening range measured across arm tips

Pulp bale clamps

HBC-T

3500 kg

Product info

- W6 – Minimum carriage width
- With retaining and pressure relief valve
- With flow divider
- With valve block sideshifter
- With wear strips
- Valve with regenerative circuit
- Valve with performance sideshifting control

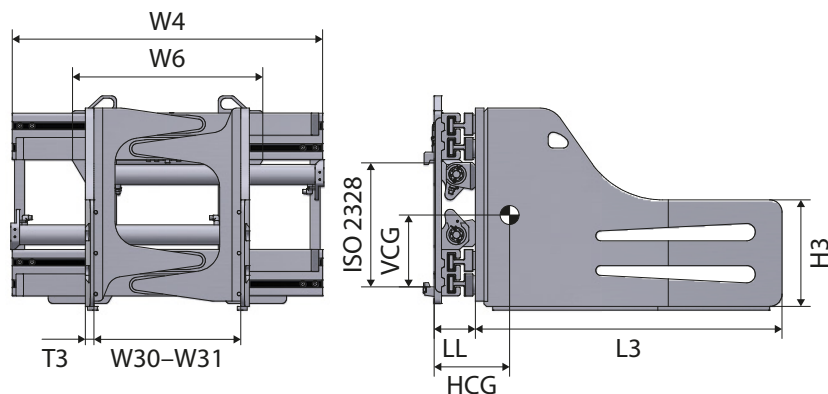

Model	Capacity	W30–W31*	W4	W6	Arms L3 x H3 x T3	H10	LL	HCG	VCG	Weight	ISO 2328	RRP
	kg/mm											mm
HBC35-AQ0T-10	3500/600	580–1980	1150	870	1000 x 450 x 40	165	172	275	262	918	3A**	13440
HBC35-AQ0T-12	3500/600	570–1970	1150	870	1200 x 450 x 40	165	172	298	245	960	3A**	13710
HBC35-BU0T-10	3500/600	610–2140	1250	870	1000 x 450 x 40	165	172	274	262	971	3A**	13660
HBC35-BU0T-12	3500/600	600–2130	1250	870	1200 x 450 x 40	165	172	297	246	1013	3A**	13940
HBC35-CQ0T-12	3500/600	490–2110	1450	920	1200 x 450 x 40	165	177	296	247	1073	3A**	15910
HBC35-CQ0T-14	3500/600	480–2100	1450	920	1400 x 450 x 40	165	177	350	239	1124	3A**	16170
HBC35-CQ0T-16	3500/600	460–2080	1450	920	1600 x 450 x 40	165	177	386	235	1156	3A**	16430
HBC35-CQ1T-10	3500/600	640–2400	1450	920	1000 x 450 x 40	165	177	273	261	1031	3A**	15630
HBC35-CQ1T-12	3500/600	630–2390	1450	920	1200 x 450 x 40	165	177	295	248	1083	3A**	15910
HBC35-CQ1T-16	3500/600	610–2370	1450	920	1600 x 450 x 40	165	177	386	234	1166	3A**	16430
HBC35-DU0T-10	3500/600	710–2680	1600	920	1000 x 450 x 40	165	177	272	260	1082	3A**	15970
HBC35-DU0T-12	3500/600	700–2670	1600	920	1200 x 450 x 40	165	177	290	249	1136	3A**	16250
HBC35-DU0T-16	3500/600	680–2650	1600	920	1600 x 450 x 40	165	177	386	234	1216	3A**	16770
HBC35-EQ0T-16	3500/600	570–2520	1700	920	1600 x 450 x 40	165	177	385	232	1310	3A**	17000

* Opening range measured across arm tips

** Available on request mounting class 4A

Options

	RRP
	Euro
Separate sideshifter: 100 + 100 mm for ISO/FEM 3	1800
2 hydraulic functions – Independent arm control	640
Quick-release lower mountings, class 3	605
Frame bumper	260
Wear strips under frame	520
Wear strips under arms	395
Gripper teeth	260

Available on request

- Different arm dimensions
- Class B mounting arms
- Load backrest
- Models without sideshifter
- Manometer
- Other opening ranges
- Cutting Device for pulp bale steel wires (model LXA661)

See this attachment in action



HBC-T

4200 kg

Pulp bale clamps

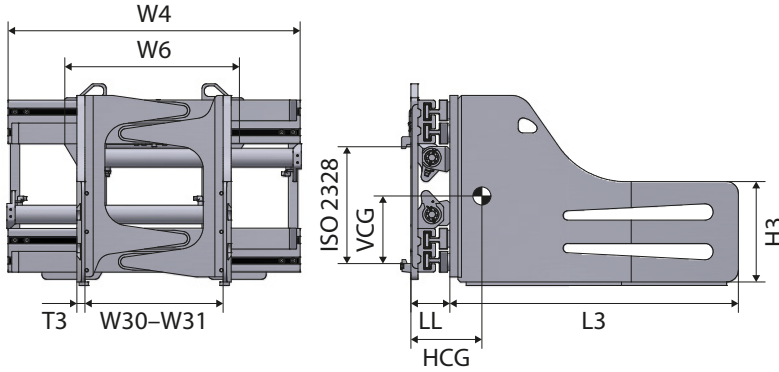

Product info

- W6 – Minimum carriage width
- With retaining and pressure relief valve
- With flow divider
- With valve block sideshifter
- With wear strips under arms
- Valve with regenerative circuit
- Valve with performance sideshifting control



Model	Capacity	W30–W31*	W4	W6	Arms L3 x H3 x T3	H10	LL	HCG	VCG	Weight	ISO 2328	RRP
	kg/mm											mm
HBC42-CU0T-10	4200/600	480–1950	1320	950	1000 x 500 x 40	210	183	250	299	946	3A	19260
HBC42-CU0T-12	4200/600	470–1940	1320	950	1200 x 500 x 40	210	183	306	288	956	3A	19530
HBC42-CU1T-10	4200/600	590–2150	1320	950	1200 x 500 x 40	210	183	251	300	913	3A	19260
HBC42-CU1T-12	4200/600	580–2130	1320	950	1200 x 500 x 40	210	183	305	288	966	3A	19530
HBC42-DQ0T-12	4200/600	480–2100	1450	1050	1200 x 500 x 40	210	183	301	289	1013	3A	19800
HBC42-DQ0T-14	4200/600	470–2090	1450	1050	1400 x 500 x 40	210	183	352	280	1083	3A	20200
HBC42-DQ0T-16	4200/600	460–2080	1450	1050	1600 x 500 x 40	210	183	401	271	1153	3A	20600
HBC42-DQ1T-16	4200/600	580–2300	1450	1050	1600 x 500 x 40	210	183	400	270	1173	3A	20600
HBC42-EU0T-10	4200/600	590–2440	1600	1050	1000 x 500 x 40	210	183	247	298	988	3A	19930
HBC42-EU0T-12	4200/600	580–2430	1600	1050	1200 x 500 x 40	210	183	297	290	1058	3A	20200
HBC42-EU0T-14	4200/600	570–2420	1600	1050	1400 x 500 x 40	210	183	348	281	1128	3A	20600
HBC42-EU0T-16	4200/600	560–2410	1600	1050	1600 x 500 x 40	210	183	397	272	1198	3A	21000
HBC42-EU1T-10	4200/600	710–2680	1600	1050	1000 x 500 x 40	210	183	245	297	1008	3A	19930
HBC42-EU1T-12	4200/600	700–2670	1600	1050	1200 x 500 x 40	210	183	295	289	1078	3A	20200
HBC42-EU1T-14	4200/600	690–2660	1600	1050	1400 x 500 x 40	210	183	346	280	1148	3A	20600
HBC42-EU1T-16	4200/600	680–2650	1600	1050	1600 x 500 x 40	210	183	395	271	1218	3A	21000
HBC42-FQ0T-12	4200/600	570–2520	1700	1050	1200 x 500 x 40	210	183	399	270	1263	3A	20500

* Opening range measured across arm tips

Pulp bale clamps

HBC-T

4200 kg

Product info

- W6 – Minimum carriage width
- With retaining and pressure relief valve
- With flow divider
- With valve block sideshifter
- With wear strips under arms
- Valve with regenerative circuit
- Valve with performance sideshifting control

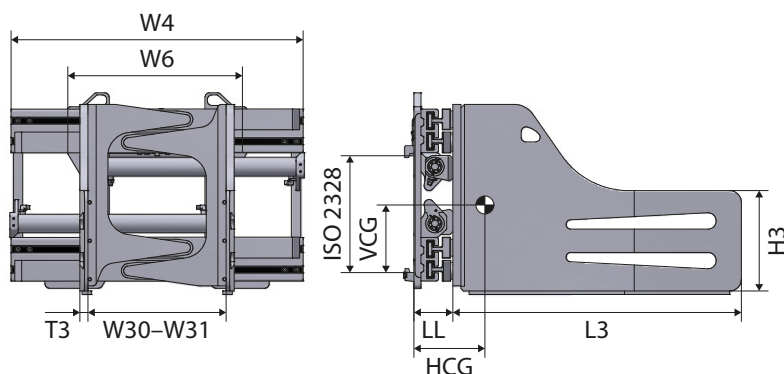

Model	Capacity	W30–W31*	W4	W6	Arms L3 x H3 x T3	H10	LL	HCG	VCG	Weight	ISO 2328	RRP
	kg/mm											mm
HBC42-CU04T-10	4200/600	480–1950	1320	950	1000 x 500 x 40	210	193	255	297	978	4A	19430
HBC42-CU04T-12	4200/600	470–1940	1320	950	1200 x 500 x 40	210	193	311	286	988	4A	19710
HBC42-CU14T-10	4200/600	590–2150	1320	950	1200 x 500 x 40	210	193	256	298	945	4A	19430
HBC42-CU14T-12	4200/600	580–2130	1320	950	1200 x 500 x 40	210	193	310	286	998	4A	19710
HBC42-DQ04T-12	4200/600	480–2100	1450	1050	1200 x 500 x 40	210	193	306	287	1045	4A	19980
HBC42-DQ04T-14	4200/600	470–2090	1450	1050	1400 x 500 x 40	210	193	357	278	1115	4A	20380
HBC42-DQ04T-16	4200/600	460–2080	1450	1050	1600 x 500 x 40	210	193	406	269	1185	4A	20770
HBC42-DQ14T-16	4200/600	580–2300	1450	1050	1600 x 500 x 40	210	193	405	268	1205	4A	20770
HBC42-EU04T-10	4200/600	590–2440	1600	1050	1000 x 500 x 40	210	193	252	296	1020	4A	20100
HBC42-EU04T-12	4200/600	580–2430	1600	1050	1200 x 500 x 40	210	193	302	288	1090	4A	20380
HBC42-EU04T-14	4200/600	570–2420	1600	1050	1400 x 500 x 40	210	193	353	279	1160	4A	20770
HBC42-EU04T-16	4200/600	560–2410	1600	1050	1600 x 500 x 40	210	193	402	270	1230	4A	21170
HBC42-EU14T-10	4200/600	710–2680	1600	1050	1000 x 500 x 40	210	193	250	295	1040	4A	20100
HBC42-EU14T-12	4200/600	700–2670	1600	1050	1200 x 500 x 40	210	193	300	287	1110	4A	20380
HBC42-EU14T-14	4200/600	690–2660	1600	1050	1400 x 500 x 40	210	193	351	278	1180	4A	20770
HBC42-EU04T-16	4200/600	680–2650	1600	1050	1600 x 500 x 40	210	193	400	269	1250	4A	21170
HBC42-FQ04T-12	4200/600	570–2520	1700	1050	1200 x 500 x 40	210	193	404	268	1295	4A	20670

* Opening range measured across arm tips

Options

	RRP
	Euro
Separate sideshifter: 100 + 100 mm for ISO/FEM 4	2140
2 hydraulic functions – Independent arm control	640
Quick-release lower mountings, class 4	810
Frame bumper	260
Wear strips under frame	520
Wear strips under arms	395
Gripper teeth	260

Available on request

- Different arm dimensions
- Class B mounting arms
- Load backrest
- Models without sideshifter
- Manometer
- Other opening ranges
- Cutting Device for pulp bale steel wires (model LXA661)

HBC-T

4000 kg
5000 kg

Pulp bale clamps

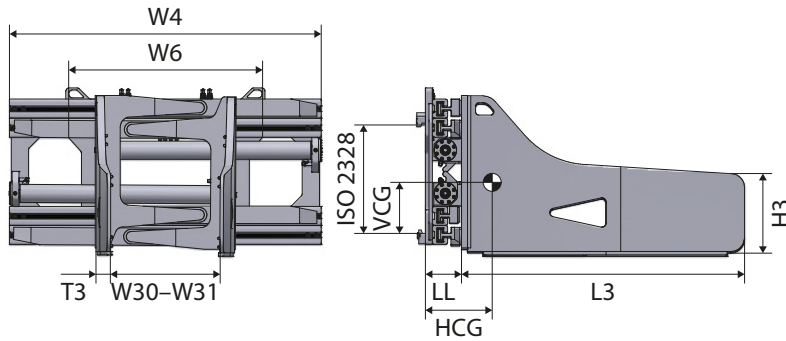

Product info

- W6 – Minimum carriage width
- With retaining and pressure relief valve
- With flow divider
- With valve block sideshifter
- With wear strips under arms
- Valve with regenerative circuit
- Valve with performance sideshifting control



Model	Capacity	W30–W31*	W4	W6	Arms L3 x H3 x T3	H10	LL	HCG	VCG	Weight	ISO 2328	RRP
	kg/mm											mm
HBC408-BQ0T-12	4000/800	570–2140	1320	1000	1200 x 500 x 50	180	210	347	282	1152	4A	23620
HBC408-BQ0T-14	4000/800	560–2130	1320	1000	1400 x 500 x 50	180	210	405	272	1230	4A	23890
HBC408-BQ0T-16	4000/800	550–2120	1320	1000	1600 x 500 x 50	180	210	460	262	1310	4A	24170
HBC408-CQ0T-12	4000/800	600–2320	1450	1000	1200 x 500 x 50	180	210	343	280	1182	4A	23850
HBC408-CQ0T-14	4000/800	590–2310	1450	1000	1400 x 500 x 50	180	210	401	270	1260	4A	24120
HBC408-CQ0T-16	4000/800	580–2300	1450	1000	1600 x 500 x 50	180	210	454	264	1340	4A	24400
HBC408-AQ0T-12	4000/800	630–2530	1600	1000	1200 x 500 x 50	180	210	339	281	1199	4A	24080
HBC408-AQ0T-14	4000/800	620–2520	1600	1000	1400 x 500 x 50	180	210	397	268	1290	4A	24350
HBC408-AQ0T-16	4000/800	610–2510	1600	1000	1600 x 500 x 50	180	210	450	266	1340	4A	24620
HBC408-AQ1T-12	4000/800	740–2760	1600	1000	1200 x 500 x 50	180	210	338	280	1178	4A	24080
HBC408-AQ1T-14	4000/800	730–2750	1600	1000	1400 x 500 x 50	180	210	396	267	1300	4A	24350
HBC408-AQ1T-16	4000/800	720–2740	1600	1000	1600 x 500 x 50	180	210	446	265	1380	4A	24620
HBC508-AQ0T-12	5000/800	580–2380	1600	1100	1200 x 500 x 50	145	238	301	315	1440	4A	29780
HBC508-AQ0T-14	5000/800	570–2370	1600	1100	1400 x 500 x 50	145	238	345	308	1488	4A	30050
HBC508-AQ0T-16	5000/800	560–2360	1600	1100	1600 x 500 x 50	145	238	389	299	1546	4A	30320
HBC508-AU0T-12	5000/800	680–2580	1600	1100	1200 x 500 x 50	145	238	300	313	1450	4A	29780
HBC508-AU0T-14	5000/800	670–2570	1600	1100	1400 x 500 x 50	145	238	344	307	1498	4A	30050
HBC508-AU0T-16	5000/800	660–2560	1600	1100	1600 x 500 x 50	145	238	388	298	1556	4A	30320
HBC508-BQ0T-12	5000/800	630–2580	1700	1100	1200 x 500 x 50	145	238	297	312	1476	4A	30670
HBC508-BQ0T-14	5000/800	620–2570	1700	1100	1400 x 500 x 50	145	238	341	306	1524	4A	30640
HBC508-BQ0T-16	5000/800	610–2560	1700	1100	1600 x 500 x 50	145	238	385	299	1572	4A	30620
HBC508-CQ0T-12	5000/800	650–2720	1800	1100	1200 x 500 x 50	145	238	294	311	1502	4A	30960
HBC508-CQ0T-14	5000/800	640–2710	1800	1100	1400 x 500 x 50	145	238	338	305	1550	4A	30920
HBC508-CQ0T-16	5000/800	630–2700	1800	1100	1600 x 500 x 50	145	238	382	299	1598	4A	31210
HBC508-DQ0T-16	5000/800	680–3100	2100	1400	1600 x 500 x 50	145	238	363	301	1685	4A	32240

* Opening range measured across arm tips

Pulp bale clamps

HBC-T

6500 kg
8000 kg

Product info

- W6 – Minimum carriage width
- With retaining and pressure relief valve
- With flow divider
- With valve block sideshifter
- With wear strips under arms
- Valve with regenerative circuit
- Valve with performance sideshifting control

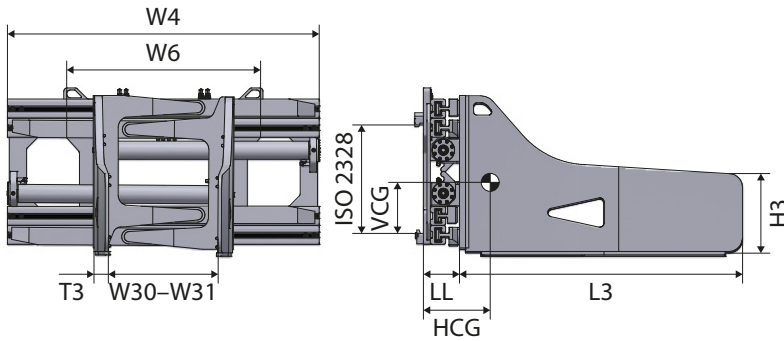

Model	Capacity	W30–W31*	W4	W6	Arms L3 x H3 x T3	H10	LL	HCG	VCG	Weight	ISO 2328	RRP
	kg/mm											mm
HBC658-COT-14	6500/800	700–3190	2200	1250	1600 x 600 x 70	210	238	331	307	1945	4A	34890
HBC658-COT-16	6500/800	690–3180	2200	1250	1600 x 600 x 70	210	238	361	305	1995	4A	37450
HBC808-AOT-16	8000/800	650–2800	2000	1150	1600 x 550 x 90	210	254	345	396	2480	4A	On request

* Opening range measured across arm tips

Options

	RRP
	Euro
Separate sideshifter: 100 + 100 mm for ISO/FEM 4	2140
2 hydraulic functions – Independent arm control	640
Quick-release lower mountings, class 4	810
Frame bumper	260
Wear strips under frame	520
Wear strips under arms	395
Gripper teeth	260

Available on request

- Different arm dimensions
- Class B mounting arms
- Load backrest
- Models without sideshifter
- Manometer
- Other opening ranges
- Articulating left arm for HBC408 and HBC508
- Cutting Device for pulp bale steel wires (model LXA661)

Advantages

- Fully protected valve and high-grade steel ensure a long lifespan
- Synchronised arm movements
- Excellent grip on the load
- Expertly manufactured
- High piston rods durability thanks to improved pistons joints
- Increased manoeuvrability in tight spaces
- More versatility
- Different dimensions

HBR

1000 kg
2200 kg

Rotating bale clamp 360°

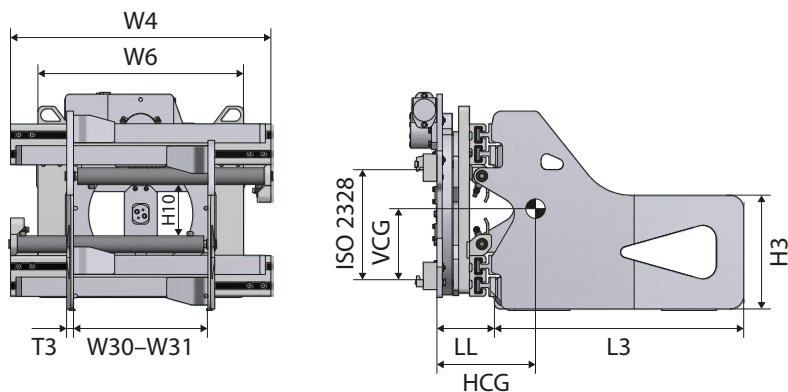

Product info

- Clamps are also suitable for handling pulp bales
- W6 – Minimum carriage width



Model	Capacity	W30–W31*	W4	W6	Arms L3 x H3 x T3	H10	LL	HCG	VCG	Weight	ISO 2328	RRP
	kg/mm											mm
HBR10-A0-09	1000/500	445–1585	950	750	900 x 400 x 25	195	264	252	247	576	2A	14270
HBR10-A0-10	1000/500	440–1580	950	750	1000 x 400 x 25	195	264	283	241	593	2A	14540
HBR10-A1-09	1000/500	555–1795	950	750	900 x 400 x 25	195	264	250	247	582	2A	14270
HBR10-A1-10	1000/500	550–1790	950	750	1000 x 400 x 25	195	264	279	243	600	2A	14540
HBR14-A0-09	1400/500	555–1790	950	750	900 x 400 x 25	195	264	254	247	583	2A	14790
HBR14-A0-10	1400/500	550–1790	950	750	1000 x 400 x 25	195	264	285	241	601	2A	15080
HBR14-B0-09	1400/500	455–1695	1050	750	900 x 400 x 25	195	264	251	248	589	2A	15020
HBR14-B0-10	1400/500	450–1690	1050	750	1000 x 400 x 25	195	264	278	242	607	2A	15260
HBR14-C0-09	1400/500	455–1795	1150	750	900 x 400 x 25	195	264	243	248	596	2A	15360
HBR14-C0-10	1400/500	450–1790	1150	750	1000 x 400 x 25	195	264	270	242	613	2A	15590
HBR14-C1-09	1400/500	655–2195	1150	750	900 x 400 x 25	195	264	241	249	611	2A	15360
HBR14-C1-10	1400/500	650–2190	1150	750	1000 x 400 x 25	195	264	268	243	629	2A	15590
HBR18-A0-10	1800/500	550–1770	950	750	1000 x 400 x 30	185	264	286	240	630	2A	15450
HBR18-A0-12	1800/500	540–1760	950	750	1200 x 400 x 30	185	264	351	258	695	2A	15640
HBR18-B0-10	1800/500	450–1670	1050	750	1000 x 400 x 30	185	264	279	265	645	2A	15820
HBR18-B0-12	1800/500	440–1660	1050	750	1200 x 400 x 30	185	264	326	258	682	2A	15960
HBR18-C0-10	1800/500	560–1980	1150	750	1000 x 400 x 30	185	264	275	265	660	2A	16170
HBR18-C0-12	1800/500	550–1970	1150	750	1200 x 400 x 30	185	264	323	258	701	2A	16330
HBR18-D0-10	1800/500	450–1870	1250	750	1000 x 400 x 30	185	264	268	265	659	2A	16520
HBR18-D0-12	1800/500	440–1860	1250	750	1200 x 400 x 30	185	264	318	258	705	2A	16670
HBR22-A0-10	2200/500	580–1840	950	750	1000 x 400 x 30	180	271	283	239	635	2A	15950
HBR22-A0-12	2200/500	570–1830	950	750	1200 x 400 x 30	180	271	348	257	700	2A	16117
HBR22-B0-10	2200/500	670–2090	1050	750	1000 x 400 x 30	180	271	276	264	650	2A	16310
HBR22-B0-12	2200/500	660–2080	1050	750	1200 x 400 x 30	180	271	323	257	687	2A	16490
HBR22-C0-10	2200/500	550–1970	1150	750	1000 x 400 x 30	180	271	272	264	665	2A	16700
HBR22-C0-12	2200/500	540–1960	1150	750	1200 x 400 x 30	180	271	320	257	706	2A	16860
HBR22-D0-10	2200/500	590–2130	1250	750	1000 x 400 x 30	180	271	265	264	664	2A	17100
HBR22-D0-12	2200/500	580–2120	1250	750	1200 x 400 x 30	180	271	315	257	710	2A	17220

* Opening range measured across arm tips

Rotating bale clamp 360°

HBR

2600 kg
3500 kg

Product info

- 360° rotation
- Continuous rotation in both directions
- Fast rotation and high torque
- Block valve with flow divider for excellent arms synchronization
- Excellent visibility through the frame
- W6 – Minimum carriage width

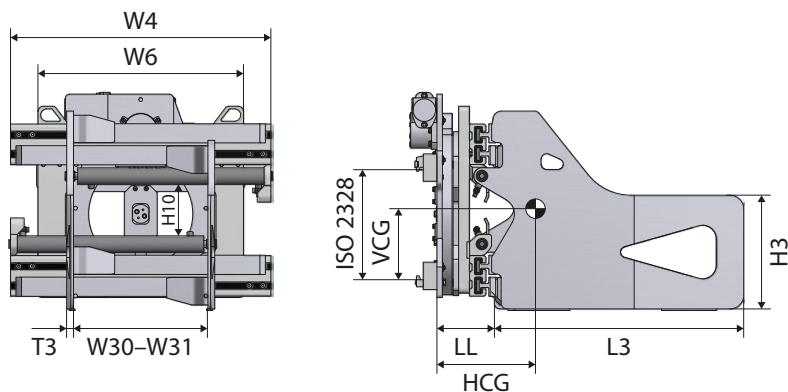

Model	Capacity	W30–W31*	W4	W6	Arms L3 x H3 x T3	H10	LL	HCG	VCG	Weight	ISO 2328	RRP
	kg/mm											mm
HBR26-A03-10	2600/500	560–1870	1050	900	1000 x 400 x 35	180	273	283	272	691	3A	18120
HBR26-A03-12	2600/500	520–1840	1050	900	1200 x 400 x 35	180	273	323	263	742	3A	18260
HBR26-B03-10	2600/500	680–2210	1150	900	1000 x 400 x 35	180	273	280	271	701	3A	18550
HBR26-B03-12	2600/500	670–2200	1150	900	1200 x 400 x 35	180	273	320	262	750	3A	18670
HBR26-C03-10	2600/500	540–2030	1250	900	1000 x 400 x 35	180	273	276	270	711	3A	18950
HBR26-C03-12	2600/500	530–2020	1250	900	1200 x 400 x 35	180	273	318	261	758	3A	19070
HBR26-D03-10	2600/500	680–2330	1320	900	1000 x 400 x 35	180	273	273	269	720	3A	19430
HBR26-D03-12	2600/500	670–2320	1320	900	1200 x 400 x 35	180	273	316	260	764	3A	19630
HBR30-A0-12	3000/500	620–2090	1150	900	1200 x 400 x 35	175	290	294	357	1132	3A	21240
HBR30-A0-14	3000/500	610–2080	1150	900	1400 x 400 x 35	175	290	353	332	1175	3A	21510
HBR30-B0-12	3000/500	520–1980	1250	900	1200 x 400 x 35	175	290	288	358	1136	3A	21560
HBR30-B0-14	3000/500	510–1980	1250	900	1400 x 400 x 35	175	290	400	288	1078	3A	21950
HBR30-C0-12	3000/500	640–2300	1320	900	1200 x 400 x 35	175	290	287	358	1154	3A	21790
HBR30-C0-14	3000/500	630–2290	1320	900	1400 x 400 x 35	175	290	395	288	1116	3A	22170
HBR35-A0-12	3500/500	440–1740	1150	1050	1200 x 400 x 35	170	295	294	357	1092	3A	20980
HBR35-A0-14	3500/500	430–1730	1150	1050	1400 x 400 x 35	170	295	353	332	1135	3A	21350
HBR35-B0-12	3500/500	700–2430	1320	1050	1200 x 400 x 35	170	295	290	356	1165	3A	21580
HBR35-B0-14	3500/500	690–2420	1320	1050	1400 x 400 x 35	170	295	349	331	1205	3A	21950
HBR35-C0-12	3500/500	570–2300	1450	1050	1200 x 400 x 35	170	295	284	355	1172	3A	21870
HBR35-C0-14	3500/500	560–2290	1450	1050	1400 x 400 x 35	170	295	349	330	1213	3A	22230

* Opening range measured across arm tips

HBR**4200 kg**

Rotating bale clamp 360°

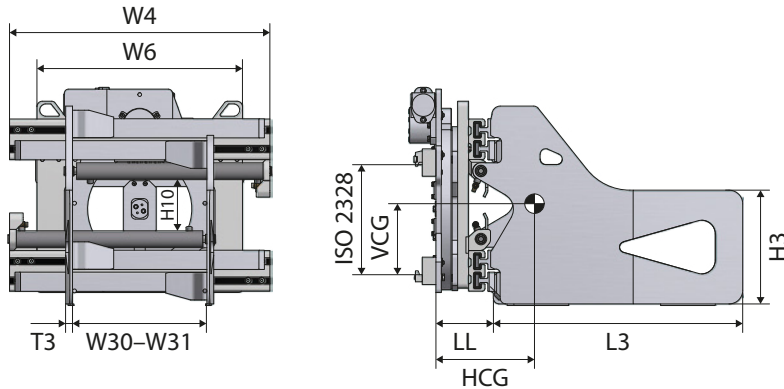

Product info

- 360° rotation
- Continuous rotation in both directions
- Fast rotation and high torque
- Block valve with flow divider for excellent arms synchronization
- Excellent visibility through the frame
- W6 – Minimum carriage width



Model	Capacity	W30–W31*	W4	W6	Arms L3 x H3 x T3	H10	LL	HCG	VCG	Weight	ISO 2328	RRP
	kg/mm											mm
HBR42-A0-12	4200/500	630–2070	1150	1050	1200 x 450 x 40	165	304	363	318	1256	3A	23420
HBR42-A0-14	4200/500	620–2060	1150	1050	1400 x 450 x 40	165	304	410	311	1303	3A	23720
HBR42-A0-16	4200/500	610–2050	1150	1050	1600 x 450 x 40	165	304	457	305	1351	3A	24030
HBR42-B0-12	4200/500	590–2160	1320	1050	1200 x 450 x 40	165	304	344	322	1296	3A	23640
HBR42-B0-14	4200/500	580–2150	1320	1050	1400 x 450 x 40	165	304	391	315	1370	3A	23940
HBR42-B0-16	4200/500	570–2140	1320	1050	1600 x 450 x 40	165	304	441	308	1403	3A	24260
HBR42-C0-12	4200/500	690–2510	1450	1050	1200 x 450 x 40	165	304	336	324	1359	3A	23940
HBR42-C0-14	4200/500	680–2500	1450	1050	1400 x 450 x 40	165	304	389	314	1410	3A	24270
HBR42-C0-16	4200/500	670–2490	1450	1050	1600 x 450 x 40	165	304	425	311	1442	3A	25310

* Opening range measured across arm tips

Options

	RRP
	Euro
Separate sidershifter: 100 + 100 mm for ISO/FEM 2	1330
Separate sidershifter: 100 + 100 mm for ISO/FEM 3	1800
2 hydraulic functions – Independent arm control	965
Quick-release lower mountings, class 2 or class 3	605
Gripper teeth	260
Wear strips under arms	395
Frame bumper	260

Available on request

- Different arm dimensions
- Class B mounting arms
- Waste paper box arm models
- Other opening ranges

Advantages

- Fully protected valve and high-grade steel for long life
- Synchronised arm movements
- Excellent load grip
- Expertly manufactured
- High piston rods durability thanks to improved pistons joints
- Makes dumping loads more efficient

Multi-purpose clamp with rubber-faced arms

HBG-T

1000 kg
2300 kg

Product info

- Block valve with flow divider for excellent arms synchronization
- Pressure-regulating valve
- Excellent visibility through the frame
- Bolted rubbered plates for avoide load damage
- W6 – Minimum carriage width
- With valve block sideshifter

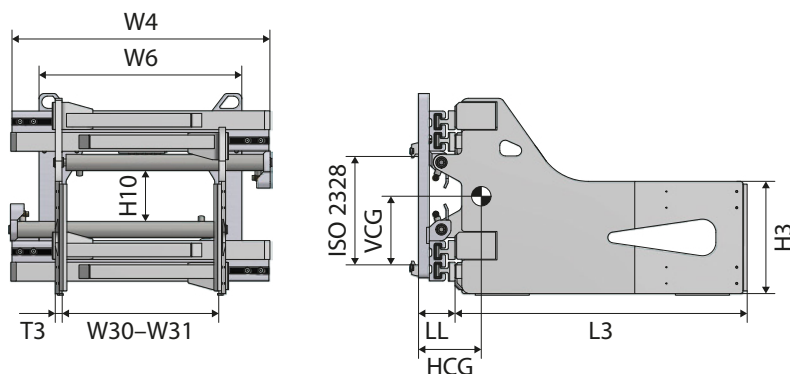

Model	Capacity	W30–W31*	W4	W6	Arms L3 x H3 x T3	H10	LL	HCG	VCG	Weight	ISO 2328	RRP
	kg/mm											mm
HBG10-A0T-09	1000/500	415–1555	950	750	900 x 400 x 41	190	150	255	218	393	2A	8600
HBG10-A0T-10	1000/500	410–1550	950	750	1000 x 400 x 41	190	150	280	215	407	2A	8770
HBG10-A1T-09	1000/500	525–1765	950	750	900 x 400 x 41	190	150	254	218	395	2A	8600
HBG10-A1T-10	1000/500	510–1750	950	750	1000 x 400 x 41	190	150	280	214	409	2A	8770
HBG14-A0T-09	1400/500	515–1755	950	750	900 x 400 x 41	195	150	240	225	368	2A	8890
HBG14-A0T-10	1400/500	510–1750	950	750	1000 x 400 x 41	195	150	242	218	379	2A	9200
HBG14-B0T-09	1400/500	415–1655	1050	750	900 x 400 x 41	195	150	234	218	380	2A	9300
HBG14-B0T-10	1400/500	410–1650	1050	750	1000 x 400 x 41	195	150	240	218	398	2A	9540
HBG14-C0T-09	1400/500	415–1755	1150	750	900 x 400 x 41	195	150	241	218	405	2A	9650
HBG14-C0T-10	1400/500	410–1750	1150	750	1000 x 400 x 41	195	150	241	218	410	2A	9910
HBG14-C1T-09	1400/500	615–2155	1150	750	900 x 400 x 41	195	150	241	218	413	2A	9650
HBG14-C1T-10	1400/500	610–2150	1150	750	1000 x 400 x 41	195	150	241	218	418	2A	9910
HBG18-A0T-10	1900/500	530–1750	950	750	1000 x 400 x 46	185	165	279	211	436	2A	9680
HBG18-A0T-12	1900/500	520–1740	950	750	1200 x 400 x 46	185	165	281	211	475	2A	9820
HBG18-B0T-10	1900/500	410–1640	1050	750	1000 x 400 x 46	185	165	357	201	455	2A	10010
HBG18-B0T-12	1900/500	400–1630	1050	750	1200 x 400 x 46	185	165	360	201	493	2A	10200
HBG18-C0T-10	1900/500	530–1950	1150	750	1000 x 400 x 46	185	165	348	203	457	2A	10410
HBG18-C0T-12	1900/500	520–1940	1150	750	1200 x 400 x 46	185	165	350	203	513	2A	10590
HBG18-D0T-10	1900/500	430–1850	1250	750	1000 x 400 x 46	185	165	337	205	475	2A	10800
HBG18-D0T-12	1900/500	420–1840	1250	750	1200 x 400 x 46	185	165	339	205	515	2A	10950
HBG22-A0T-10	2300/500	540–1770	950	750	1000 x 400 x 46	180	165	279	211	436	2A	10220
HBG22-A0T-12	2300/500	530–1760	950	750	1200 x 400 x 46	180	165	281	211	475	2A	10400
HBG22-B0T-10	2300/500	630–2050	1050	750	1000 x 400 x 46	180	165	357	201	455	2A	10640
HBG22-B0T-12	2300/500	620–2040	1050	750	1200 x 400 x 46	180	165	359	201	495	2A	10830
HBG22-C0T-10	2300/500	530–1950	1150	750	1000 x 400 x 46	180	165	347	212	458	2A	11060
HBG22-C0T-12	2300/500	520–1940	1150	750	1200 x 400 x 46	180	165	349	204	514	2A	11240
HBG22-D0T-10	2300/500	540–2070	1250	750	1000 x 400 x 46	180	165	347	212	468	2A	11500
HBG22-D0T-12	2300/500	530–2060	1250	750	1200 x 400 x 46	180	165	349	204	524	2A	11650

* Opening range measured across arm tips

HBG-T**2600 kg
3000 kg**

Multi-purpose clamp with rubber-faced arms

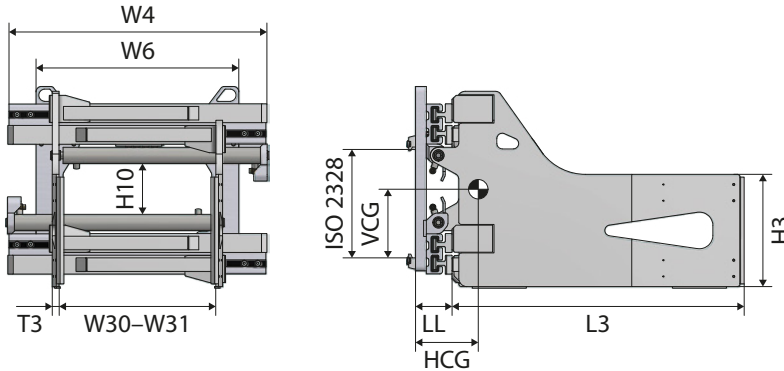

Product info

- W6 – Minimum carriage width
- With valve block sideshifter



Model	Capacity	W30–W31*	W4	W6	Arms L3 x H3 x T3	H10	LL	HCG	VCG	Weight	ISO 2328	RRP
	kg/mm											mm
HBG26-A03T-10	2600/500	520–1830	1050	750	1000 x 400 x 46	180	165	357	201	455	3A	10900
HBG26-A03T-12	2600/500	510–1820	1050	750	1200 x 400 x 46	180	165	358	201	498	3A	11050
HBG26-B03T-10	2600/500	640–2170	1150	750	1000 x 400 x 46	180	165	347	212	458	3A	11350
HBG26-B03T-12	2600/500	630–2160	1150	750	1200 x 400 x 46	180	165	350	212	503	3A	11490
HBG26-C03T-10	2600/500	500–1990	1250	820	1000 x 400 x 46	180	165	337	205	475	3A	11770
HBG26-C03T-12	2600/500	490–1980	1250	820	1200 x 400 x 46	180	165	339	205	515	3A	11900
HBG26-D03T-10	2600/500	640–2290	1320	820	1000 x 400 x 46	180	165	327	200	495	3A	11660
HBG26-D03T-12	2600/500	630–2280	1320	820	1200 x 400 x 46	180	165	329	200	535	3A	11820
HBG30-A0T-12	3000/500	600–2060	1150	870	1200 x 400 x 51	175	203	368	254	851	3A	13740
HBG30-A0T-14	3000/500	590–2050	1150	870	1400 x 400 x 51	175	203	413	239	894	3A	14030
HBG30-B0T-12	3000/500	490–1960	1250	870	1200 x 400 x 51	175	203	364	239	882	3A	14100
HBG30-B0T-14	3000/500	480–1950	1250	870	1400 x 400 x 51	175	203	406	239	912	3A	14480
HBG30-C0T-12	3000/500	610–2270	1320	870	1200 x 400 x 51	175	203	359	239	897	3A	14760
HBG30-C0T-14	3000/500	600–2260	1320	870	1400 x 400 x 51	175	203	399	239	928	3A	15160

* Opening range measured across arm tips

Options

	RRP
	Euro
Separate sideshifter: 100 + 100 mm for ISO/FEM 2	1330
Separate sideshifter: 100 + 100 mm for ISO/FEM 3	1800
2 hydraulic functions – Independent arm control	640
Quick-release lower mountings, class 2 or class 3	605
Frame bumper	260

Available on request

- Different arm dimensions
- Class B mounting arms
- Load backrest
- Models without sideshifter
- 360° rotating models

Advantages

- Fully protected valve and high-grade steel for long life
- Synchronised arm movements
- Rubber-lined arms
- Expertly manufactured
- High piston rods durability thanks to improved pistons joints
- Increased manoeuvrability in confined spaces
- Greater versatility

Open control valve

OCV

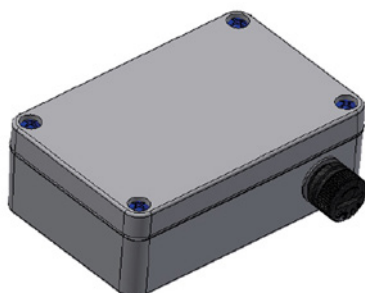

Features

- CAM attachments® Open control valve provides an added level of security to prevent accidental load dropping
- In the event that the opening lever is operated accidentally, the CAM attachments® open control valve prevents the opening of the arms of the equipment

Code and price

[V152.12.KIT.C](#)

Price on request

Included

- Valve complete with body, cartridge, solenoid 12 V
- Junction box for relay and fuse holder
- Illuminated green button

Optional items

- Current converter DC-DC: 80 V–12 V

Technical data

Bale clamps

Model	Clamping						Sideshifting						Hydraulic functions
	Operating pressure			Oil flow rate			Operating pressure			Oil flow rate			
	Min.	Recommended	Max.	Min.	Recommended	Max.	Min.	Recommended	Max.	Min.	Recommended	Max.	
HB10T – HB22T	80	160	180	15	25	40	130	160	220	4	10	15	2
HB26T	100	160	180	18	25	45	130	160	220	6	12	20	2
HB30T – HB42T	100	160	180	18	25	55	130	160	220	7	14	20	2
HB45T – HB80T	120	160	180	20	25	55	130	160	220	7	14	25	2
HBG10T – HBG22T	80	160	180	15	25	40	130	160	220	4	10	15	2
HBG26T	80	160	180	18	25	45	130	160	220	6	12	20	2
HBG30T	80	160	180	18	25	55	130	160	220	7	14	20	2
HBC16T	80	160	180	15	25	40	130	160	220	4	10	15	2
HBC22T	100	160	180	18	25	45	130	160	220	6	12	20	2
HBC26T – HBC35T	100	160	180	18	25	55	130	160	220	7	14	20	2
HBC42T – HBC80T	120	160	180	20	25	55	130	160	220	7	14	25	2

Model	Clamping						Rotating						Hydraulic functions
	Operating pressure			Oil flow rate			Operating pressure			Oil flow rate			
	Min.	Recommended	Max.	Min.	Recommended	Max.	Min.	Recommended	Max.	Min.	Recommended	Max.	
HBR10 – HBR22	80	160	180	15	25	40	130	160	220	20	30	40	2
HBR26	80	160	180	18	25	45	130	160	180	25	40	65	2
HBR30 – HBR42	100	160	180	20	25	55	130	160	180	25	40	65	2

Notes

A series of horizontal dotted lines for writing notes.



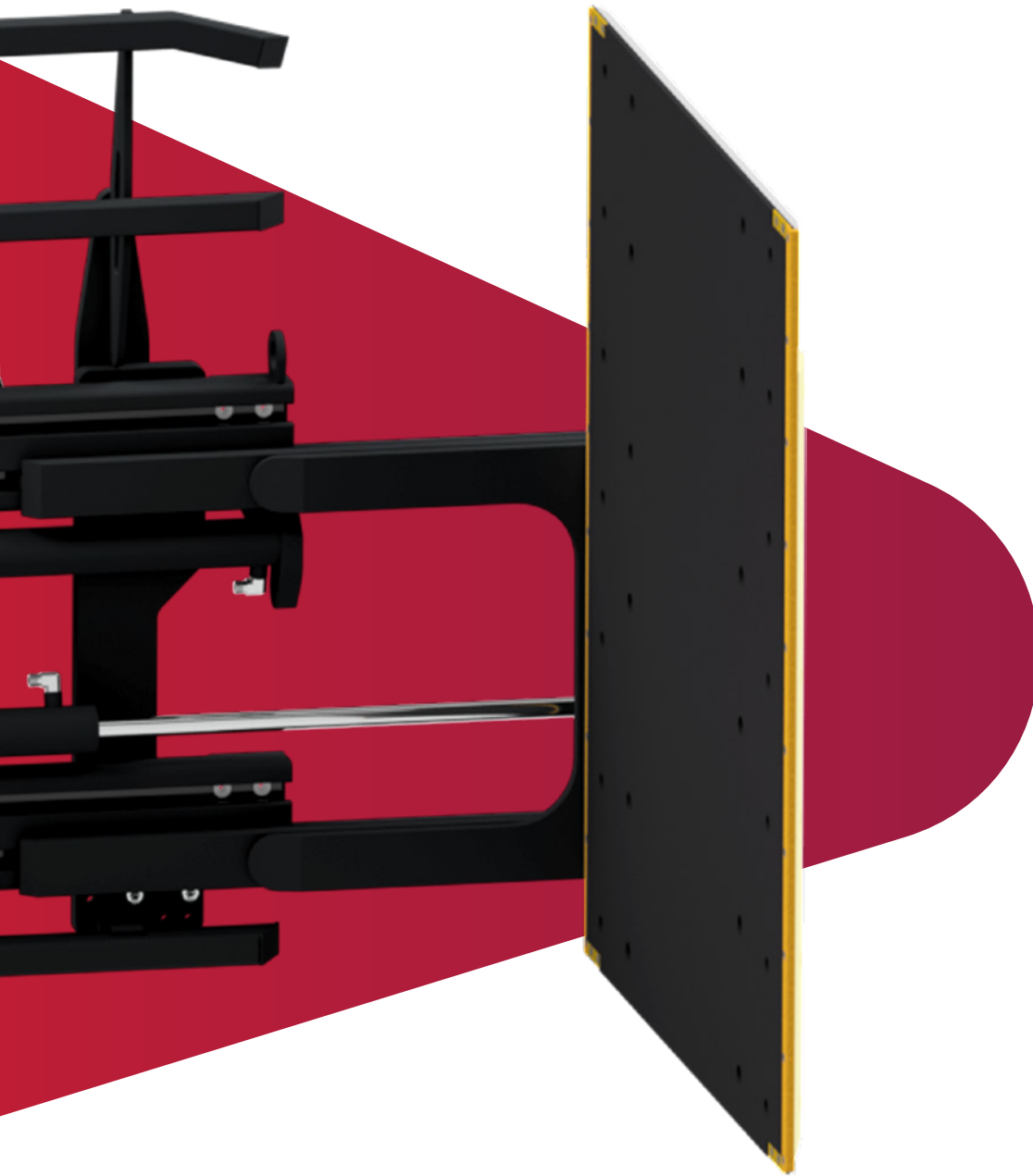

8. Appliance and carton clamps

Appliance and carton clamps are mainly used to safely handle large electronic appliances such as washing machines or ovens. They are specially designed to handle these goods without damaging them.

HEWA-T

1000 kg
2170 kg

Appliance and carton clamp – single articulating pads

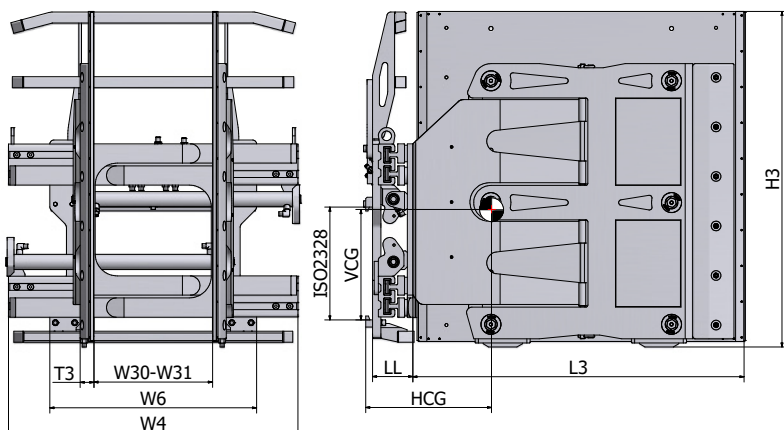

Product info

- W6 – Minimum carriage width
- Models with valve block sideshifter
- Rubberised pads
- Flow divider and regenerative valve
- With alignment bar
- Aluminum pads achieves better distribution of clamping force as well as remarkable low weight. Slim profile of the arms for quick and safe handling even in confined spaces.
- New joint design with patented CAM pads that allow a perfect distribution of the clamping force over the entire surface of the pad, thanks to an easy adjustment of the threaded pads that impact on the curvature of the jaw.
- Aluminum pads achieves better distribution of clamping force as well as remarkable low weight.
- Slim profile of the arms for quick and safe handling even in confined spaces.



Model	Capacity	W30–W31*	W4	W6	Arms L3 x H3 x T3	H10	LL	HCG	VCG	Weight	ISO 2328	RRP
												Euro
HEWA14-A0T-12012	1170/600	450–1680	950	750	1200 x 1220 x 55	205	146	435	398	686	2A	14290
HEWA14-A0T-13012	1080/650	450–1680	950	750	1300 x 1220 x 55	205	146	471	401	730	2A	14950
HEWA14-A0T-13512	1040/675	450–1680	950	750	1350 x 1220 x 55	205	146	479	401	757	2A	15280
HEWA14-A0T-14012	1000/700	450–1680	950	750	1400 x 1220 x 55	205	146	503	402	772	2A	15610
HEWA14-B0T-12012	1170/600	420–1760	1050	750	1200 x 1220 x 55	205	146	430	399	699	2A	14540
HEWA14-B0T-13012	1080/650	420–1760	1050	750	1300 x 1220 x 55	205	146	466	402	735	2A	15200
HEWA14-B0T-13512	1040/675	420–1760	1050	750	1350 x 1220 x 55	205	146	474	402	770	2A	15530
HEWA14-B0T-14012	1000/700	420–1760	1050	750	1400 x 1220 x 55	205	146	498	403	785	2A	15860
HEWA14-B1T-12012	1170/600	590–1970	1050	750	1200 x 1220 x 55	205	146	430	399	705	2A	14660
HEWA14-B1T-13012	1080/650	590–1970	1050	750	1300 x 1220 x 55	205	146	466	402	749	2A	15320
HEWA14-B1T-13512	1040/675	590–1970	1050	750	1350 x 1220 x 55	205	146	474	402	776	2A	15660
HEWA14-B1T-14012	1000/700	590–1970	1050	750	1400 x 1220 x 55	205	146	498	403	791	2A	15990
HEWA14-B2T-12012	1170/600	380–1620	1050	750	1200 x 1220 x 55	205	146	430	398	703	2A	14660
HEWA14-B2T-13012	1080/650	380–1620	1050	750	1300 x 1220 x 55	205	146	466	401	747	2A	15320
HEWA14-B2T-13512	1040/675	380–1620	1050	750	1350 x 1220 x 55	205	146	474	401	774	2A	15660
HEWA14-B2T-14012	1000/700	380–1620	1050	750	1400 x 1220 x 55	205	146	498	402	789	2A	15990
HEWA14-B3T-12012	1170/600	500–1840	1050	750	1200 x 1220 x 55	205	146	430	398	702	2A	14660
HEWA14-B3T-13012	1080/650	500–1840	1050	750	1300 x 1220 x 55	205	146	466	401	746	2A	15320
HEWA14-B3T-13512	1040/675	500–1840	1050	750	1350 x 1220 x 55	205	146	474	401	773	2A	15660
HEWA14-B3T-14012	1000/700	500–1840	1050	750	1400 x 1220 x 55	205	146	498	402	788	2A	15990
HEWA14-C0T-12012	1170/600	460–1920	1150	750	1200 x 1220 x 55	205	146	425	397	715	2A	14910
HEWA14-C0T-13012	1080/650	460–1920	1150	750	1300 x 1220 x 55	205	146	461	400	759	2A	15580
HEWA14-C0T-13512	1040/675	460–1920	1150	750	1350 x 1220 x 55	205	146	473	422	778	2A	15910
HEWA14-C0T-14012	1000/700	460–1920	1150	750	1400 x 1220 x 55	205	146	493	401	801	2A	16240
HEWA14-D0T-12012	1170/600	530–2230	1320	750	1200 x 1220 x 55	205	146	420	396	730	2A	15170
HEWA14-D0T-13012	1080/650	530–2230	1320	750	1300 x 1220 x 55	205	146	456	399	774	2A	15830
HEWA14-D0T-13512	1040/675	530–2230	1320	750	1350 x 1220 x 55	205	146	462	420	798	2A	16160
HEWA14-D0T-14012	1000/700	530–2230	1320	750	1400 x 1220 x 55	205	146	488	400	816	2A	16490

* Opening range measured across arm tips

Appliance and carton clamp – single articulating pads

HEWA-T

1000 kg
2170 kg

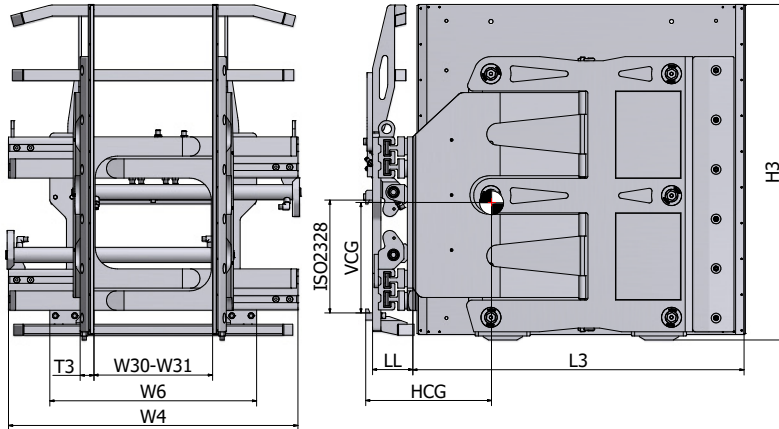

Product info

- W6 – Minimum carriage width
- Models with valve block sideshifter
- Rubberised pads
- Flow divider and regenerative valve
- With alignment bar
- Aluminum pads achieves better distribution of clamping force as well as remarkable low weight. Slim profile of the arms for quick and safe handling even in confined spaces.
- New joint design with patented CAM pads that allow a perfect distribution of the clamping force over the entire surface of the pad, thanks to an easy adjustment of the threaded pads that impact on the curvature of the jaw.
- Aluminum pads achieves better distribution of clamping force as well as remarkable low weight.
- Slim profile of the arms for quick and safe handling even in confined spaces.



Model	Capacity	W30–W31*	W4	W6	Arms L3 x H3 x T3	H10	LL	HCG	VCG	Weight	ISO 2328	RRP
	kg/mm											mm
HEWA14-EOT-12012	1170/600	450–2200	1450	850	1200 x 1220 x 55	205	146	415	395	745	2A	15420
HEWA14-EOT-13012	1080/650	450–2200	1450	850	1300 x 1220 x 55	205	146	451	398	789	2A	16080
HEWA14-EOT-13512	1040/675	450–2200	1450	850	1350 x 1220 x 55	205	146	452	419	818	2A	16410
HEWA14-EOT-14012	1000/700	450–2200	1450	850	1400 x 1220 x 55	205	146	483	399	831	2A	16740
HEWA14-FOT-12012	1170/600	550–2550	1600	850	1200 x 1220 x 55	205	146	410	394	760	2A	15790
HEWA14-FOT-13012	1080/650	550–2550	1600	850	1300 x 1220 x 55	205	146	446	397	804	2A	16450
HEWA14-FOT-13512	1040/675	550–2550	1600	850	1350 x 1220 x 55	205	146	454	397	831	2A	16780
HEWA14-FOT-14012	1000/700	550–2550	1600	850	1400 x 1220 x 55	205	146	478	398	846	2A	17110
HEWA18-AOT-12012	1500/600	450–1680	950	750	1200 x 1220 x 55	195	146	435	398	689	2A	15180
HEWA18-AOT-13012	1385/650	450–1680	950	750	1300 x 1220 x 55	195	146	471	401	733	2A	15840
HEWA18-AOT-13512	1335/675	450–1680	950	750	1350 x 1220 x 55	195	146	479	401	760	2A	16180
HEWA18-AOT-14012	1290/700	450–1680	950	750	1400 x 1220 x 55	195	146	503	402	775	2A	16500
HEWA18-BOT-12012	1500/600	440–1780	1050	750	1200 x 1220 x 55	195	146	430	399	702	2A	15430
HEWA18-BOT-13012	1385/650	440–1780	1050	750	1300 x 1220 x 55	195	146	466	402	746	2A	16090
HEWA18-BOT-13512	1335/675	440–1780	1050	750	1350 x 1220 x 55	195	146	474	402	773	2A	16430
HEWA18-BOT-14012	1290/700	440–1780	1050	750	1400 x 1220 x 55	195	146	498	403	788	2A	16750
HEWA18-B1T-12012	1500/600	590–1970	1050	750	1200 x 1220 x 55	195	146	430	399	708	2A	15430
HEWA18-B1T-13012	1385/650	590–1970	1050	750	1300 x 1220 x 55	195	146	466	402	752	2A	16090
HEWA18-B1T-13512	1335/675	590–1970	1050	750	1350 x 1220 x 55	195	146	473	423	774	2A	16430
HEWA18-B1T-14012	1290/700	590–1970	1050	750	1400 x 1220 x 55	195	146	498	403	794	2A	16750
HEWA18-B2T-12012	1500/600	380–1620	1050	750	1200 x 1220 x 55	195	146	430	399	706	2A	15430
HEWA18-B2T-13012	1385/650	380–1620	1050	750	1300 x 1220 x 55	195	146	466	402	750	2A	16090
HEWA18-B2T-13512	1335/675	380–1620	1050	750	1350 x 1220 x 55	195	146	473	423	761	2A	16430
HEWA18-B2T-14012	1290/700	380–1620	1050	750	1400 x 1220 x 55	195	146	498	403	792	2A	16750
HEWA18-B3T-12012	1500/600	480–1860	1050	750	1200 x 1220 x 55	195	146	430	399	705	2A	15430
HEWA18-B3T-13012	1385/650	480–1860	1050	750	1300 x 1220 x 55	195	146	466	402	749	2A	16090
HEWA18-B3T-13512	1335/675	480–1860	1050	750	1350 x 1220 x 55	195	146	474	402	776	2A	16430
HEWA18-B3T-14012	1290/700	480–1860	1050	750	1400 x 1220 x 55	195	146	498	403	791	2A	16750
HEWA18-COT-12012	1500/600	460–1930	1150	750	1200 x 1220 x 55	195	146	425	397	718	2A	15680

* Opening range measured across arm tips

HEWA-T

1000 kg
2170 kg

Appliance and carton clamp – single articulating pads

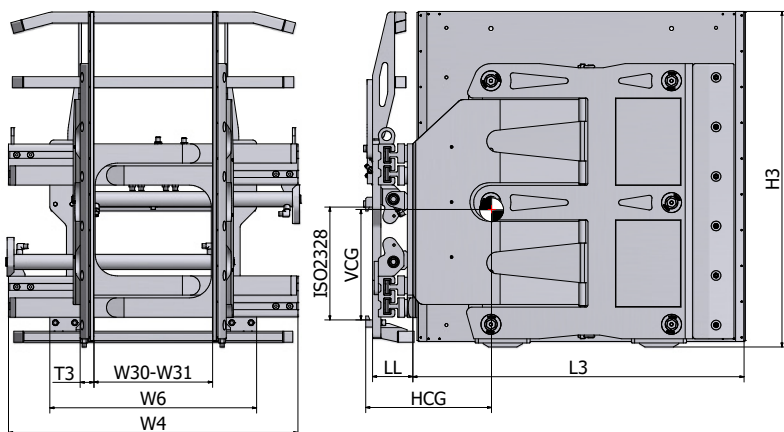

Product info

- W6 – Minimum carriage width
- Models with valve block sideshifter
- Rubberised pads
- Flow divider and regenerative valve
- With alignment bar
- Aluminum pads achieves better distribution of clamping force as well as remarkable low weight. Slim profile of the arms for quick and safe handling even in confined spaces.
- New joint design with patented CAM pads that allow a perfect distribution of the clamping force over the entire surface of the pad, thanks to an easy adjustment of the threaded pads that impact on the curvature of the jaw.
- Aluminum pads achieves better distribution of clamping force as well as remarkable low weight.
- Slim profile of the arms for quick and safe handling even in confined spaces.



Model	Capacity	W30–W31*	W4	W6	Arms L3 x H3 x T3	H10	LL	HCG	VCG	Weight	ISO 2328	RRP
	kg/mm											mm
HEWA18-COT-13012	1385/650	460–1930	1150	750	1300 x 1220 x 55	195	146	461	400	762	2A	16340
HEWA18-COT-13512	1335/675	460–1930	1150	750	1350 x 1220 x 55	195	146	469	400	789	2A	16680
HEWA18-COT-14012	1290/700	460–1930	1150	750	1400 x 1220 x 55	195	146	493	401	804	2A	17010
HEWA18-DOT-12012	1500/600	530–2230	1320	750	1200 x 1220 x 55	195	146	420	396	733	2A	15930
HEWA18-DOT-13012	1385/650	530–2230	1320	750	1300 x 1220 x 55	195	146	456	399	777	2A	16600
HEWA18-DOT-13512	1335/675	530–2230	1320	750	1350 x 1220 x 55	195	146	464	399	804	2A	16930
HEWA18-DOT-14012	1290/700	530–2230	1320	750	1400 x 1220 x 55	195	146	488	400	819	2A	17260
HEWA18-EOT-12012	1500/600	450–2200	1450	850	1200 x 1220 x 55	195	146	415	395	748	2A	16190
HEWA18-EOT-13012	1385/650	450–2200	1450	850	1300 x 1220 x 55	195	146	451	398	792	2A	16850
HEWA18-EOT-13512	1335/675	450–2200	1450	850	1350 x 1220 x 55	195	146	459	398	819	2A	17180
HEWA18-EOT-14012	1290/700	450–2200	1450	850	1400 x 1220 x 55	195	146	483	399	834	2A	17510
HEWA18-FOT-12012	1500/600	550–2550	1600	850	1200 x 1220 x 55	195	146	410	394	763	2A	16560
HEWA18-FOT-13012	1385/650	550–2550	1600	850	1300 x 1220 x 55	195	146	446	397	807	2A	17220
HEWA18-FOT-13512	1335/675	550–2550	1600	850	1350 x 1220 x 55	195	146	454	397	834	2A	17550
HEWA18-FOT-14012	1290/700	550–2550	1600	850	1400 x 1220 x 55	195	146	478	398	849	2A	17880
HEWA22-AOT-12012	1835/600	450–1630	950	750	1200 x 1220 x 55	185	146	437	403	714	2A	16690
HEWA22-AOT-13012	1695/650	450–1630	950	750	1300 x 1220 x 55	185	146	473	406	758	2A	17350
HEWA22-AOT-13512	1630/675	450–1630	950	750	1350 x 1220 x 55	185	146	481	406	785	2A	17680
HEWA22-AOT-14012	1575/700	450–1630	950	750	1400 x 1220 x 55	185	146	505	407	800	2A	18010
HEWA22-BOT-12012	1835/600	440–1780	1050	750	1200 x 1220 x 55	185	146	432	404	727	2A	16940
HEWA22-BOT-13012	1695/650	440–1780	1050	750	1300 x 1220 x 55	185	146	468	407	771	2A	17600
HEWA22-BOT-13512	1630/675	440–1780	1050	750	1350 x 1220 x 55	185	146	476	407	798	2A	17930
HEWA22-BOT-14012	1575/700	440–1780	1050	750	1400 x 1220 x 55	185	146	500	408	813	2A	18260
HEWA22-B1T-12012	1835/600	590–1970	1050	750	1200 x 1220 x 55	185	146	432	404	733	2A	16940
HEWA22-B1T-13012	1695/650	590–1970	1050	750	1300 x 1220 x 55	185	146	468	407	777	2A	17600
HEWA22-B1T-13512	1630/675	590–1970	1050	750	1350 x 1220 x 55	185	146	475	428	799	2A	17930
HEWA22-B1T-14012	1575/700	590–1970	1050	750	1400 x 1220 x 55	185	146	500	408	819	2A	18260
HEWA22-B2T-12012	1835/600	380–1620	1050	750	1200 x 1220 x 55	185	146	432	404	731	2A	16940

* Opening range measured across arm tips

Appliance and carton clamp – single articulating pads

HEWA-T

1000 kg
2170 kg

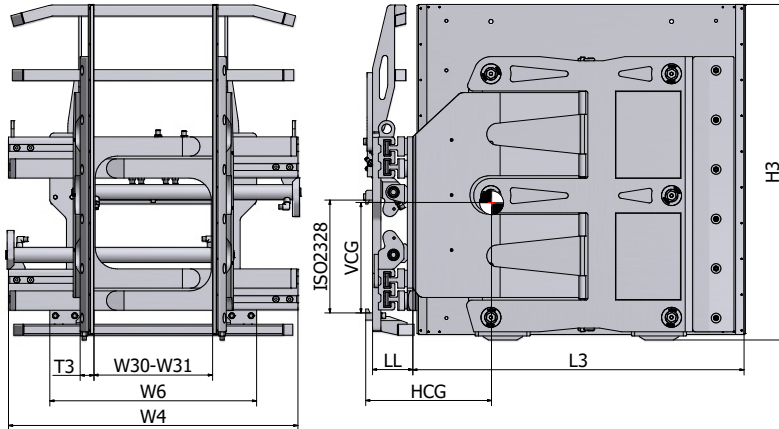

Product info

- W6 – Minimum carriage width
- Models with valve block sideshifter
- Rubberised pads
- Flow divider and regenerative valve
- With alignment bar
- Aluminum pads achieves better distribution of clamping force as well as remarkable low weight. Slim profile of the arms for quick and safe handling even in confined spaces.
- New joint design with patented CAM pads that allow a perfect distribution of the clamping force over the entire surface of the pad, thanks to an easy adjustment of the threaded pads that impact on the curvature of the jaw.
- Aluminum pads achieves better distribution of clamping force as well as remarkable low weight.
- Slim profile of the arms for quick and safe handling even in confined spaces.



Model	Capacity kg/mm	W30–W31* mm	W4 mm	W6 mm	Arms L3 x H3 x T3 mm	H10 mm	LL mm	HCG mm	VCG mm	Weight kg	ISO 2328	RRP
												Euro
HEWA22-B2T-13012	1695/650	380–1620	1050	750	1300 x 1220 x 55	185	146	468	407	775	2A	17600
HEWA22-B2T-13512	1630/675	380–1620	1050	750	1350 x 1220 x 55	185	146	475	428	786	2A	17930
HEWA22-B2T-14012	1575/700	380–1620	1050	750	1400 x 1220 x 55	185	146	500	408	817	2A	18260
HEWA22-B3T-12012	1835/600	500–1840	1050	750	1200 x 1220 x 55	185	146	432	404	730	2A	16940
HEWA22-B3T-13012	1695/650	500–1840	1050	750	1300 x 1220 x 55	185	146	468	407	774	2A	17600
HEWA22-B3T-13512	1630/675	500–1840	1050	750	1350 x 1220 x 55	185	146	476	407	801	2A	17930
HEWA22-B3T-14012	1575/700	500–1840	1050	750	1400 x 1220 x 55	185	146	500	408	816	2A	18260
HEWA22-C0T-12012	1835/600	460–1920	1150	750	1200 x 1220 x 55	185	146	427	402	743	2A	17190
HEWA22-C0T-13012	1695/650	460–1920	1150	750	1300 x 1220 x 55	185	146	463	405	787	2A	17850
HEWA22-C0T-13512	1630/675	460–1920	1150	750	1350 x 1220 x 55	185	146	471	405	814	2A	18180
HEWA22-C0T-14012	1575/700	460–1920	1150	750	1400 x 1220 x 55	185	146	495	406	829	2A	18510
HEWA22-D0T-12012	1835/600	530–2230	1320	750	1200 x 1220 x 55	185	146	422	401	758	2A	17440
HEWA22-D0T-13012	1695/650	530–2230	1320	750	1300 x 1220 x 55	185	146	458	404	802	2A	18100
HEWA22-D0T-13512	1630/675	530–2230	1320	750	1350 x 1220 x 55	185	146	466	404	829	2A	18430
HEWA22-D0T-14012	1575/700	530–2230	1320	750	1400 x 1220 x 55	185	146	490	405	844	2A	18760
HEWA22-E0T-12012	1835/600	450–2200	1450	850	1200 x 1220 x 55	185	146	417	400	773	2A	17690
HEWA22-E0T-13012	1695/650	450–2200	1450	850	1300 x 1220 x 55	185	146	453	403	817	2A	18350
HEWA22-E0T-13512	1630/675	450–2200	1450	850	1350 x 1220 x 55	185	146	461	403	844	2A	18680
HEWA22-E0T-14012	1575/700	450–2200	1450	850	1400 x 1220 x 55	185	146	485	404	859	2A	19010
HEWA22-F0T-12012	1835/600	550–2550	1600	850	1200 x 1220 x 55	185	146	412	399	788	2A	18060
HEWA22-F0T-13012	1695/650	550–2550	1600	850	1300 x 1220 x 55	185	146	448	402	832	2A	18720
HEWA22-F0T-13512	1630/675	550–2550	1600	850	1350 x 1220 x 55	185	146	456	402	859	2A	19050
HEWA22-F0T-14012	1575/700	550–2550	1600	850	1400 x 1220 x 55	185	146	480	403	874	2A	19380
HEWA26-F0T-12012	2170/600	550–2550	1600	850	1200 x 1220 x 55	165	165	400	392	903	3A	19940
HEWA26-F0T-13012	2000/650	550–2550	1600	850	1300 x 1220 x 55	165	165	436	395	947	3A	20600
HEWA26-F0T-13512	1925/675	550–2550	1600	850	1350 x 1220 x 55	165	165	464	395	982	3A	20930
HEWA26-F0T-14012	1860/700	550–2550	1600	850	1400 x 1220 x 55	165	165	488	396	1007	3A	21260
HEWA26-G0T-12012	2170/600	560–2880	2000	850	1200 x 1220 x 55	165	165	393	396	950	3A	20940

* Opening range measured across arm tips

HEWA-T

**2000 kg
1860 kg**

Appliance and carton clamp – single articulating pads

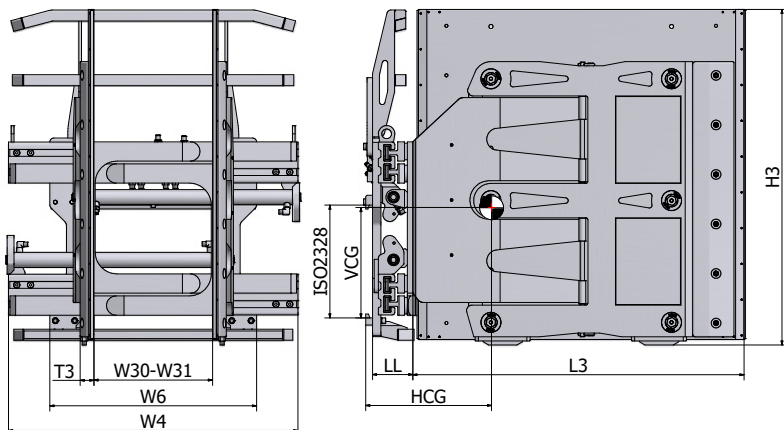

Product info

- W6 – Minimum carriage width
- Models with valve block sideshifter
- Rubberised pads
- Flow divider and regenerative valve
- With alignment bar
- Aluminum pads achieves better distribution of clamping force as well as remarkable low weight. Slim profile of the arms for quick and safe handling even in confined spaces.
- New joint design with patented CAM pads that allow a perfect distribution of the clamping force over the entire surface of the pad, thanks to an easy adjustment of the threaded pads that impact on the curvature of the jaw.
- Aluminum pads achieves better distribution of clamping force as well as remarkable low weight.
- Slim profile of the arms for quick and safe handling even in confined spaces.



Model	Capacity	W30–W31*	W4	W6	Arms L3 x H3 x T3	H10	LL	HCG	VCG	Weight	ISO 2328	RRP
												Euro
HEWA26-G0T-13012	2000/650	560–2880	2000	850	1300 x 1220 x 55	165	165	429	397	994	3A	21600
HEWA26-G0T-13512	1925/675	560–2880	2000	850	1350 x 1220 x 55	165	165	457	397	1029	3A	21930
HEWA26-G0T-14012	1860/700	560–2880	2000	850	1400 x 1220 x 55	165	165	481	398	1054	3A	22260

* Opening range measured across arm tips

Options

	RRP
	Euro
Separate sideshifter: 100 + 100 mm for ISO/FEM 2	1330
Separate sideshifting 100 + 100 mm for ISO/FEM 3	1800
2 hydraulic functions – Independent arm control	640
Quick-release lower mountings, class 2 or class 3	605

Available on request

- Different contact pads
- Other opening ranges
- Models without sideshifter
- Pads with lower rubber plate
- Pads with lower steel plate
- Load backrest and arm extensions for extended tier handling
- Model with triple articulating arms (HEWD)
- Model with triple articulating right arm and single articulating left arm (HEWDA)
- Model with single articulating right arm and fixed left arm (HEWAF)
- Model with triple articulating right arm and fixed arm (HEWDF)
- Model with automatic or manual pressure regulator

Advantages

- Expertly manufactured
- Superior mechanical strength
- Easy and precise pads regulation by a patented new system
- Highly performing dedicated valve
- Durable piston rods by new pistons joints

Auxiliary accessories

	RRP
	Euro
Different contact pad (HE.DN)	On request
Four point tester	On request

Intelligent appliance clamp

HEXA

1580 kg
1860 kg

Product info

- W6 – Minimum carriage width
- Models with valve block sideshifter
- Welded arms
- Smartgripper system: automatic adjustment of the clamping force
- Aluminum pads achieves better distribution of clamping force as well as remarkable low weight. Slim profile of the arms for quick and safe handling even in confined spaces.
- New joint design with patented CAM pads that allow a perfect distribution of the clamping force over the entire surface of the pad, thanks to an easy adjustment of the threaded pads that impact on the curvature of the jaw.
- Aluminum pads achieves better distribution of clamping force as well as remarkable low weight. Slim profile of the arms for quick and safe handling even in confined spaces.

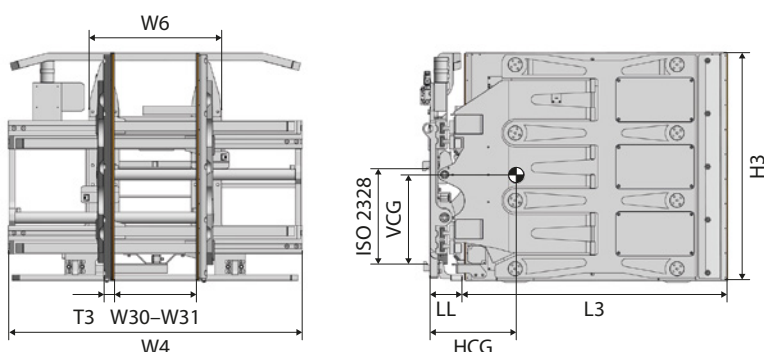

Model	Capacity	W30-W31*	W4	W6	Arms L3 x H3 x T3	H10	LL	HCG	VCG	Weight	ISO 2328	RRP
	kg/mm	mm	mm	mm	mm	mm	mm	mm	mm	kg		Euro
HEXA22-A0T-13812	1580/700	430/2240	1550	1000	1400 x 1220 x 55	230	165	461	457	1055	2A	37200
HEXA26-A0T-13812	1860/700	430/2240	1550	1000	1400 x 1220 x 55	230	165	455	458	1060	3A	39000

* Opening range measured across arm tips

Please let us know your forklift voltage when placing your order.

Options

	RRP
	Euro
Separate sideshifter: 100 + 100 mm for ISO/FEM 2	On request
Separate sideshifter: 100 + 100 mm for ISO/FEM 3	On request
Class 2 or class 3 quick-release lower mountings	On request

Available on request

- Different voltage power supply
- Models without sideshifter
- Different contact pads
- Other opening ranges
- Removable Load backrest on frame
- Removable Load backrest on plate
- Manometer

Advantages

- Expertly manufactured
- Superior mechanical strength
- No manual adjustments are needed
- Easy and precise pads regulation by a patented new system
- Highly performing dedicated valve
- Durable piston rods by new pistons joints

Auxiliary accessories

	RRP
	Euro
Different contact pad (HE.DN)	On request
Four point tester	On request

HEF-T**800 kg
1400 kg**

Appliance and carton clamp – rigid pads

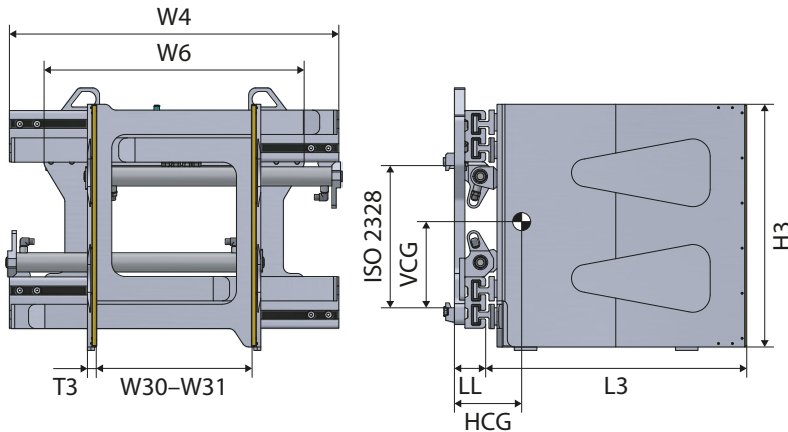
**Product info**

- W6 – Minimum carriage width
- Models with valve block sideshifter
- Welded arms
- Flow divider and regenerative valve



Model	Capacity	W30–W31*	W4	W6	Arms L3 x H3 x T3	H10	LL	HCG	VCG	Weight	ISO 2328	RRP
	kg/mm											mm
HEF08-A0T-07	800/500	430–1600	950	800	700 x 700 x 25	195	140	188	266	348	2A	8710
HEF08-A0T-0710	800/500	430–1600	950	800	700 x 1000 x 25	195	140	173	275	416	2A	9340
HEF08-B0T-07	800/500	460–1740	1050	800	700 x 700 x 25	195	140	188	236	380	2A	8970
HEF08-A0T-0910	800/500	420–1590	950	800	900 x 1000 x 25	195	140	277	319	483	2A	10220
HEF08-A0T-09	800/500	420–1590	950	800	900 x 700 x 25	195	140	283	249	397	2A	9120
HEF08-B0T-0710	800/500	460–1740	1050	800	700 x 1000 x 25	195	140	170	275	423	2A	9640
HEF08-B0T-09	800/500	480–1710	1050	800	900 x 700 x 25	195	140	246	239	432	2A	9420
HEF08-B0T-0910	800/500	480–1710	1050	800	900 x 1000 x 25	195	140	258	319	488	2A	10520
HEF10-AQ0T-0908	1000/500	440–1630	950	800	900 x 800 x 25	195	140	296	295	452	2A	10190
HEF10-AQ0T-0912	1000/500	440–1630	950	800	900 x 1200 x 25	195	140	356	343	563	2A	11520
HEF10-BQ0T-0908	1000/500	400–1650	1050	800	900 x 800 x 25	195	140	292	294	459	2A	10520
HEF10-BQ0T-0912	1000/500	400–1650	1050	800	900 x 1200 x 25	195	140	353	342	570	2A	11850
HEF12-AQ0T-0908	1200/500	480–1580	950	800	900 x 800 x 25	195	140	285	247	480	2A	10920
HEF12-AQ0T-0912	1200/500	480–1580	950	800	900 x 1200 x 25	195	140	344	236	591	2A	12240
HEF12-BQ0T-0908	1200/500	450–1650	1050	800	900 x 800 x 25	195	140	279	247	493	2A	11290
HEF12-BQ0T-0912	1200/500	450–1650	1050	800	900 x 1200 x 25	195	140	339	236	603	2A	12620
HEF14-C1T-07	1400/500	460–1860	1150	800	700 x 700 x 25	195	140	260	232	395	2A	9940
HEF14-C1T-10	1400/500	460–1860	1150	800	1000 x 700 x 25	195	140	265	232	425	2A	10800

* Opening range measured across arm tips

Options

	RRP
	Euro
Separate sideshifter: 100 + 100 mm for ISO/FEM 2	1330
2 hydraulic functions – Independent arm control	640
Quick-release lower mountings, class 2	605

Available on request

- Different contact pads
- Other opening ranges
- Load backrest
- Models without sideshifter
- Manometer
- Model with single articulating right arm and fixed left arm (HEWAF)
- Model with automatic or manual pressure regulator

Appliance and carton clamp – tilting pads

HETP

300 kg
750 kg

Product info

- W6 – Minimum carriage width
- Models with valve block sidsifter
- Welded arms
- Rubber plate
- Reinforced bushings on the arms and articulation for long durability
- Without sidsift

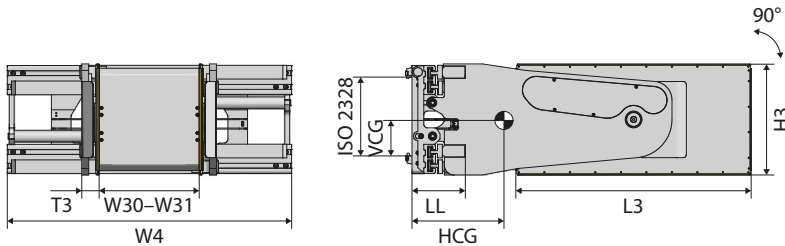

Model	Capacity	W30–W31*	W4	W6	Arms L3 x H3 x T3	LL	HCG	VCG	Weight	ISO 2328	RRP
	kg/mm										mm
Model 90°											
HETP06-B0-0512	300/1000	540/2160	1250	1000	1200 x 550 x 90	270	460	180	715	2A	On request
HETP10-C0-0512	500/970	510/2310	1450	1000	1200 x 550 x 90	270	475	180	735	2A	On request
HETP14-D0-0512	750/935	610/2450	1600	1000	1200 x 550 x 90	270	480	180	765	2A	On request
Model 180°											
HETP06-B0-0712.18	300/1000	540/2160	1250	1000	1200 x 750 x 90	270	460	180	815	2A	On request
HETP10-C0-0712.18	500/970	510/2310	1450	1000	1200 x 700 x 90	270	475	180	830	2A	On request
HETP14-D0-0712.18	750/935	610/2450	1600	1000	1200 x 700 x 90	270	480	180	865	2A	On request

* Opening range measured across arm tips

Options

	RRP
	Euro
Separate sidsifter: 100 + 100 mm for ISO/FEM 2	1145
2 hydraulic functions - Integrated sidsifting	631
2 hydraulic functions – Independent arm control	On request
Class 2 or class 3 quick-release lower mountings	On request

Available on request

- Different contact pads
- Other opening ranges

DD

Digital dynamometer

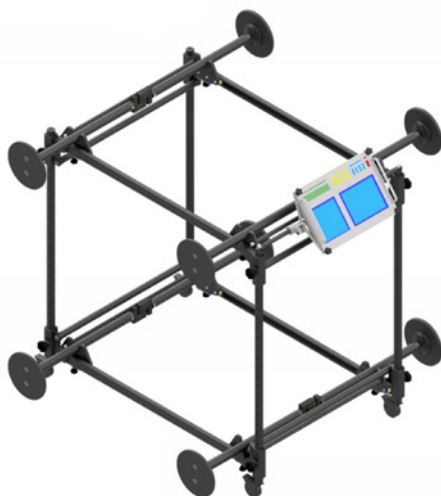

Features

- The HE.DN CAM attachments® dynamometer is an instrument designed and manufactured for measuring the distribution of clamping force on equipment used in the handling of cartons and household appliances

Included

- Digital testing unit with integrated printer
- Portable testing frame

Code and price

[HE.DN](#)

Price on request

Pressure control

PC

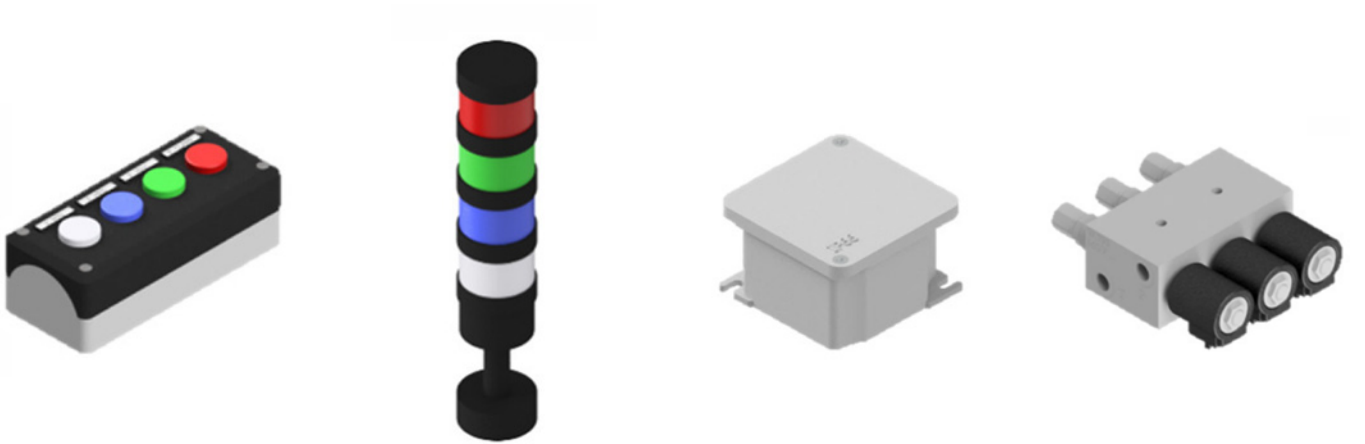

Features

- CAM attachments® pressure control allows you to select between 4 preset and adjustable pressures which allow you to adjust the clamping force of the equipment depending on the load requirements

Code and price

[PC.HE.EV.24V](#)

Price on request

Included

- Keypad
- Light column
- Control board box
- Maximum pressure valve

Optional items

- Current converter DC – DC 80 V – 24 V

Technical data

Appliance and carton clamps

Model	Clamping						Sideshifting						Hydraulic functions
	Operating pressure			Oil flow rate			Operating pressure			Oil flow rate			
	Min.	Recom- mended	Max.	Min.	Recom- mended	Max.	Min.	Recom- mended	Max.	Min.	Recom- mended	Max.	
HEWA-T	60	160	180	15	25	45	130	160	220	7	14	20	2
HED-T	60	160	180	15	25	45	130	160	220	7	14	20	2
HEF-T	60	160	180	15	25	45	130	160	220	7	14	20	2
HEXA-T	60	160	180	15	25	45	130	160	220	7	14	20	2
HETP	60	160	180	15	25	45	130	160	220	7	14	20	2

For forklifts with different pressure and oil flow, contact CAM Attachments

Notes

A series of horizontal dotted lines for writing notes.

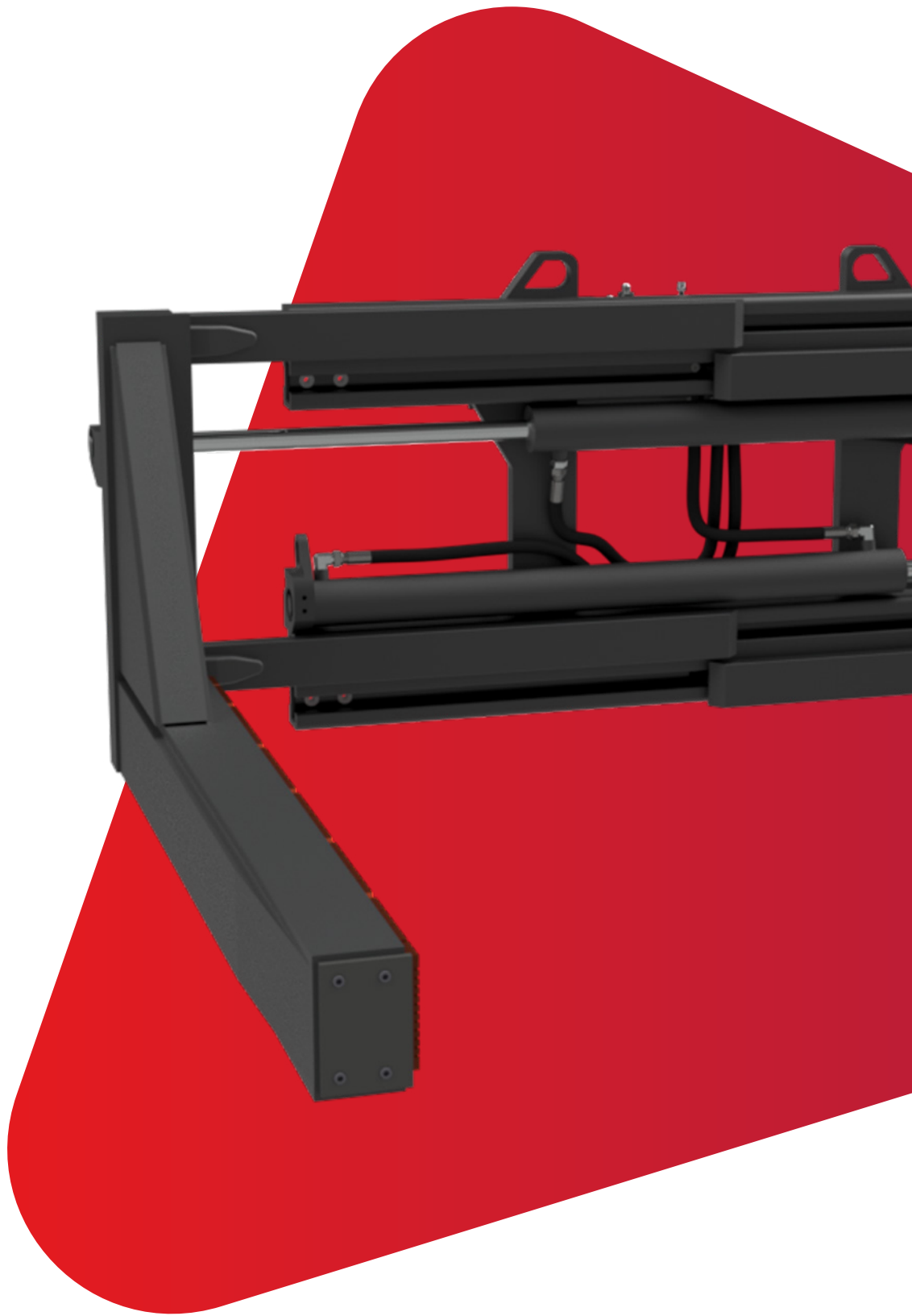

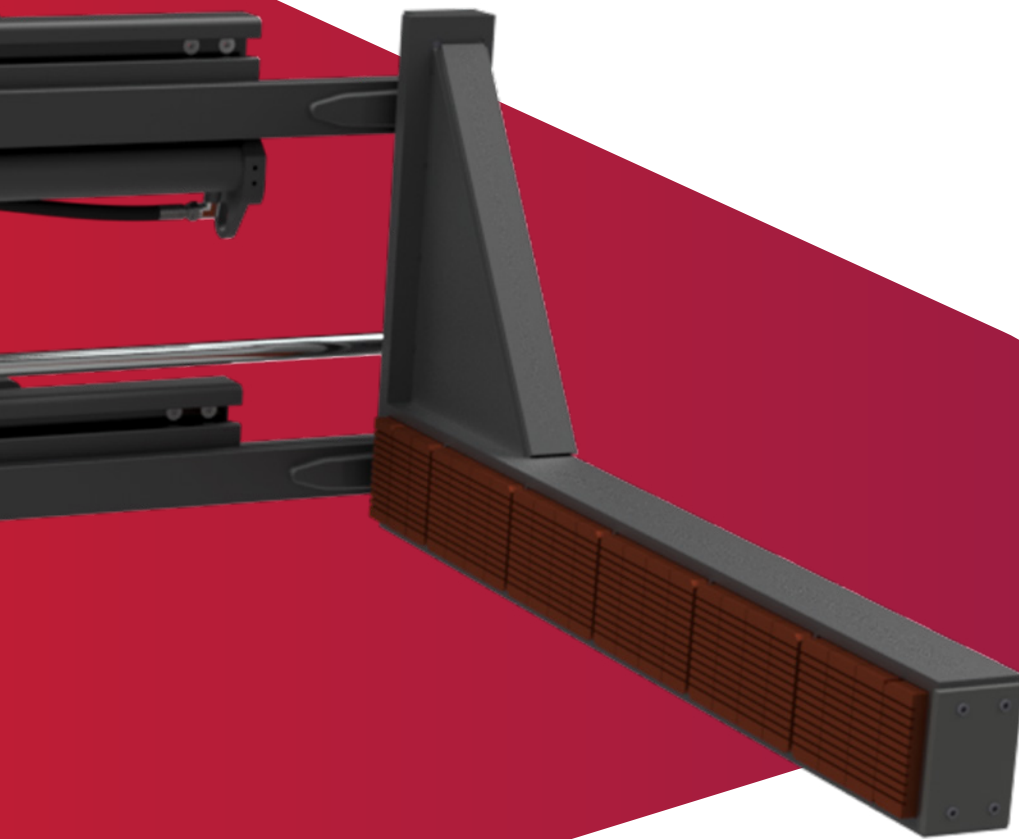

9. Concrete block clamps

Do you often need to handle concrete blocks without using pallets? You can do so with a concrete block clamp! Its clamping arms have a unique rubber cushion that adapts perfectly to the irregular profile of a concrete block or a stack of bricks.

HC

1800 kg
3500 kg

Concrete block clamp – self-compensating arm pads

Product info

- W6 – Minimum carriage width
- Self-regulating polyurethane arm block
- Without sideshifter
- Bolted arms
- Block valve with flow divider for excellent arms synchronization
- Excellent visibility through the frame

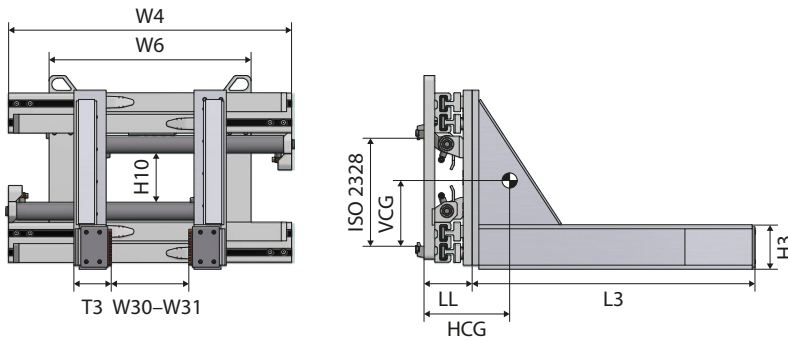

Model	Capacity kg/mm	W30–W31* mm	W4 mm	W6 mm	Arms L3 x H3 x T3 mm	H10 mm	LL mm	HCG mm	VCG mm	Weight kg	ISO 2328	RRP
												Euro
HC18-A0-10	1800/500	250–1440	1050	750	1000 x 160 x 135	185	135	308	173	500	2A	12580
HC22-A0-10	2200/500	350–1770	1150	750	1000 x 160 x 135	180	135	303	165	510	2A	13230
HC22-A0-12	2200/500	350–1770	1150	750	1200 x 160 x 135	180	135	357	165	550	2A	13690
HC22-BQ0-10	2200/500	350–1870	1250	750	1000 x 160 x 135	180	135	302	165	520	2A	13440
HC22-BQ0-12	2200/500	350–1870	1250	750	1200 x 160 x 135	180	135	355	165	560	2A	13900
HC26-A03-10	2600/500	350–1770	1150	750	1000 x 160 x 135	180	137	303	165	529	3A	14380
HC26-A03-12	2600/500	350–1770	1150	750	1200 x 160 x 135	180	137	357	165	566	3A	14840
HC30-A0-12	3000/500	350–1940	1320	850	1200 x 160 x 135	175	215	312	236	768	3A	18290
HC35-BQ0-10	3500/500	360–1750	1150	750	1000 x 160 x 135	175	215	250	236	702	3A	17510
HC35-BQ0-12	3500/500	360–1750	1150	750	1200 x 160 x 135	175	215	307	236	740	3A	18450
HC35-BQ0-13	3500/500	360–1750	1150	750	1300 x 160 x 135	175	215	332	236	755	3A	18870
HC35-CQ0-10	3500/500	420–1920	1250	750	1000 x 160 x 135	175	215	251	236	722	3A	17930
HC35-CQ0-12	3500/500	420–1920	1250	750	1200 x 160 x 135	175	215	306	236	760	3A	18870
HC35-CQ0-13	3500/500	420–1920	1250	750	1300 x 160 x 135	175	215	337	236	775	3A	19290
HC35-A0-12	3500/500	360–1940	1320	850	1200 x 160 x 135	175	215	305	236	780	3A	18500

* Opening range measured across arm tips

Options

	RRP Euro
Separate sideshifter: 100 + 100 mm for ISO/FEM 2	1330
Separate sideshifting 100 + 100 mm for ISO/FEM 3	1800
Separate sideshifter: 100 + 100 mm for ISO/FEM 4	2140
2 hydraulic functions – Independent arm control	640
2 hydraulic functions - Integrated sideshifting	630
Quick-release lower mountings, class 2 or class 3	605
Double max. pressure control valve	685
Frame bumper	260

Available on request

- Different arm dimensions
- Class 4 hooks
- Other openings range

Advantages

- Expertly manufactured
- Superior mechanical strength
- A secure grip around the load
- No more broken loads

See this attachment in action



Concrete block clamp – articulated arm pads

HCA

1800 kg
3500 kg

Product info

- W6 – Minimum carriage width
- Articulated polyurethane arm pads
- Without sideshifter
- Bolted arms

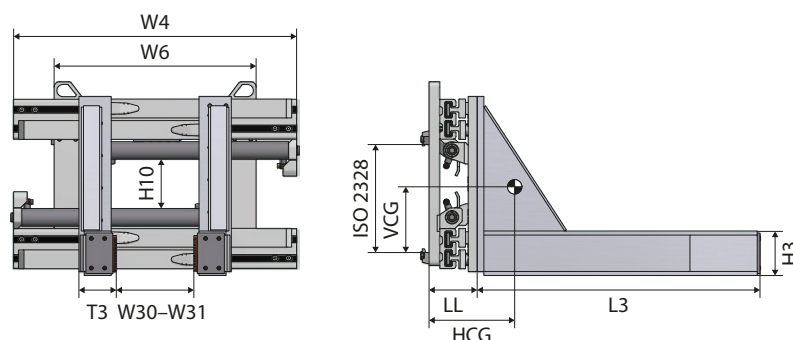

Model	Capacity	W30–W31*	W4	W6	Arms L3 x H3 x T3	H10	LL	HCG	VCG	Weight	ISO 2328	RRP
												Euro
	kg/mm	mm	mm	mm	mm	mm	mm	mm	mm	kg		Euro
HCA18-A0-10	1800/500	250–1440	1050	750	1000 x 120 x 145	185	135	278	188	475	2A	12580
HCA22-A0-10	2200/500	330–1750	1150	750	1000 x 120 x 145	180	135	288	188	480	2A	13230
HCA22-A0-12	2200/500	330–1750	1150	750	1200 x 120 x 145	180	135	289	187	490	2A	13690
HCA22-BQ0-10	2200/500	350–1870	1250	750	1000 x 120 x 145	180	135	317	176	495	2A	13590
HCA22-BQ0-12	2200/500	350–1870	1250	750	1200 x 120 x 145	180	135	370	176	535	2A	13890
HCA26-A03-10	2600/500	330–1750	1150	750	1000 x 120 x 145	180	137	270	200	506	3A	14380
HCA26-A03-12	2600/500	330–1750	1150	750	1200 x 120 x 145	180	137	316	200	526	3A	14840
HCA30-A0-12	3000/500	350–1940	1320	850	1200 x 240 x 145	175	215	321	247	745	3A	18290
HCA35-BQ0-10	3500/500	360–1750	1150	750	1000 x 240 x 145	175	215	265	176	677	3A	17510
HCA35-BQ0-12	3500/500	360–1750	1150	750	1200 x 240 x 145	175	215	322	247	715	3A	18450
HCA35-BQ0-13	3500/500	360–1750	1150	750	1300 x 240 x 145	175	215	347	247	730	3A	18870
HCA35-CQ0-10	3500/500	420–1920	1250	750	1000 x 240 x 145	175	215	266	247	697	3A	17930
HCA35-CQ0-12	3500/500	420–1920	1250	750	1200 x 240 x 145	175	215	321	247	735	3A	18900
HCA35-CQ0-13	3500/500	420–1920	1250	750	1300 x 240 x 145	175	215	352	247	750	3A	19300
HCA35-A0-12	3500/500	360–1940	1320	850	1200 x 240 x 145	175	215	321	247	750	3A	19200

* Opening range measured across arm tips

Options

	RRP
	Euro
Separate sideshifter: 100 + 100 mm for ISO/FEM 2	1330
Separate sideshifting 100 + 100 mm for ISO/FEM 3	1800
Separate sideshifter: 100 + 100 mm for ISO/FEM 4	2140
2 hydraulic functions – Independent arm control	640
2 hydraulic functions - Integrated sideshifting	630
Quick-release lower mountings, class 2 or class 3	605
Double max. pressure control valve	685
Frame bumper	260

Available on request

- Different arm dimensions
- Class 4 hooks
- Other opening ranges

Advantages

- Expertly manufactured
- Superior mechanical strength
- A secure grip around the load
- Reduced damage to loads

See this attachment in action



Technical data

Concrete block clamps

Model	Clamping						Hydraulic functions
	Operating pressure			Oil flow rate			
	Min.	Recommended	Max.	Min.	Recommended	Max.	
HC18 – HC22	80	160	180	15	25	45	1
HC26	80	160	180	15	25	45	1
HC30 – HC35	80	160	180	15	25	45	1
HCA18 – HCA22	80	160	180	15	25	45	1
HCA26	80	160	180	15	25	45	1
HCA30 – HCA35	80	160	180	15	25	45	1

Notes

A series of horizontal dotted lines for writing notes.



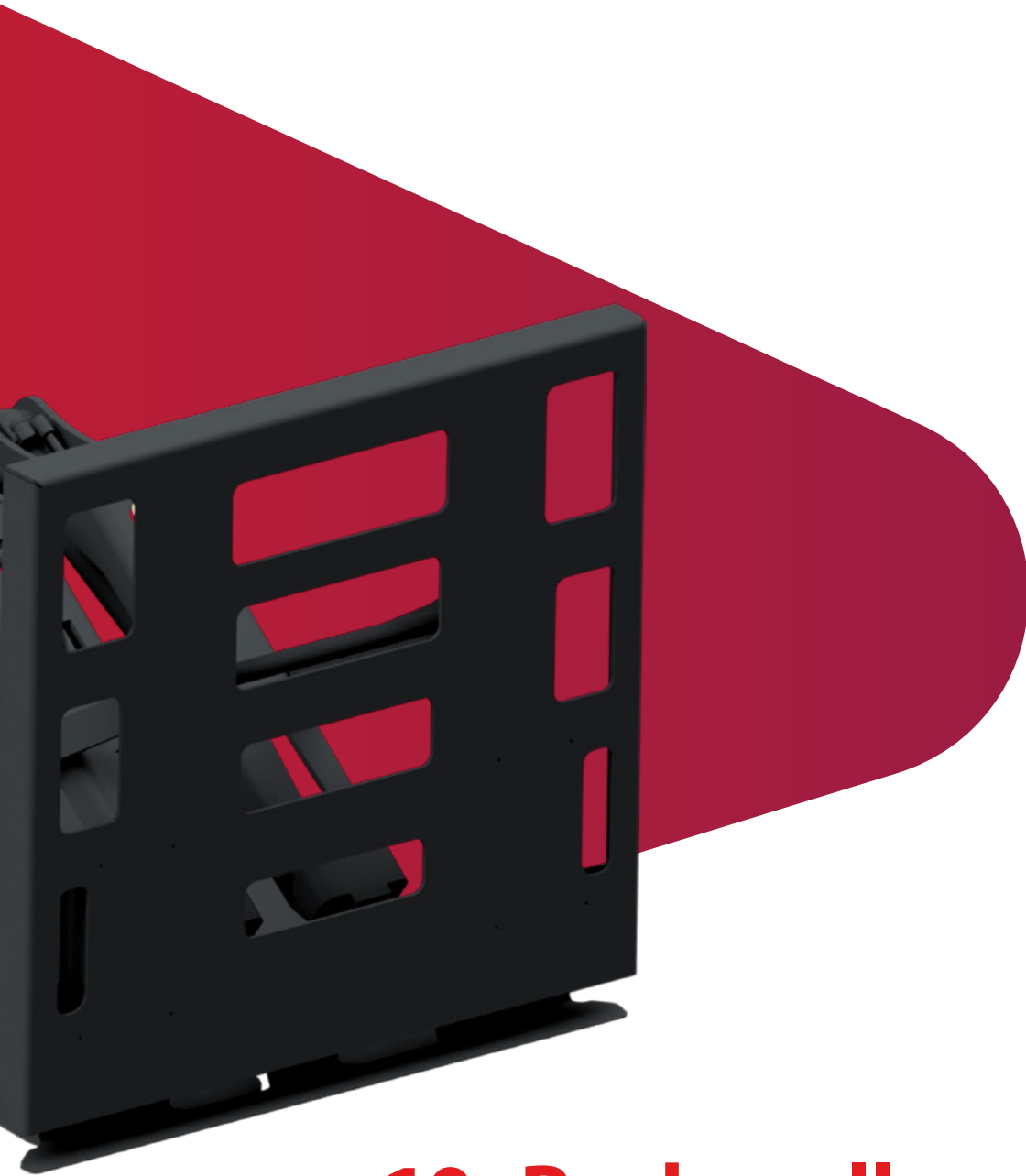

10. Push-pulls

Push-pulls allow goods to be handled using slip sheets instead of wooden pallets. Replacing pallets with inexpensive slip sheets maximises storage space, minimises maintenance costs and avoids damage to goods from old and worn pallets.

PP

1600 kg
2000 kg

Push-pull

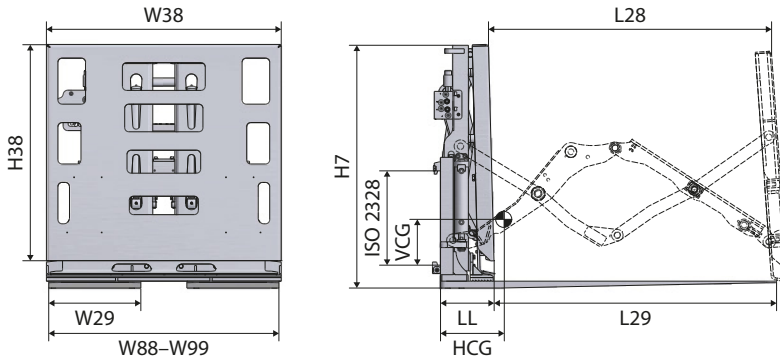

Product info

- Hook-on model
- Quick and easy installation
- Self-lubricating bushings
- High-strength steel plates
- With quick release hooks



Model	Capacity	W88-W99	W38	H38	L28	L29	W29	H7	LL	HCG	VCG	Weight	ISO 2328	RRP
	kg/mm													mm
Without sheet retainer														
PP1612	1600/600	860-1060	1000	940	1270	1220	380	1030	246	275	206	535	2A	13900
PP1612A	1600/600	1020-1220	1000	940	1270	1220	450	1030	246	290	190	563	2A	14180
PP2012	2000/600	860-1060	1000	940	1270	1220	380	1030	246	275	209	540	2A	14630
PP2012A	2000/600	1020-1220	1000	940	1270	1220	450	1030	246	292	190	573	2A	14920
With sheet retainer														
PP1612S	1600/600	860-1060	1000	940	1270	1220	380	1030	250	276	200	556	2A	19090
PP1612SA	1600/600	1020-1220	1000	940	1270	1220	450	1030	250	316	190	606	2A	19470
PP2012S	2000/600	860-1060	1000	940	1270	1220	380	1030	250	277	201	561	2A	19860
PP2012SA	2000/600	1020-1220	1000	940	1270	1220	450	1030	250	317	190	611	2A	20260

For model with sheet retainer please let us know your forklift voltage when placing your order.

Options

	RRP
	Euro
Reinforced bushings for dusty environments	On request
Different plates dimensions	On request
Different stroke	On request

Advantages

- Expertly manufactured
- Superior mechanical strength
- Time-saving
- Economical option
- Versatile attachment
- Easily mountable

Push-pull with separate sidehifter

PP.TS

1600 kg
2000 kg

Product info

- Hook-on model
- Quick and easy installation
- Self-lubricating bushings
- High-strength steel plates
- With quick release hooks
- With separate sidehifter 100 + 100 mm

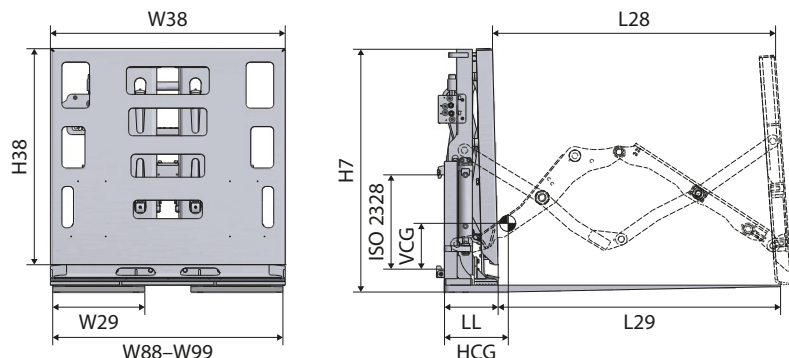

Model	Capacity	W88-W99	W38	H38	L28	L29	W29	H7	LL	HCG	VCG	Weight	ISO 2328	RRP
	kg/mm													mm
With sidehifter and without sheet retainer														
PP1612.TS	1600/600	860-1060	1000	940	1270	1220	380	1030	249	279	230	535	2A	14870
PP1612A.TS	1600/600	1020-1220	1000	940	1270	1220	450	1030	249	310	190	585	2A	15170
PP2012.TS	2000/600	860-1060	1000	940	1270	1220	380	1030	249	281	230	538	2A	15650
PP2012A.TS	2000/600	1020-1220	1000	940	1270	1220	450	1030	249	311	190	588	2A	15970
With sidehifter and with sheet retainer														
PP1612S.TS	1600/600	860-1060	1000	940	1270	1220	380	1030	269	299	200	585	2A	20430
PP1612SA.TS	1600/600	1020-1220	1000	940	1270	1220	450	1030	269	330	190	635	2A	20830
PP2012S.TS	2000/600	860-1060	1000	940	1270	1220	380	1030	269	282	201	588	2A	21250
PP2012SA.TS	2000/600	1020-1220	1000	940	1270	1220	450	1030	269	331	190	638	2A	21680

For model with sheet retainer please let us know your forklift voltage when placing your order.

Options

	RRP
	Euro
Reinforced bushings for dusty environments	On request
Different plates dimensions	On request
Different stroke	On request

Advantages

- Expertly manufactured
- Superior mechanical strength
- Time-saving
- Economical option
- Versatile attachment
- Easily mountable

See this attachment in action



PP-I

1600 kg
2000 kg

Push-pull fork-mounted

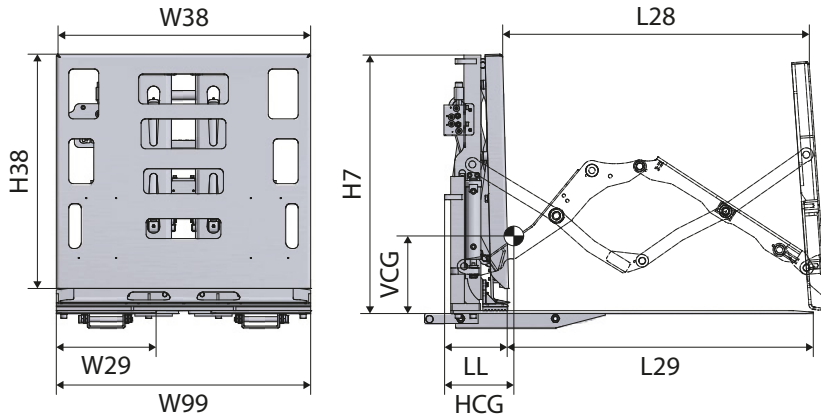

Product info

- Fork-mounted model
- Quick and easy installation
- Self-lubricating bushings
- High-strength steel plates



Model	Capacity	W88–W99	W38	H38	L28	L29	W29	H7	LL	HCG	VCG	Weight	RRP
	kg/mm											mm	mm
Without sheet retainer													
PP1612I	1600/600	860–1020	1020	940	1270	1220	400	1025	257	286	313	465	12050
PP1612IA	1600/600	1020–1220	1020	940	1270	1220	450	1025	257	288	313	485	12290
PP2012I	2000/600	860–1020	1020	940	1270	1220	400	1025	257	286	313	470	14060
PP2012IA	2000/600	1020–1220	1020	940	1270	1220	450	1025	257	288	313	490	14340
With sheet retainer													
PP1612IS	1600/600	860–1020	1020	940	1270	1220	400	1025	257	308	277	500	15900
PP1612ISA	1600/600	1020–1220	1020	940	1270	1120	450	1025	257	310	277	520	15780
PP2012IS	2000/600	860–1020	1020	940	1270	1220	400	1025	257	308	277	505	16400
PP2012ISA	2000/600	1020–1220	1020	940	1270	1220	450	1025	257	310	277	525	16520

For model with sheet retainer please let us know your forklift voltage when placing your order.

Available on request

- Slip-on for other fork sections
- Reinforced bushing for dusty environments
- Different stroke
- Different pushing plate dimensions

Load push

LP

1600 kg
2000 kg

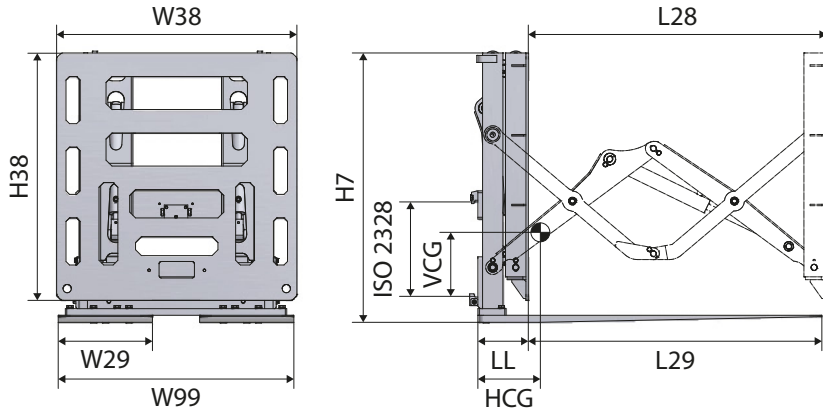

Product info

- Hook-on model
- Quick and easy installation
- Self-lubricating bushings
- High-strength steel plates



Model	Capacity	W99	W38	H38	L28	L29	W29	H7	LL	HCG	VCG	Weight	ISO 2328	RRP
	kg/mm													Euro
LP1612	1600/600	1000	1000	1050	1270	1220	400	1140	220	267	274	536	2A	11370
LP2012	2000/600	1000	1000	1050	1270	1220	400	1140	220	268	273	545	2A	12130

Options

	RRP
	Euro
Separate sideshifting 100 + 100 mm for ISO/FEM 2	1330
Reinforced bushing for dusty environments	On request
Different stroke	On request
Different pushing plate dimensions	On request

LP-I

1600 kg
2000 kg

Load push fork-mounted

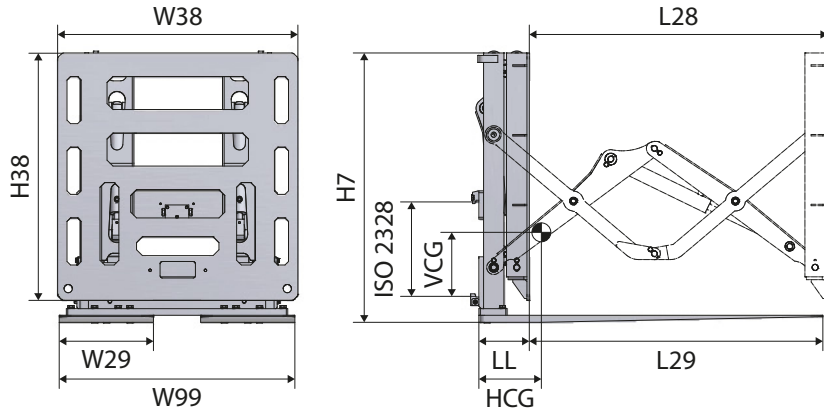

Product info

- Fork-mounted model
- Quick and easy installation
- Self-lubricating bushings
- High-strength steel plates



Model	Capacity	W99	W38	H38	L28	L29	W29	H7	LL	HCG	VCG	Weight	RRP
	kg/mm												
LP1612I	1600/600	1000	1000	1050	1270	1220	400	1140	210	282	292	495	11250
LP2012I	2000/600	1000	1000	1050	1270	1220	400	1140	210	274	284	520	12010

Available on request

- Reinforced bushing for dusty environments
- Different stroke
- Different pushing plate dimensions

Technical data

Push-pulls

Model	Positioning			Oil flow rate			Hydraulic functions
	Operating pressure			Oil flow rate			
	Min.	Recommended	Max.	Min.	Recommended	Max.	
PP	130	160	180	18	25	40	1
PP-I	130	160	180	18	25	40	1
LP	130	160	180	18	25	40	1
LP-I	130	160	180	18	25	40	1

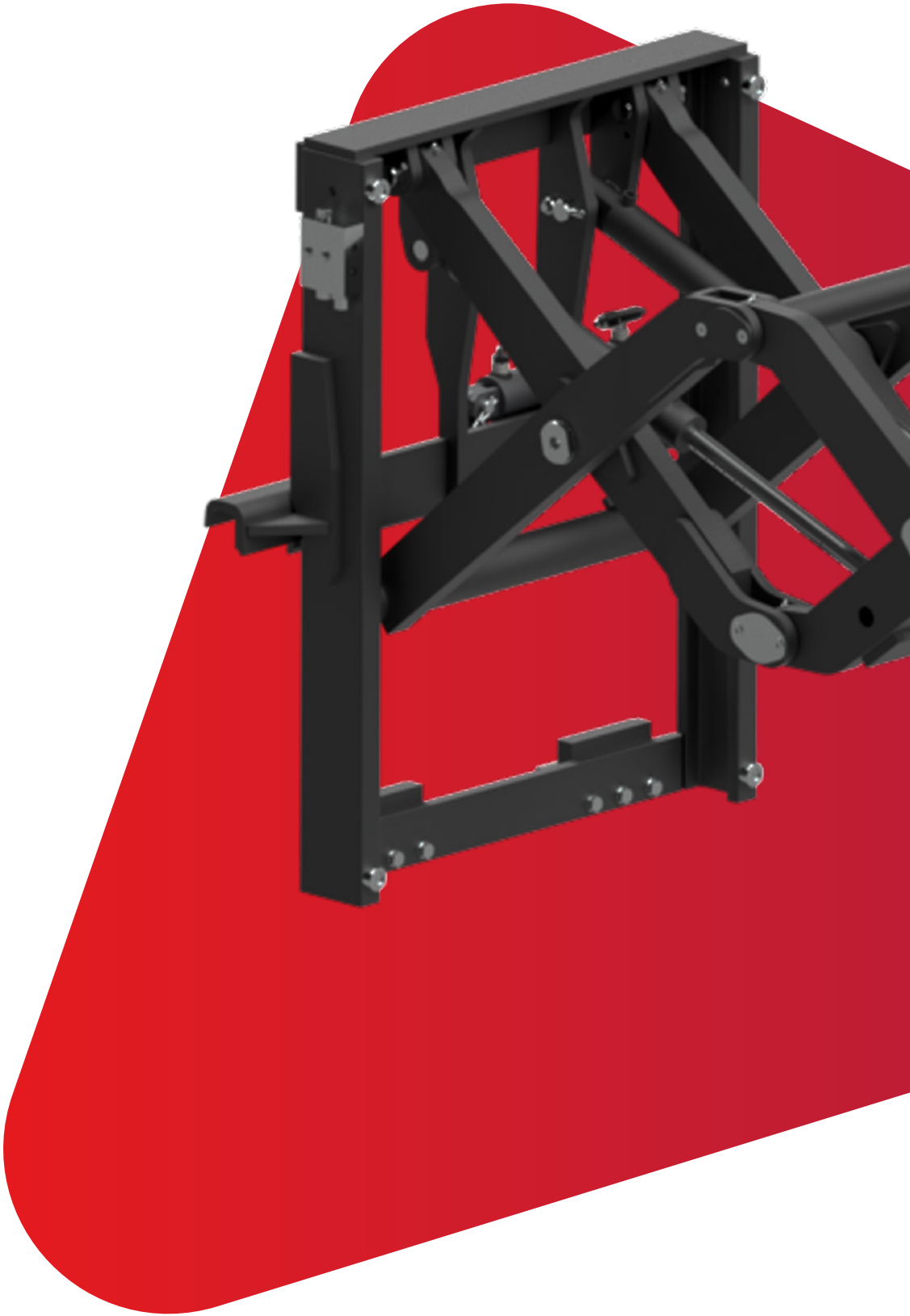



11. Load extenders

Do you need to place loads further than you can otherwise reach with your equipment?
Load extenders can help!

ES

3000 kg

Load extender

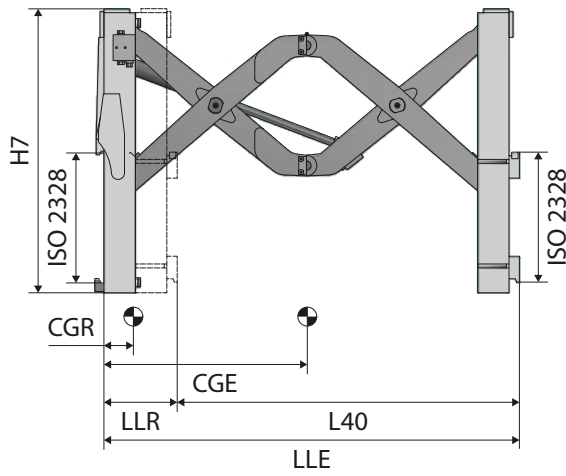

Product info

- Without forks
- ES1513T model with separate sideshift 100+100
- Ideal for unloading cargo onto vehicles from one side only



Model	Capacity retracted	Capacity extended	L40	H7	LLR	CGR	LLE	CGE	VCG	Weight	ISO 2328	RRP
	kg/mm	kg/mm	mm	mm	mm	mm	mm	mm	mm	kg		Euro
ES1513	3000/500	1500/500	1300	1030	310	150	1600	850	542	625	3A	16330
ES1513T	3000/500	1500/500	1300	1030	335	143	1600	795	527	655	3A	18180

Technical data

Load extender

Model	Clamping						Hydraulic functions
	Operating pressure			Oil flow rate			
	Min.	Recommended	Max.	Min.	Recommended	Max.	
ES	130	160	200	15	25	45	1



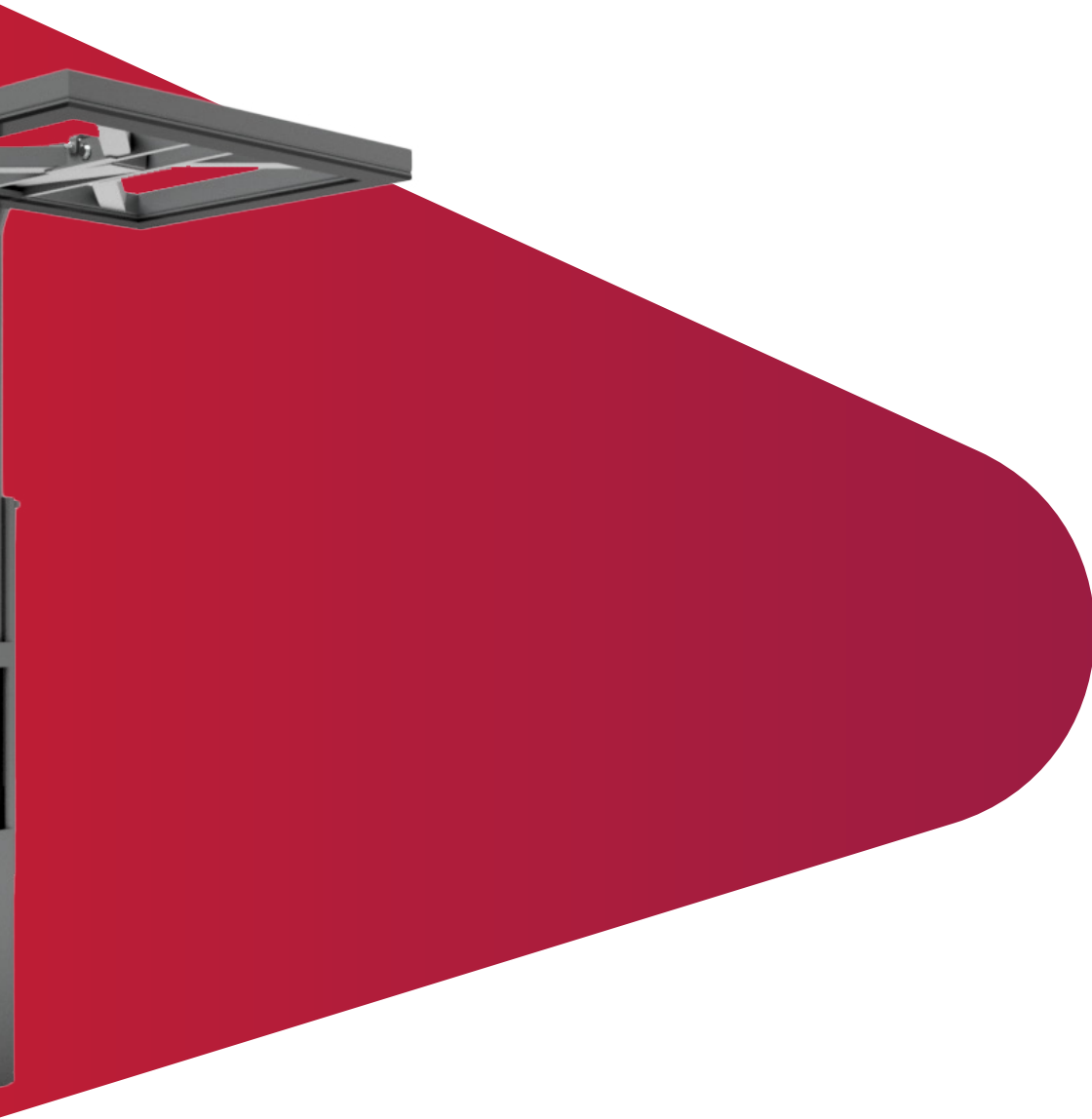

12. Load stabilisers

Handle unstable loads safely and efficiently with a load stabiliser!

SCA

1130 kg
1400 kg

Load stabiliser

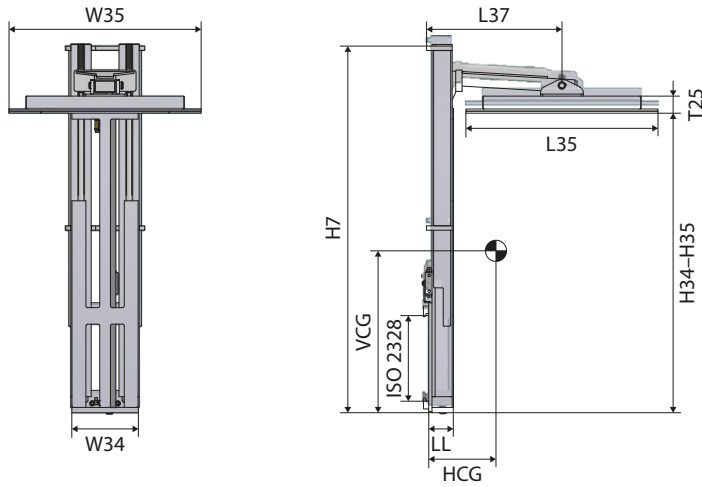

Product info

- Dimensions in relation to the floor
- Recommended for transporting unstable loads
- Recommended for transporting on uneven surfaces
- Sturdy oscillating platform
- Valve with load-tightening adjustment



Model	H34-H35	W34	L37	H7	L35 x W35 x T25	LL	HCG	VCG	Weight	ISO 2328	RRP
	mm	mm	mm	mm	mm	mm	mm	mm	kg		Euro
Standard model											
SCA100.0909	1130/2110	320	620	1430	900 x 900 x 65	96	225	787	237	2	5250
SCA100.0910	1130/2110	320	620	1430	900 x 1000 x 65	96	230	786	242	2	5370
SCA100.1010	1130/2110	320	670	1430	1000 x 1000 x 65	96	260	805	249	2	5460
SCA100.1012	1130/2110	320	670	1430	1000 x 1200 x 65	96	265	804	254	2	5520
SCA100.1212	1130/2110	320	770	1430	1200 x 1200 x 65	96	270	803	259	2	5590
SCA130.0909	1400/2650	320	620	1700	900 x 900 x 65	96	199	931	262	2	6110
SCA130.0910	1400/2650	320	620	1700	900 x 1000 x 65	96	204	930	266	2	6270
SCA130.1010	1400/2650	320	670	1700	1000 x 1000 x 65	96	234	949	273	2	6310
SCA130.1012	1400/2650	320	670	1700	1000 x 1200 x 65	96	239	948	278	2	6400
SCA130.1212	1400/2650	320	770	1700	1200 x 1200 x 65	96	244	947	283	2	6490

Advantages

- Expertly manufactured
- Superior mechanical strength
- Holds irregularly shaped goods in place
- Balances goods when driving on bumpy surfaces
- Very tough and durable
- Ideal for the food and beverage sector

Available on request

- Load backrest
- Special stroke and different contact plates

Load stabiliser

SCA

1130 kg
1400 kg

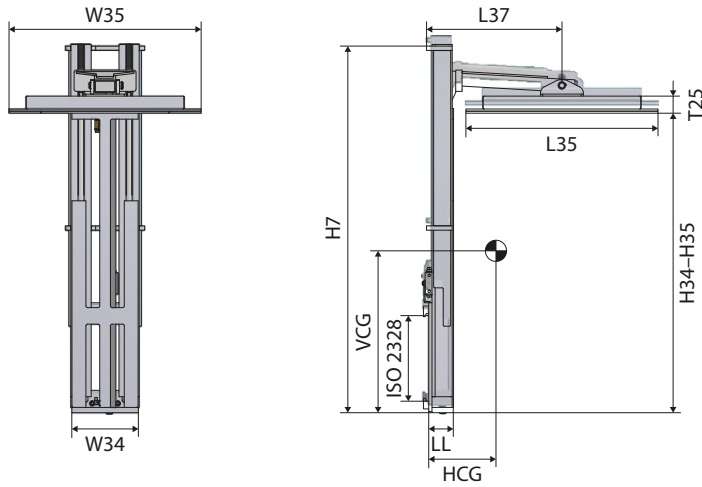

Product info

- Dimensions in relation to the floor



Model	H34-H35	W34	L37	H7	L35 x W35 x T25	LL	HCG	VCG	Weight	ISO 2328	RRP
	mm	mm	mm	mm	mm	mm	mm	mm	kg		Euro
Reinforced model											
SCA120.0909	1130/2110	320	620	1430	900 x 900 x 65	126	165	787	317	2	6810
SCA120.0910	1130/2110	320	620	1430	900 x 1000 x 65	126	170	786	322	2	7000
SCA120.1010	1130/2110	320	670	1430	1000 x 1000 x 65	126	200	805	329	2	7100
SCA120.1012	1130/2110	320	670	1430	1000 x 1200 x 65	126	205	804	334	2	7160
SCA120.1212	1130/2110	320	770	1430	1200 x 1200 x 65	126	210	803	339	2	7270
SCA150.0909	1400/2650	320	620	1700	900 x 900 x 65	126	139	931	342	2	7960
SCA150.0910	1400/2650	320	620	1700	900 x 1000 x 65	126	144	930	346	2	8130
SCA150.1010	1400/2650	320	670	1700	1000 x 1000 x 65	126	174	949	353	2	8210
SCA150.1012	1400/2650	320	670	1700	1000 x 1200 x 65	126	179	948	358	2	8330
SCA150.1212	1400/2650	320	770	1700	1200 x 1200 x 65	126	184	947	363	2	8410

Advantages

- Expertly manufactured
- Superior mechanical strength
- Holds irregularly shaped goods in place
- Balances goods when driving on bumpy surfaces
- Very tough and durable
- Ideal for the food and beverage sector

Available on request

- Load backrest
- Special stroke and different contact plates

Technical data

Load stabilisers

Model	Clamping						Hydraulic functions
	Operating pressure			Oil flow rate			
	Min.	Recommended	Max.	Min.	Recommended	Max.	
SCA	130	160	200	12	15	40	1

Notes

A series of horizontal dotted lines for writing notes.



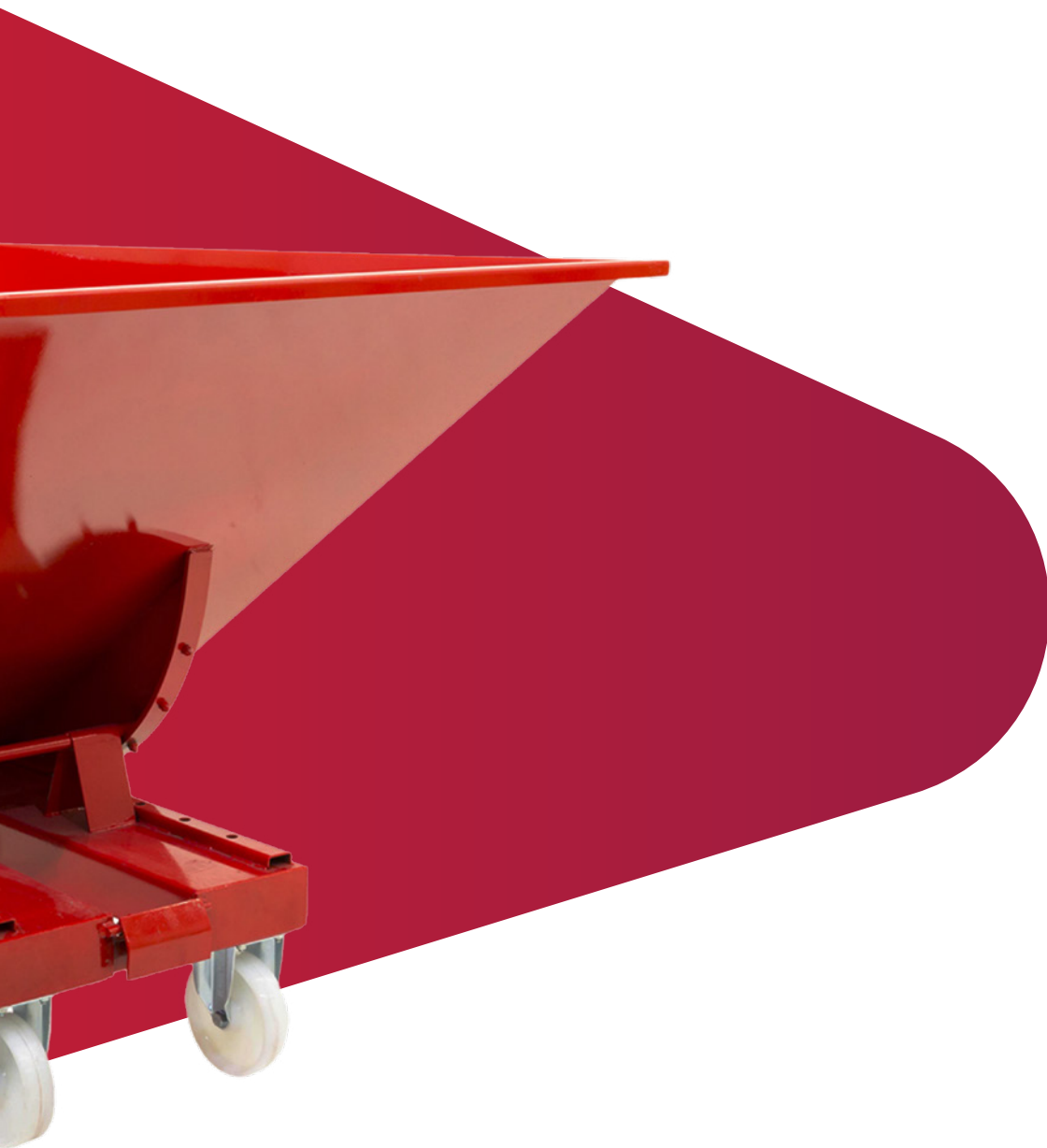

13. Skips

Tipping skips are the perfect solution for simplifying waste sorting processes. We have two types in our range: roll-forward skips and bottom-emptying skips. Roll-forward skips should be strategically placed throughout the workplace to keep it free of scrap and waste. Bottom-emptying skips have a base that opens and closes, allowing waste to be dumped easily and safely.

KPC

1500 kg
2000 kg

Roll-forward skip



Product info

- Automatic tipping system for more efficiency
- Securely attached to the carriage with a safety chain
- Optional rubber or nylon castors
- Reinforced fork sleeves
- Reinforced corners for increased strength and rigidity
- European quality



Model	Volume	Capacity	Height	Width	Length	Max. fork section	Min. distance between forks	Weight	Castors	RRP
	l	kg	mm	mm	mm	mm	mm	kg		Euro
Powder coated										
★ CB92796	320	1500	750	840	1235	230 x 100	160	80	No	690
CB92806	320	1500	750	840	1235	230 x 100	160	80	Nylon	880
CB92818	320	1500	750	840	1235	230 x 100	160	80	Rubber	850
★ CB92798	520	2000	870	865	1525	230 x 100	160	101	No	880
CB92808	520	2000	870	865	1525	230 x 100	160	101	Nylon	980
CB92820	520	2000	870	865	1525	230 x 100	160	101	Rubber	910
★ CB92008	765	2000	870	1215	1525	230 x 100	160	122	No	1010
CB92810	765	2000	870	1215	1525	230 x 100	160	122	Nylon	1120
CB92822	765	2000	870	1215	1525	230 x 100	160	122	Rubber	1230
★ CB92800	1030	2000	1045	1215	1700	230 x 100	160	157	No	1300
CB92812	1030	2000	1045	1215	1700	230 x 100	160	157	Nylon	1580
CB92824	1030	2000	1045	1215	1700	230 x 100	160	157	Rubber	1550
★ CB92802	1340	2000	1248	1066	2073	230 x 100	160	205	No	1540
CB92814	1340	2000	1248	1066	2073	230 x 100	160	205	Nylon	1630
CB92826	1340	2000	1248	1066	2073	230 x 100	160	205	Rubber	1700
★ CB92804	1700	2000	1248	1316	2073	230 x 100	560	253	No	1970
CB92816	1700	2000	1248	1316	2073	230 x 100	560	253	Nylon	1930
CB92828	1700	2000	1248	1316	2073	230 x 100	560	253	Rubber	2010

★ Suggested selection

Roll-forward skip

KPC

1500 kg



Product info

- Automatic tipping system for more efficiency
- Securely attached to the carriage with a safety chain
- Optional rubber or nylon castors
- Reinforced fork sleeves
- Reinforced corners for increased strength and rigidity
- European quality



Model	Volume	Capacity	Height	Width	Length	Max. fork section	Min. distance between forks	Weight	Castors	RRP
	l	kg	mm	mm	mm	mm	mm	kg		Euro
Stainless steel										
BH30526	600	1500	870	855	1525	230 x 95	160	111	No	1720
BH30528	600	1500	870	855	1525	230 x 95	160	111	Nylon	1920
BH30530	600	1500	870	855	1525	230 x 95	160	111	Rubber	1870
BH30532	900	1500	870	1215	1525	230 x 95	160	128	No	1790
BH30534	900	1500	870	1215	1525	230 x 95	160	128	Nylon	1880
BH30536	900	1500	870	1215	1525	230 x 95	160	128	Rubber	2030

See this attachment in action



Powder-coated



Stainless steel



BES

1730 kg
1780 kg

Bottom-emptying skip



Model	Volume	Capacity	Height	Width	Length	Max. fork section	Min. distance between forks	Weight	RRP
	l	kg/mm	mm	mm	mm	mm	mm	kg	Euro
BA52682	750	1730	600	1500	875	220 x 70	630	230	1960
BA52684	1000	1750	750	1500	875	220 x 70	630	250	2200
BD83876	1300	1780	1000	1500	875	160 x 70	630	280	2330

See this attachment in action



Notes

A series of horizontal dotted lines for writing notes.



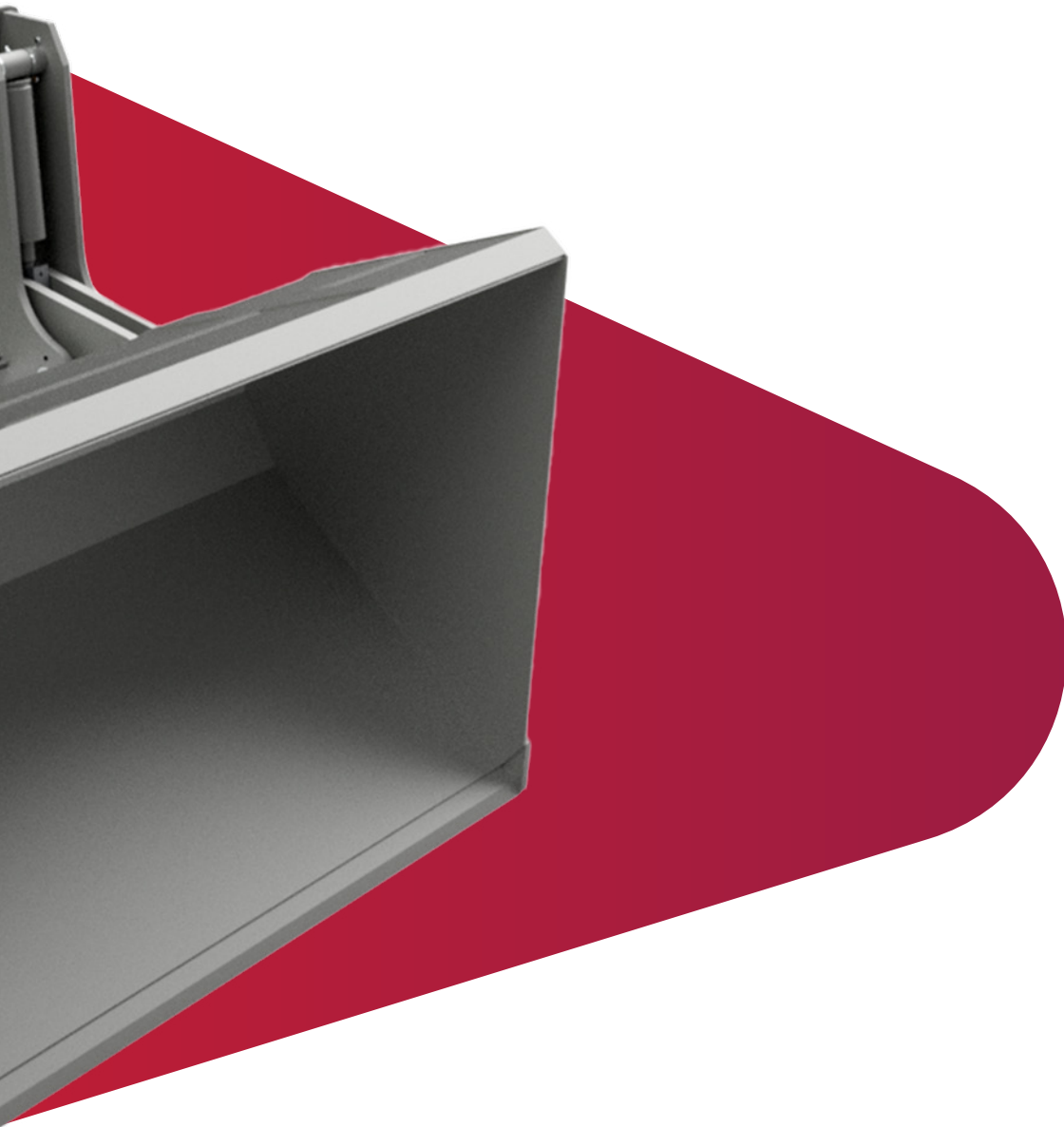

14. Scoops

A scoop converts forklifts and other equipment into a mobile shovel, allowing you to easily load and tip bulk materials such as sand, gravel, coal, etc.

B**800 kg
2500 kg**

Hydraulic scoop

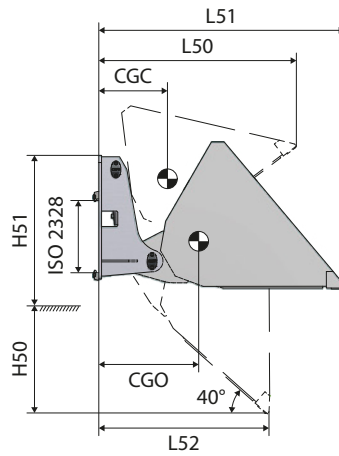
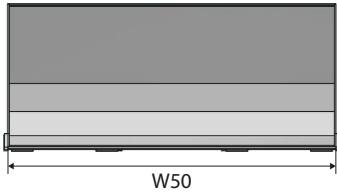

Product info

- Hook-on model
- Double cylinder-operated



Model	Volume	Capacity	Tilt	W50	H50/H51	L50	L51	L52	CGC	CGO	Weight	ISO 2328	RRP
	l	kg/mm	° (±)	mm	mm	mm	mm	mm	mm	mm	kg		Euro
B30	310	800/500	40/40	900	560	1224	1124	925	297	341	378	2	6280
B50	490	1200/500	40/40	1400	560	1224	1115	930	325	375	424	2	6940
B60	560	1400/500	40/40	1600	560	1225	1100	955	326	390	440	2	7470
B80	810	2000/500	40/40	1800	650	1345	1180	985	360	440	548	2	8470
B100	1000	2500/500	40/40	2350	650	1345	1180	985	405	580	600	3	9650

Advantages

- Expertly manufactured
- Superior mechanical strength

Hydraulic scoop – fork-mounted

HS



Product info

- Fork-mounted model
- Secured with a chain
- Single cylinder



Model	Volume	Height	Width	Length	Max. fork section	Min. distance between forks	Weight	RRP
	l	mm	mm	mm	mm	mm	kg	Euro
★ BH24466	950	772	1640	1394	185 x 70	660	300	3380
BH24468	1100	772	1840	1394	185 x 70	660	360	3500

★ Suggested selection

MS

800 kg
2500 kg

Mechanical scoop – fork mounted

Product info

- Fork-mounted model



Model	Volume	Height	Width	Length	Max. fork section	Min. distance between forks	Weight	RRP
	l	mm	mm	mm	mm	mm	kg	Euro
CC04310	500	580	860	1873	170 x 60	351	230	1860
★ BH22332	600	606	965	1873	170 x 60	466	250	1860
BH22608	800	606	1400	1873	170 x 60	466	280	2090
BH22334	1000	606	1710	1873	170 x 60	466	310	2220
BH22336	1200	606	1910	1873	170 x 60	466	331	2350

★ Suggested selection

Notes

A series of horizontal dotted lines for writing notes.





15. Booms

A boom allows you to handle products in rolls or coils. Our range includes coil booms and carpet poles.

SP

Coil boom

1000 kg
6500 kg

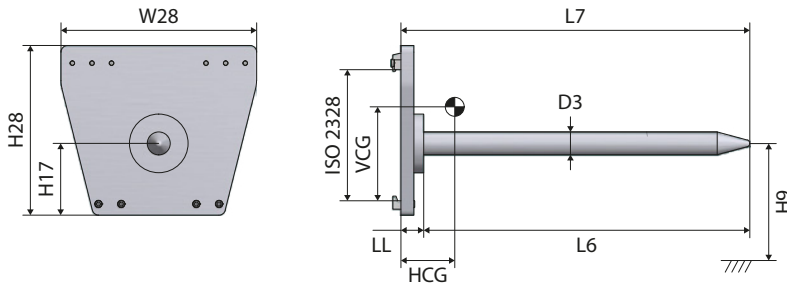

Model	Capacity	L6	D3	L7	H17	H28 x W28	H9	LL	HCG	VCG	Weight	ISO 2328	RRP
	kg/mm												mm
SP1010	1000/500	1000	70	1070	230	520 x 600	250	70	141	220	127	2A	1700
SP1510	1500/500	1000	80	1070	230	520 x 600	250	70	154	220	153	2A	1890
SP1515	1500/500	1500	80	1570	220	520 x 600	250	70	283	216	173	2A	2150
SP2515	2500/500	1500	90	1570	230	520 x 600	250	70	320	206	185	2A	2490
SP2520	2500/500	2000	90	2070	230	520 x 600	250	70	490	202	215	2A	2820
SP3515	3500/500	1500	100	1590	280	620 x 700	300	90	280	262	275	3A	3050
SP3520	3500/500	2000	100	2090	280	620 x 700	300	90	275	260	298	3A	3380
SP4518	4500/500	1800	120	1890	280	620 x 700	300	90	414	254	377	3A	3690
SP4525	4500/500	2500	120	2590	300	620 x 700	300	90	664	250	440	3A	4120
SP6520	6500/800	2000	150	2090	370	740 x 800	450	90	527	351	555	4A	4780
SP6525	6500/800	2500	150	2590	370	740 x 800	450	90	722	348	625	4A	5630

Advantages

- Easy to attach
- Expertly manufactured
- Superior mechanical strength
- Ideal for the industrial sector
- Ideal for paper handling

Available on request

- Different lengths and diameters



Carpet pole

AT
550 kg

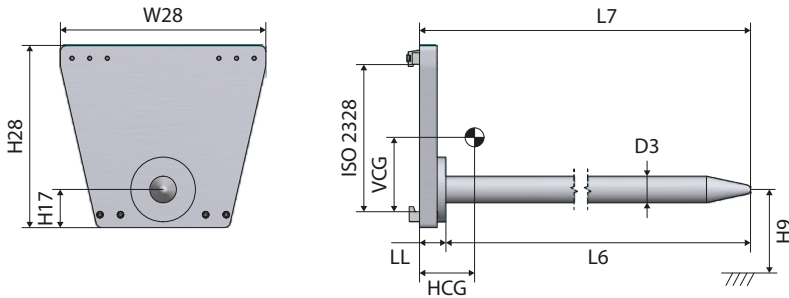

Model	Capacity	L6	D3	L7	H17	H28 x W28	H9	LL	HCG	VCG	Weight	ISO 2328	RRP
	kg/mm												Euro
AT28A	550/1800	2800	70	2870	160	520 x 600	200	70	685	177	180	2A	4320
AT38	550/2300	3800	75	3870	180	520 x 600	200	70	1030	152	195	2A	4680

Available on request

- Different lengths and diameters





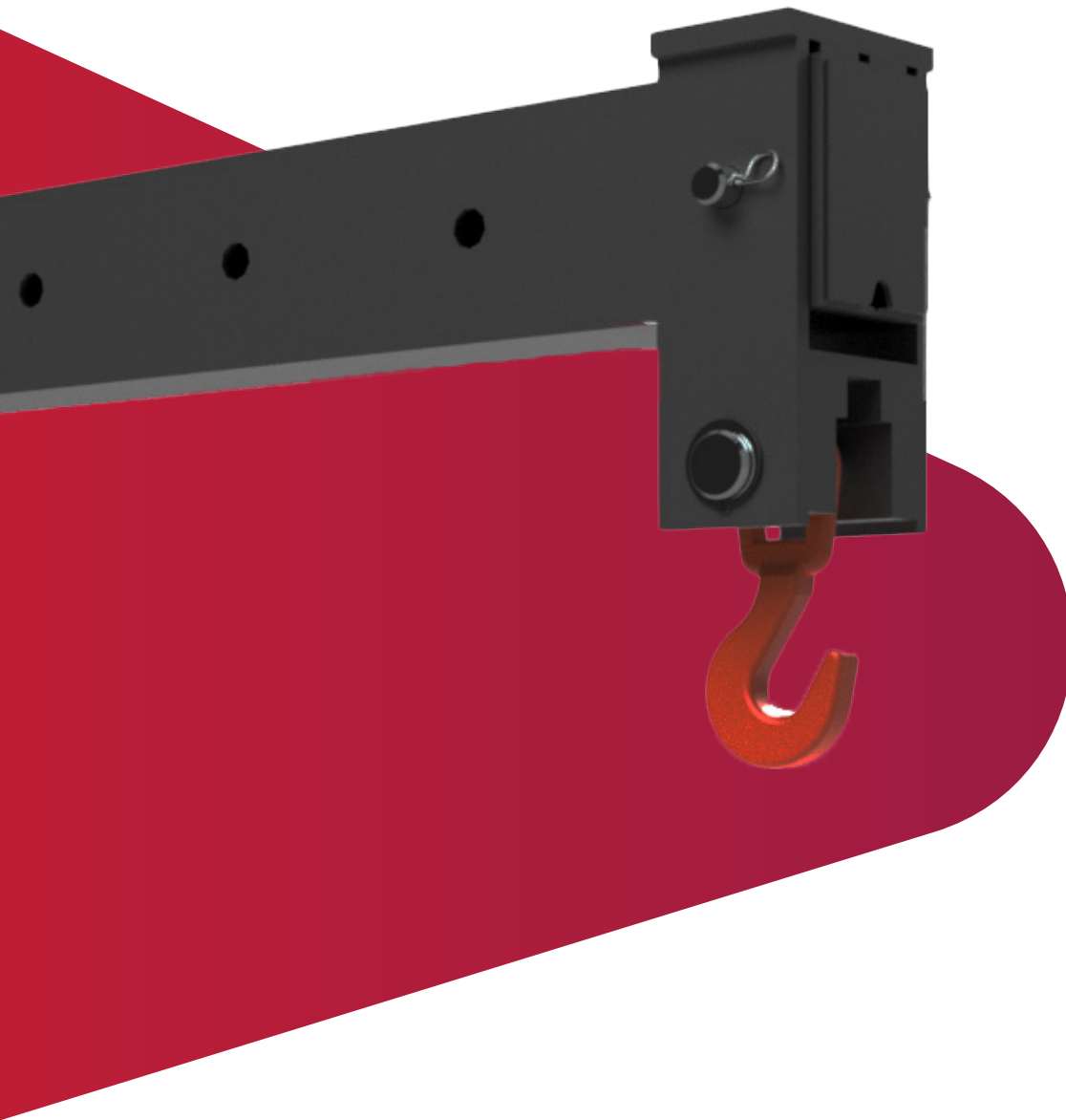

16. Crane jibs

A crane jib allows you to lift loads that are unconventional in shape and/or size or unsuitable for pallets. Several lifting positions can be used along the crane arm. We offer two models depending on the type of mounting required: fork-mounted crane jibs and carriage-mounted crane jibs. Both are fully tested and CE-certified.

GAB**1000 kg
7000 kg**

Carriage-mounted crane jib

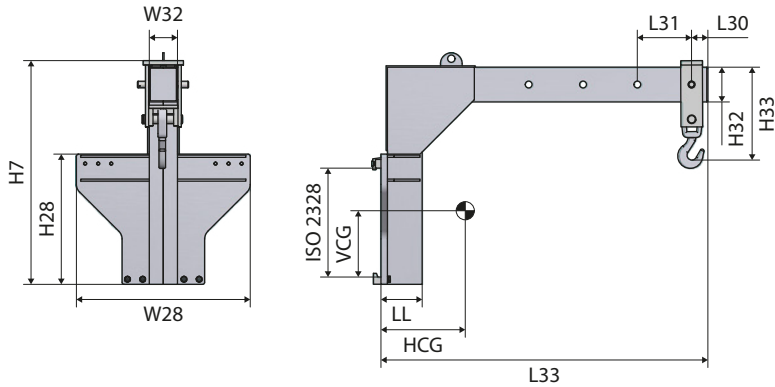

Model	Capacity	H7	L33	H32	W32	L30	L31	H33	W28 x H28	LL	HCG	VCG	Weight	ISO 2328	RRP
	kg/mm														mm
GAB1T	1000/500	1000	1000	100	100	60	130	245	600 x 500	115	260	534	95	2	2690
GAB2T	2000/500	1000	1000	140	120	60	150	490	600 x 500	160	258	545	136	2	2970
GAB3T	3000/500	1000	1500	160	130	70	250	350	800 x 600	190	358	567	226	3	3500
GAB4T	4000/500	1000	2000	180	140	70	250	450	800 x 600	210	559	589	260	3	4440
GAB6T	6000/500	1200	2000	240	170	100	250	470	800 x 735	280	558	723	443	4	6530
GAB7T	7000/600	1900	2900	240	170	100	250	590	800 x 735	280	735	607	600	4	8190

Available on request

- Different dimensions and capacities
- Crane with a manual or hydraulic positioning system
- Fork-mounted crane jib attachments

Fork-mounted crane jib manual

GAB1

Product info

- L2 – Maximum arm length
- W11 – Maximum fork spread measured across forks

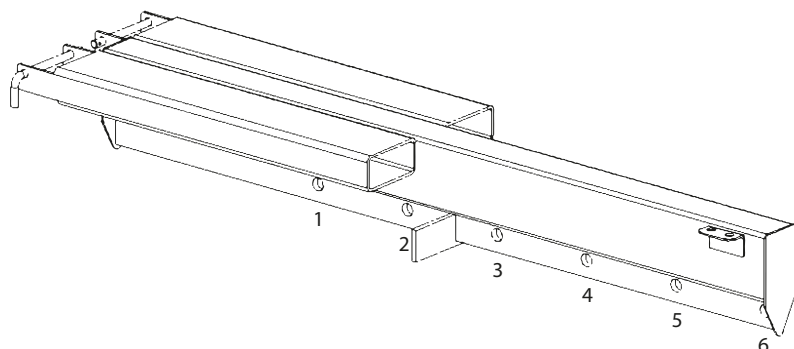

Model	L2	W11	Fits max. fork section	CG	Weight	RRP
	mm	mm	mm	mm	kg	Euro
BA52814	1750	450	135 x 60	675	94	1160
★ BA52818	1750	450	155 x 60	757	100	1240

★ Suggested selection

Position of the safety lifting hook

Position	Fixed arm					
	1	2	3	4	5	6
BA52814						
Capacity (kg)	2000	1800	1600	1200	900	600
Load centre (mm)	500	750	1000	1250	1500	1750
BA52818						
Capacity (kg)	4000	3800	3200	2500	1900	1100
Load centre (mm)	500	750	1000	1250	1500	1750

GAB2

Fork-mounted crane jib manual telescopic

Product info

- L2 – Maximum arm length
- W11 – Maximum fork spread measured across forks

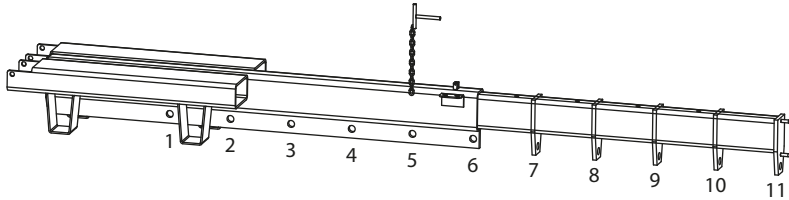

Model	L2	W11	Fits max. fork section	CG	Weight	RRP
	mm	mm	mm	mm	kg	Euro
BA52820	3000	450	150 x 65	675	151	1660
★ BA52824	3000	450	150 x 65	757	156	2050

★ Suggested selection

Position of the safety lifting hook

Position	Extendable arm										
	1	2	3	4	5	6	7	8	9	10	11
BA52820											
Capacity (kg)	2000	1800	1600	1200	900	600	500	400	350	280	200
Load centre (mm)	500	750	1000	1250	1500	1750	2000	2250	2500	2750	3000
BA52824											
Capacity (kg)	4000	3800	3200	2500	1900	1100	975	850	650	500	400
Load centre (mm)	500	750	1000	1250	1500	1750	2000	2250	2500	2750	3000

Fork-mounted crane jib manual telescopic, adjustable

GAB3

2500 kg
5000 kg

Product info

- W11 – Maximum fork spread measured across forks

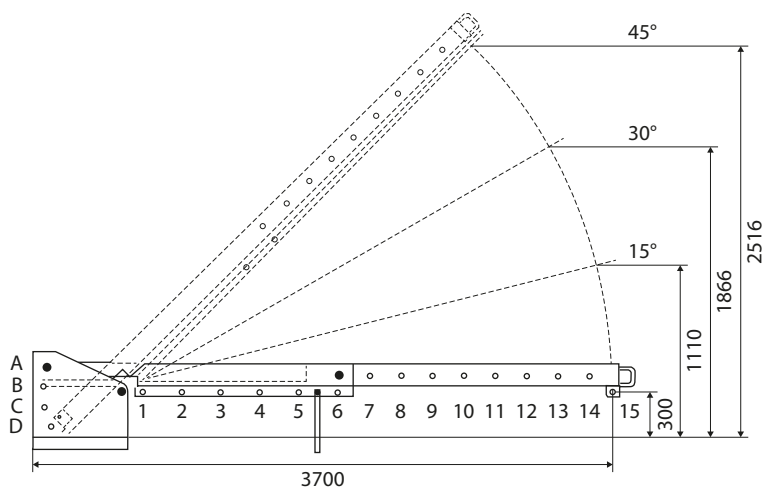

Model	Capacity/700 mm	Min. fork length	W11	Fits max. fork section	Weight	RRP
	kg	mm	mm	mm	kg	Euro
★ BA52846	2500	800	549	180 x 60	218	2740
★ BA52848	5000	800	574	180 x 70	250	3090

★ Suggested selection

Position of the safety lifting hook

Position	Fixed arm						Extendable arm									
	1	2	3	4	5	6	7	8	9	10	11	12	13	14	15	
BA52846 – capacity 2500 kg																
Capacity (kg)	2500	2500	2500	1800	1400	1200	1050	950	850	770	700	650	600	560	500	
Load centre (mm)	700	950	1200	1450	1700	1950	2100	2300	2500	2700	2900	3100	3300	3500	3700	
BA52848 – capacity 5000 kg																
Capacity (kg)	5000	3550	2750	2250	1950	1700	1550	1400	1300	1200	1150	1050	1000	950	900	
Load centre (mm)	700	950	1200	1450	1700	1950	2100	2300	2500	2700	2900	3100	3300	3500	3700	





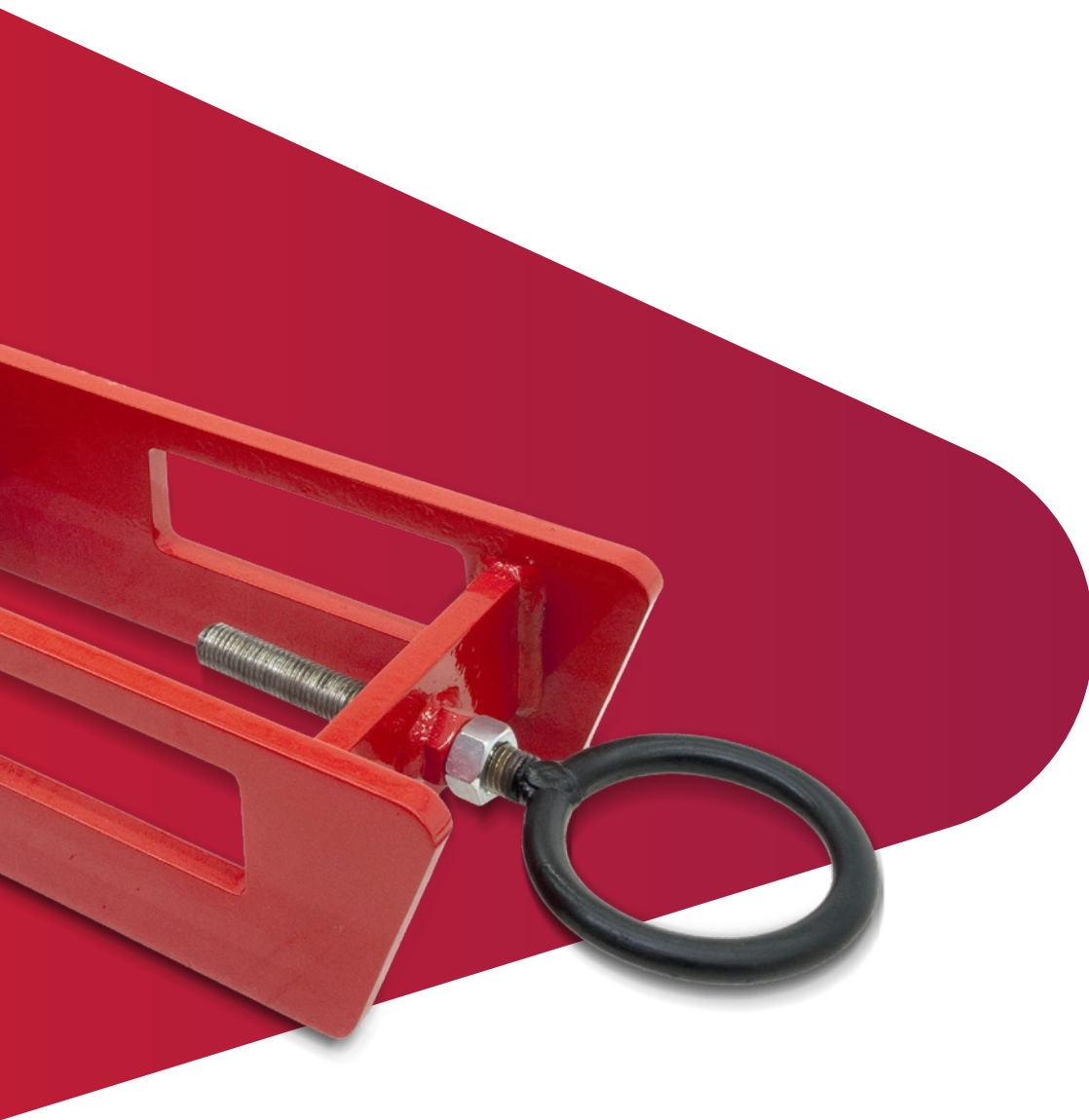

17. Fork-mounted lifting hook

A fork-mounted lifting hook or jib allows you to lift loads from above, which is particularly useful when the forks won't fit under the load. The attachment is suitable for forklifts, telehandlers, skid steer loaders, tractor loaders and other equipment used in construction and agricultural environments. All fork-mounted lifting in our range are fully tested and CE-certified.

FMH

2500 kg
5000 kg

Fork-mounted lifting hook



Model	Capacity	Height	Width	Length	Max. fork section	Min. distance between forks	Weight	RRP
	kg	mm	mm	mm	mm	mm	kg	Euro
★ BA52850	2500	130	785	180	150 x 50	300	27	610
BA52854	4000	130	785	180	150 x 50	300	27	740
BA52856	5000	130	785	180	150 x 50	300	30	860

★ Suggested selection



Fork-mounted shunting aid

SHA



Product info

- Stable entry sleeves for fork tines
- With slip guard
- Easy hitching
- Type RH: with coupling ball
- Type RH-RM: with trailer coupling (Rockinger RO 805 B with bolts \varnothing 31,5 mm)
- Type RH-RMK, RM (also with coupling ball)

REF [CC65332](#)



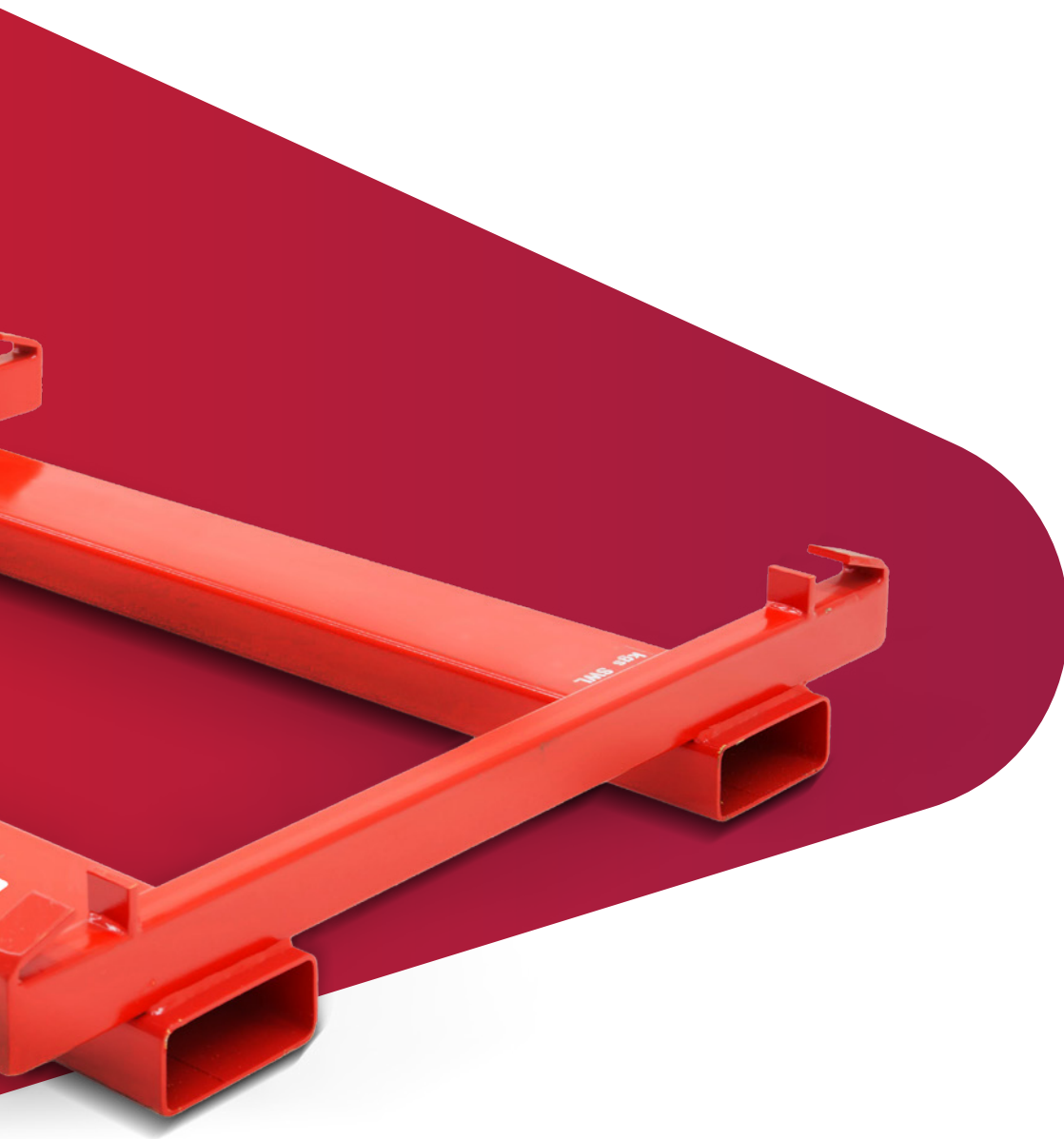

18. Big-bag handlers

This is the easy way to handle big bags! Simply add the big-bag handler to a machine, and you're ready to go.

BBH

1000 kg
1500 kg

Fork-mounted big-bag handler



Model	Capacity	Max. fork section	Max. fork spread (over the forks)	Distance between claws	Weight	RRP
	kg	mm	mm	mm	kg	Euro
CA99534	1000	140 x 50	755	1000 x 1000	97	On request
★ CA99532	1500	140 x 50	755	1000 x 1000	97	540

★ Suggested selection
Fully tested and CE-certified



Notes

A series of horizontal dotted lines for writing notes.



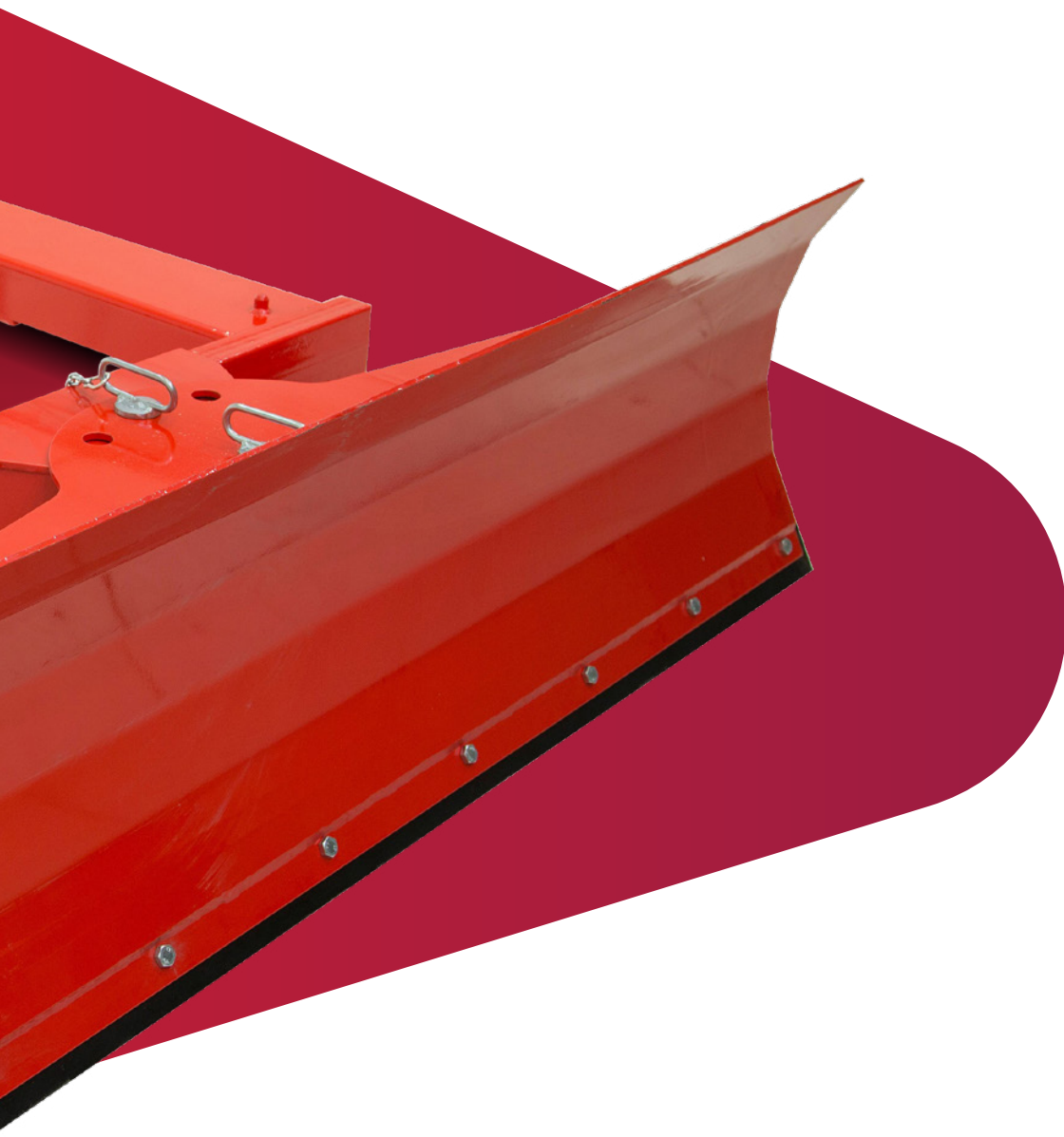

19. Snow ploughs

Do you occasionally have to clear snow? A snow plough is the perfect attachment to keep businesses going through the winter. Its concave design prevents snow from building up and immobilising or damaging the machine. Plus, this attachment can also be used for yard clean-up during the summer months!



Model	Blade width	Blade height	Rubber thickness	Max. fork section	Min. distance between forks	Weight	RRP
	mm	mm	mm	mm	mm	kg	Euro
With rubber strip							
BG05586*	1800	500	30	190 x 70	620	160	1200
B148204	1500	500	30	190 x 70	620	157	1570
★ BH22338	1800	500	30	190 x 70	620	180	1610
BH93846	2000	500	30	190 x 70	620	214	1660
BH93848	2400	500	30	190 x 70	620	239	1500
With spring loaded blade							
★ BH35814	1800	730	–	190 x 70	415	185	2420
BH30454	2100	730	–	190 x 70	415	231	2560
BH39926	2400	730	–	190 x 70	415	289	2740

★ Suggested selection

* Fixed blade

See this attachment in action



Notes

A series of horizontal dotted lines for writing notes.





20. Yard scrapers

Push bulk materials such as sand, snow or coal to a point where they can be easily picked up with a yard scraper. This attachment can also be used to clear yards or floors.

YSC

Yard scraper



Model	Blade width	Blade height	Rubber thickness	Max. fork section	Min. distance between forks	Weight	RRP
	mm	mm	mm	mm	mm	kg	Euro
★ BG91882	2000	400	35	150 x 50	605	90	1590
★ BG91884	2650	400	35	150 x 50	605	130	1690

★ Suggested selection

Notes

A series of horizontal dotted lines for writing notes.





21. Fork-mounted drum handlers and drum tippers

Fork-mounted drum clamps and drum tippers are the most affordable solution for transporting and rotating drums. With no hydraulic or electrical connections required, they are easy to install.

DC

500 kg
1000 kg

Fork-mounted drum handler



[BG11320](#)



[BG15622](#)



[BG52752](#)



Model	Capacity	Max. fork section	Min. distance between forks	Number of drums	Drum type	Weight	RRP
	kg					mm	kg
★ BG11320	500	140 x 50	280	1	Steel, plastic L-ring and XL-ring	62	1330
★ BG15622	750	140 x 50	280	1	Steel, plastic L-ring and XL-ring	75	1490
BG52752	1000	160 x 65	490	2	Steel, plastic L-ring and XL-ring	79	2030

★ Suggested selection



Fork-mounted mechanical drum tipper

DR
360 kg

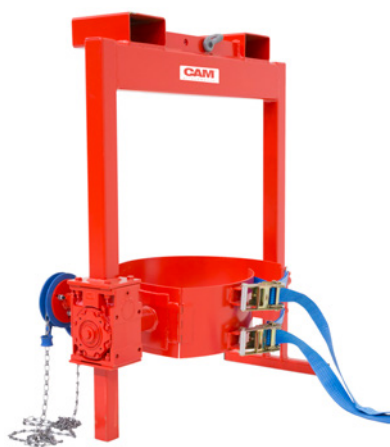

[BG19328](#)

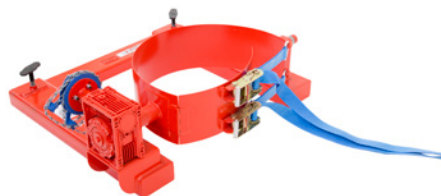

[BG19622](#)

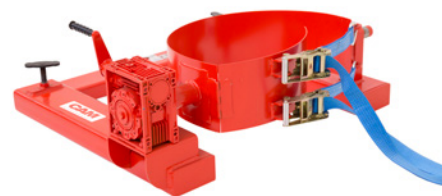

[BG19322](#)



Model	Capacity	Max. fork section	Min. distance between forks	Total width	Number of drums	Drum type	Type of operation	Weight	RRP
	kg	mm	mm	mm				kg	Euro
BG19328	360	140 x 50	425	707	1	210 l steel	Looped chain	94	3060
BG19622	360	140 x 50	660	942	1	210 l steel	Looped chain	96	2880
BG19322	360	140 x 50	660	942	1	210 l steel	Crank handle	90	2550

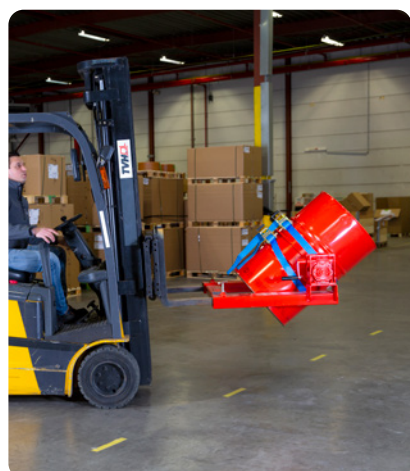





22. Forklift cages

Stay safe when working at height with a forklift cage! This attachment comes with a toolbox, so you can keep tools close at hand when you need them. Our range also includes a model fitted with nylon wheels, which allow you to quickly and efficiently store the cage after use.

SKG

300 kg

Forklift cage

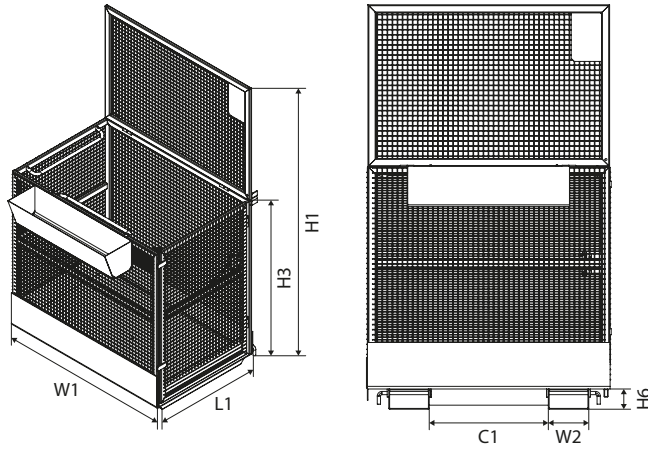

Product info

- Capacity: 2 people
- The rear side folds down to 1,120 mm
- Safely attached to the forklift with locking pins behind the fork heels



Model	Capacity	Max. height 1	Cage L1 x W1 x H3	Colour	Fits max. fork section W2 x H6	Min. distance between forks C1	Weight	RRP
	kg	mm	mm		mm	mm	kg	Euro
Without wheels								
★ CC30908	300	2000	885 x 1211 x 1190	Orange	190 x 90	589	155	1320
CC30910	300	2000	885 x 1211 x 1190	Red	190 x 90	589	155	1360
With nylon wheels								
CC30912	300	2000	885 x 1211 x 1190	Orange	190 x 90	589	155	1810
CC30914	300	2000	885 x 1211 x 1190	Red	190 x 90	589	155	1810
★ Suggested selection								

Notes

A series of horizontal dotted lines for writing notes.





23. Forks & fork extensions

Our wide range includes all the forks you need, whatever the size, type or configuration: FEM forks, reach forks, weighing forks, fork extensions and more.

Guide

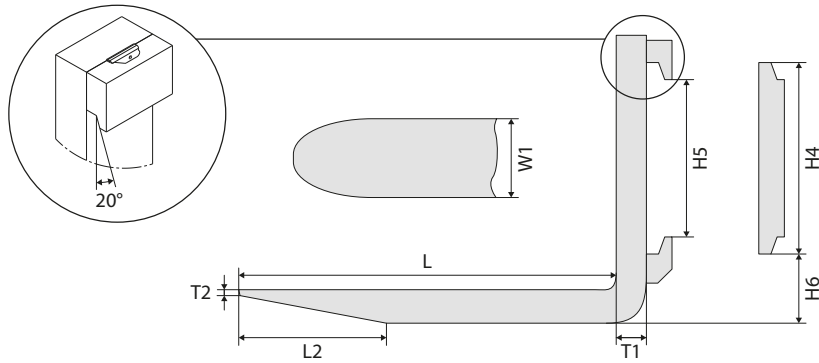

Product info

- All FEM forks meet ISO standards
- High-quality chromium-manganese steel to ensure high mechanical strength
- Refined finish, manufactured from a rolled profile
- All forks comply with European standards



Class FEM	Forklift capacity	Norm ISO 2328	H6	H4	H5	We propose to use fork section = W1 x T1
	kg		mm	mm	mm	mm
1	0-999	1A 1B	76 114	331	306	80 x 35
2	1000-1500	2A 2B	76 152	407	382	80 x 40 100 x 32 100 x 35 100 x 40
	1800-2000	2A 2B	76 152			100 x 40 100 x 45 120 x 40
	2200-2500	2A 2B	76 152			100 x 45 125 x 40
3	2800-3500	3A 3B	76 203	508	477	100 x 45 100 x 50 125 x 45
		3A 3B	76 203			125 x 45 125 x 50 130 x 60
	3500-4999	3A 3B	76 203			125 x 45 125 x 50 130 x 60
4	5000-9000	4A 4B	127 254	635	598	150 x 50 130 x 60 150 x 60 150 x 70

Fork section W1 x T1	Capacity/pair	ISO 2328	Fork length L1															
			800 mm	900 mm	1000 mm	1070 mm	1100 mm	1150 mm	1200 mm	1300 mm	1400 mm	1500 mm	1600 mm	1800 mm	2000 mm	2200 mm	2400 mm	2500 mm
80 x 40	2000/500	2A	BF38622	BF38628	BE44706	-	BF38670	BF38694	BE44710	B005664	BF38762	BF38790	BF38826	BF38860	-	-	-	-
100 x 35	1900/500	2A	B004664	BF38630	BF38642	BF29396	BF38672	BF38696	BF38712	BF38744	BF38764	BF38792	BF38828	B006772	-	-	-	-
100 x 40	2500/500	2A	BF38624	BF38632	BF38644	BF29400	BE44712	BF38698	BE44714	BF38746	BF38766	BF38794	BF38830	BF38862	B005734	-	-	-
100 x 45	3000/500	2A	B004668	BF38634	BF38646	BF38666	BF38674	BF38700	BF38716	BF38748	BF38768	BF38796	BF38832	BF38864	B005736	-	-	-
120 x 40	3000/500	2A	B006822	-	BF38648	BF29406	BF38676	BF38702	BF38714	BF38750	BF38770	BF38798	BF38834	BF38866	B007058	-	-	-
125 x 40	3000/500	2A	-	-	B006826	-	BF38678	-	BF38716	B006830	B006832	BF38800	B006834	BF38868	-	-	-	-
125 x 45	4100/500	2A	-	BF38636	BF38650	-	BE44718	BF38704	BE44720	BF38752	BF38772	BF38802	BF38836	BF38870	BF38892	-	-	-
80 x 40	2000/500	2B	B004670	B005950	BF38652	-	BF38680	B005936	BF38718	-	B006902	-	-	-	-	-	-	-
100 x 35	1900/500	2B	-	-	B004748	-	B004786	-	B004786	-	-	-	-	-	-	-	-	-
100 x 40	2500/500	2B	BF38626	BF38638	BF38654	-	BF38682	BF38706	BF38720	B004842	BF38774	BF38804	BF38838	BF38872	B005032	-	-	-
100 x 45	3000/500	2B	-	-	B004704	-	B004758	B006858	B004796	-	B004864	BF38804	B004952	B006758	B006862	-	-	-
120 x 40	3000/500	2B	-	-	BF38656	-	B004754	BF38708	BF38722	B006872	BF38776	B006874	B006876	-	-	-	-	-
125 x 45	4100/500	2B	-	-	B004756	-	B004756	-	BF38724	B006888	B004866	B006890	BF38840	BF38874	BF38900	-	-	-
100 x 45	3000/500	3A	-	-	BF38684	-	BF38684	B006914	BF38726	B004844	B004868	BF38806	BF38842	B004990	B005036	-	-	-
100 x 50	3900/500	3A	-	-	BF38686	-	BF38686	B006920	BF38728	B006922	B004870	BF38808	B004956	BF38876	BF38902	-	-	-
120 x 50	4500/500	3A	-	-	B004710	-	B004764	B006750	B004802	B006782	B004872	B004910	B004958	B004994	B005040	-	-	-
125 x 45	4100/500	3A	-	-	BF38658	-	BF38688	BF38710	BE44722	BF38754	BF38778	BF38810	BF38844	BF38878	BF38904	-	-	-
125 x 50	5000/500	3A	-	BF38640	B004714	B004768	B004768	B007040	BF38730	BF38756	BF38780	BF38812	BF38846	BF38880	BF38920	-	-	-
130 x 60	7200/500	3A	-	-	B006936	-	B004772	-	B004812	B004852	B004882	B004968	B004968	B005004	B005050	-	-	-
150 x 50	5800/500	3A	-	-	BF38660	-	BF38690	-	BF38732	B004850	BF38782	BF38814	BF38848	BF38882	BF38908	-	-	-
150 x 60	7000/600	3A	-	-	B006754	-	B004774	-	B004810	-	B004880	B004918	B004966	B005002	B005048	-	-	-
100 x 50	3900/500	3B	-	-	B006944	-	-	-	B004814	B006948	B004884	B004922	B004970	B006950	B006952	-	-	-
125 x 45	4100/500	3B	-	-	BF38662	-	BF38692	-	BF38734	BF38758	BF38784	BF38816	BF38850	BF38884	B005052	-	-	-
125 x 50	5000/500	3B	-	-	-	-	-	-	B004818	B004856	B004888	B004926	B004974	B005008	B005054	-	-	-
150 x 50	5800/500	3B	-	-	-	-	-	-	BF38736	B004858	B004890	BF38818	BF38852	BF38886	BF38910	-	-	-
130 x 60	7200/500	4A	-	-	-	-	-	-	B004824	B006982	B004892	B004932	B004978	B005014	B005060	-	-	-
150 x 50	5000/600	4A	-	-	-	-	-	-	BF38738	B006986	BF38780	BF38820	BF38854	B005016	B005062	-	-	-
150 x 60	7000/600	4A	-	-	-	-	-	-	BF38740	BF38760	BF38786	BF38822	BF38856	BF38888	BF38912	-	-	-
150 x 65	8220/600	4A	-	-	-	-	-	-	B004822	-	-	B004930	-	B005012	B005058	-	-	-
150 x 70	9000/600	4A	-	-	-	-	-	-	BF38742	B007008	BF38788	BF38824	BF38858	BF38890	BF38914	-	-	-
200 x 60	9200/600	4A	-	-	-	-	-	-	B004832	-	-	B004940	B006740	B005022	B005068	-	-	-
200 x 70	12000/600	4A	-	-	-	-	-	-	B006810	-	-	B006816	B005954	B005024	B005070	-	-	-
150 x 50	5000/600	4B	-	-	-	-	-	-	B004834	-	-	B004942	B007052	B005026	CC18702	-	-	-
150 x 60	7000/600	4B	-	-	-	-	-	-	B004836	-	-	B004944	B006790	B005028	B005072	-	-	-
200 x 50	6500/600	4B	-	-	-	-	-	-	B004838	-	-	-	-	-	-	-	-	-
200 x 60	9200/600	4B	-	-	-	-	-	-	B004840	-	-	B004946	-	B005030	B006804	-	-	-

RHF

2500 kg
4500 kg

Reach forks

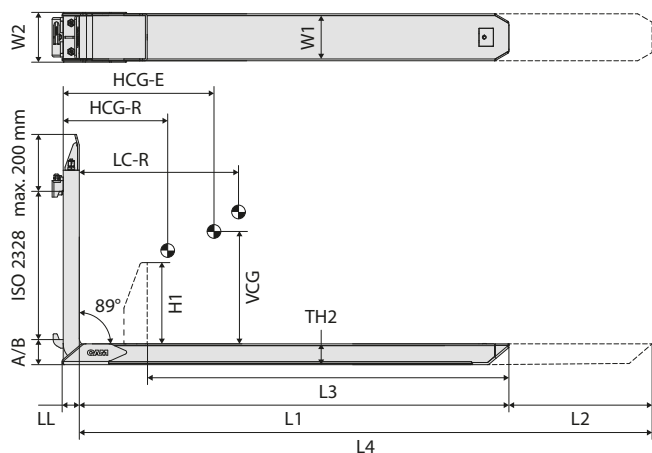

Product info

- L3 – dimension measured from fork top to pallet stop
- Telescopic forks supplied with external flow divider and 4 hoses
- Minimum oil flow: 8 l/min
- Recommended oil flow: 15 l/min
- Maximum oil flow: 25 l/min
- Minimum operating pressure: 160 bar
- Recommended operating pressure: 180 bar
- Maximum operating pressure: 250 bar
- Oil fittings size: metric 12L



Model	Capacity/pair on load centre – retracted kg/mm	L3 mm	L4 mm	W1 mm	W2 mm	TH2 mm	L1 mm	L2 mm	H1 mm	LL mm	HCG-R mm	HCG-E mm	Weight/ pair kg	ISO 2328	RRP
															Euro
Without palletstop															
CC31652	2500/600	–	1200	131	139	58	1000	200	–	45	343	380	142	2A	On request
CC31654	2500/600	–	1850	131	139	58	1100	750	–	45	385	542	149	2A	On request
CC31656	2500/600	–	2000	131	139	58	1200	800	–	45	430	601	159	2A	On request
CC31658	2500/600	–	2050	131	139	58	1200	850	–	45	430	612	159	2A	On request
CC31660	2500/600	–	2350	131	139	58	1350	1000	–	45	499	718	173	2A	On request
CC31662	3000/600	–	1200	131	139	58	1000	200	–	45	343	380	142	2A	On request
CC31664	3000/600	–	1850	131	139	58	1100	750	–	45	385	542	149	2A	On request
CC31666	3000/600	–	2000	131	139	58	1200	800	–	45	430	601	159	2A	On request
CC31668	3000/600	–	2050	131	139	58	1200	850	–	45	430	612	159	2A	On request
CC31670	3000/600	–	2350	131	139	58	1350	1000	–	45	499	718	173	2A	On request
CC31672	3500/600	–	1200	131	139	63	1000	200	–	50	346	386	144	2A	On request
CC31674	3500/600	–	1850	131	139	63	1100	750	–	50	389	558	152	2A	On request
CC31676	3500/600	–	2000	131	139	63	1200	800	–	50	434	618	161	2A	On request
CC31678	3500/600	–	2050	131	139	63	1200	850	–	50	434	629	161	2A	On request
CC31680	3500/600	–	2350	131	139	63	1350	1000	–	50	503	738	176	2A	On request
CC31682	3500/600	–	1200	131	139	63	1000	200	–	50	324	361	155	3A	On request
CC31684	3500/600	–	1850	131	139	63	1100	750	–	50	365	522	162	3A	On request
CC31686	3500/600	–	2000	131	139	63	1200	800	–	50	409	581	172	3A	On request
CC31688	3500/600	–	2050	131	139	63	1200	850	–	50	409	591	172	3A	On request
CC31690	3500/600	–	2350	131	139	63	1350	1000	–	50	476	697	187	3A	On request
CC31692	4500/600	–	1850	161	169	58	1100	750	–	45	402	554	217	3A	On request
CC33152	4500/600	–	2000	161	169	58	1200	800	–	45	447	619	229	3A	On request
CC31694	4500/600	–	2050	161	169	58	1200	850	–	45	447	621	229	3A	On request
CC31696	4500/600	–	2350	161	169	58	1350	1000	–	45	514	722	247	3A	On request

Available on request

- Camera system
- Load backres)
- Extra hardened 5 mm plate welded to the underside of the outer forks to prevent wear

Reach forks

RHF

2500 kg
4500 kg

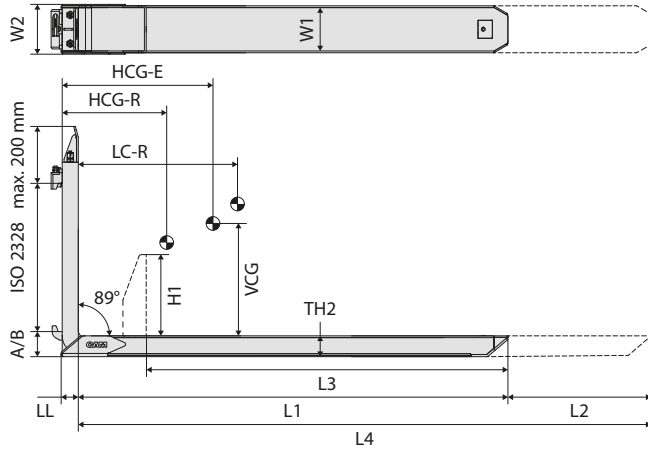

Product info

- L3 – dimension measured from fork top to pallet stop
- Telescopic forks supplied with external flow divider and 4 hoses
- Minimum oil flow: 8 l/min
- Recommended oil flow: 15 l/min
- Maximum oil flow: 25 l/min
- Minimum operating pressure: 160 bar
- Recommended operating pressure: 180 bar
- Maximum operating pressure: 250 bar
- Oil fittings size: metric 12L



Model	Capacity/pair on load centre – retracted kg/mm	L3 mm	L4 mm	W1 mm	W2 mm	TH2 mm	L1 mm	L2 mm	H1 mm	LL mm	HCG-R mm	HCG-E mm	Weight/ pair kg	ISO 2328	RRP
															Euro
With palletstop															
CC31698	2500/600	1000	1850	131	139	58	1100	750	400	45	374	557	156	2A	On request
CC31700	2500/600	1150	2000	131	139	58	1200	800	400	45	416	613	166	2A	On request
CC31702	2500/600	1150	2050	131	139	58	1200	850	400	45	416	625	166	2A	On request
CC31704	2500/600	1150	2350	131	139	58	1350	1000	400	45	489	737	180	2A	On request
CC31706	2500/600	1200	2350	131	139	58	1350	1000	400	45	491	740	180	2A	On request
CC31708	3000/600	1000	1850	131	139	58	1100	750	400	45	374	557	156	2A	On request
CC31710	3000/600	1150	2000	131	139	58	1200	800	400	45	416	613	166	2A	On request
CC31712	3000/600	1150	2050	131	139	58	1200	850	400	45	416	625	166	2A	On request
CC31714	3000/600	1150	2350	131	139	58	1350	1000	400	45	489	737	180	2A	On request
CC31716	3000/600	1200	2350	131	139	58	1350	1000	400	45	491	740	180	2A	On request
CC31718	3500/600	1000	1850	131	139	63	1100	750	400	50	371	562	161	2A	On request
CC31720	3500/600	1150	2000	131	139	63	1200	800	400	50	413	618	171	2A	On request
CC31722	3500/600	1150	2050	131	139	63	1200	850	400	50	413	632	171	2A	On request
CC31724	3500/600	1150	2350	131	139	63	1350	1000	400	50	486	746	186	2A	On request
CC31726	3500/600	1200	2350	131	139	63	1350	1000	400	50	488	749	186	2A	On request
CC31728	3500/600	1000	1850	131	139	63	1100	750	400	50	355	515	169	3A	On request
CC31730	3500/600	1150	2000	131	139	63	1200	800	400	50	396	592	179	3A	On request
CC31732	3500/600	1150	2050	131	139	63	1200	850	400	50	396	605	179	3A	On request
CC31734	3500/600	1150	2350	131	139	63	1350	1000	400	50	467	716	193	3A	On request
CC31736	3500/600	1200	2350	131	139	63	1350	1000	400	50	468	718	193	3A	On request
CC31738	4500/600	1000	1850	161	169	58	1100	750	400	45	354	513	206	3A	On request
CC33150	4500/600	1150	2000	161	169	58	1200	800	400	45	395	572	218	3A	On request
CC31740	4500/600	1150	2050	161	169	58	1200	850	400	45	395	577	218	3A	On request
CC31742	4500/600	1150	2350	161	169	58	1350	1000	400	45	466	683	236	3A	On request
CC31744	4500/600	1200	2350	161	169	58	1350	1000	400	45	467	685	236	3A	On request

Available on request

- Camera system
- Load backrest (see page 20)
- Extra hardened 5 mm plate welded to the underside of the outer forks to prevent wear

IFORKS-32 weighing forks



- **IFORKS – 32 2500 FEM 2**

REF [165TA2874](#)

- **IFORKS – 32 3000 FEM 3**

REF [164TA8627](#)

- **IFORKS – 32 5000 FEM 3**

REF [164TA8631](#)

Advantages

- Installed in 5 minutes
- Totally wireless with Bluetooth
- Power forks with compact Li-ion battery packs
- Digital calibration
- Tip or side load warning
- Easy to install in combination with fork positioners
- Efficient energy management
- Tested for 1 million cycles, at 125% capacity
- Automatic compensation in case of mast tilt

Standard specifications

- Capacity: 2500 kg; 3000 kg; 5000 kg
- Multi-range scale
 - 1–2 kg at 2500 kg
 - 1–2 kg at 3000 kg
 - 2–5 kg at 5000 kg
- Max. inaccuracy: 0.1% of the load lifted
- Dual colour display (green/red), digit height 20 mm, with backlight, 5 digits
- Red display in case of errors during tip or side loading (weight on one fork)
- Signal transfer through Bluetooth 4.0
- Controls: 4 function buttons, on/off button
- Protection class: IP65
- Housing dimensions: 60 x 77 x 182 mm (excl. bracket)

Functions

- Automatic and manual zero-point adjustment
- Gross/net weighing
- Adding function with sequential numbering
- ID code entry (5 digits)
- Integrated tilt correction in the forks
- Internal clock for date and time recording
- RS232 port for printer connection as a standard
- Bluetooth 4.0 for RAVAS WeightsApp
- Optional: WiFi or Bluetooth module for data communication
- Tip loading error message during weighing
- Sleep mode for forks with automatic start
- Resistant to 200% overload on the mechanical structure (in compliance with ISO 2330)

Power supply

- Each fork has its own rechargeable Li-ion 3.7 V / 5.2 Ah battery pack. Autonomy 75 hours continuous use. Charger station included.
- The indicator is powered by four AA batteries. Autonomy approx. 50 hours of continuous use. Optional power supply via the machine battery (reduced autonomy with data connection options)
- Sleep function with automatic start-up for the fork transmitters, and automatic shut-off function for the indicator
- The operator can customize the power setting of the indicator in the user menu.

Weighing carriages

ICP-32

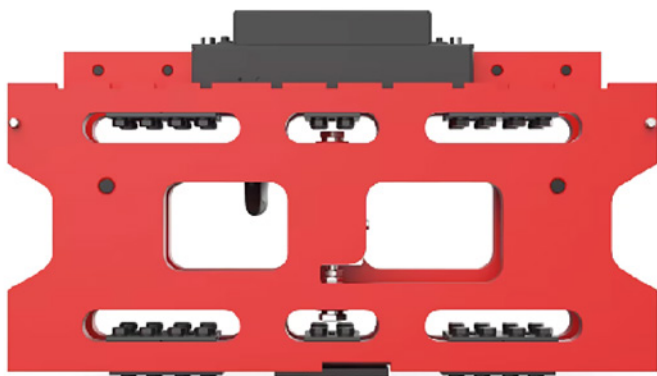

- **ICP32 – 2500 FEM 2**

REF [167TA9698](#)

- **ICP32 – 5000 FEM 3**

REF [167TA9699](#)

- **ICP32 – 7000 FEM 4**

REF [167TA9700](#)

Benefits

- Robust truck scale, for heavy-duty applications
- Total front plate width available for weighing
- Wired or wireless connection between indicator and iCP
- Can also weigh in combination with rotators and clamps
- Optional: legal for trade version
- RAVAS WeightsApp for data collection on tablets and smartphones
- Top quality for industrial use

Standard specifications

- Capacity: 2500, 5000 or 7000 kg
- Graduation
 - 2 kg at 2500 kg capacity
 - 5 kg at 5000 kg capacity
 - 10 kg at 7000 kg capacity
- Max. inaccuracy: 0.2% of the load lifted
- Overload protection: 200% on mechanical construction, in compliance with ISO 2330
- Protection class: IP65 / NEMA 4
- Power supply from machine battery, via regulator

Functions

- Automatic and manual zero-point adjustment
- Gross/net weighing
- Adding function with sequential numbering
- ID-code entry (5 digits)
- Integrated level switch (wired) or integrated level sensor (wireless)
- Internal clock for date and time recording
- RS232 port for printer connection
- Bluetooth 4.0 for RAVAS WeightsApp
- Wireless sleep mode for forklifts with automatic start
- Optional with a printer

Connection between plate and indicator

- Wireless
- Bluetooth as a standard

EXT

Fork extension – closed bottom

Product info

- Material thickness: 6 mm up to fork section 150 x 50 mm
- Material thickness: 8 mm starting from fork section 150 x 60 mm
- Supplied with locking pin

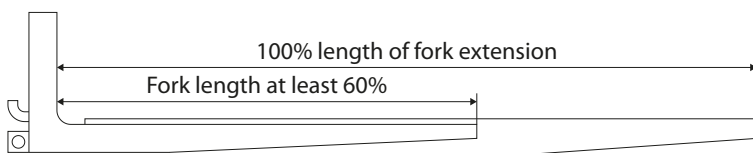

Fork section W1 x T1	REF length of fork extension								
mm	1200 mm	1400 mm	1500 mm	1600 mm	1800 mm	2000 mm	2200 mm	2400 mm	2500 mm
80 x 40	BE68072	BE68098	BE68124	BE68150	BE68176	BE68202	BE68228	BE68254	BE68280
100 x 40	BE68074	BE68100	BE68126	BE68152	BE68178	BE68204	BE68230	BE68256	BE68282
100 x 45	BE68078	BE68104	BE68130	BE68156	BE68182	BE68208	BE68234	BE68260	BE68286
100 x 50	BE68076	BE68102	BE68128	BE68154	BE68180	BE68206	BE68232	BE68258	BE68284
120 x 40	BG06500	BG06504	BG06508	BG06512	BG06516	BG06520	BG06524	BG06528	BG06532
120 x 50	BE68080	BE68106	BE68132	BE68158	BE68184	BE68210	BE68236	BE68262	BE68288
125 x 40	BE68082	BE68108	BE68134	BE68160	BE68186	BE68212	BE68238	BE68264	BE68290
125 x 45	BE68084	BE68110	BE68136	BE68162	BE68188	BE68214	BE68240	BE68266	BE68292
125 x 50	BG19716	BG19718	BG19720	BG19722	BF33930	BG19724	BG19726	BG19728	BG19730
130 x 45	BE68086	BE68112	BE68138	BE68164	BE68190	BE68216	BE68242	BE68268	BE68294
130 x 50	BE68088	BE68114	BE68140	BE68166	BE68192	BE68218	BE68244	BE68270	BE68296
130 x 60	BE68090	BE68116	BE68142	BE68168	BE68194	BE68220	BE68246	BE68272	BE68298
140 x 50	BE68092	BE68118	BE68144	BE68170	BE68196	BE68222	BE68248	BE68274	BE68300
150 x 50	BE68094	BE68120	BE68146	BE68172	BE68198	BE68224	BE68250	BE68276	BE68302
150 x 60	BE68096	BE68122	BE68148	BE68174	BE68200	BE68226	BE68252	BE68278	BE68304
150 x 70	BG06502	BG06506	BG06510	BG06514	BG06518	BG06522	BG06526	BG06530	BG06534
mm	1220 mm	1370 mm	1525 mm	1829 mm	1982 mm	2134 mm	2440 mm		
100 x 50	BH18336	BH18338	BH18340	BH18342	BH18344	BG88958	BH18346		
130 x 50	BG88960	BG88962	BG88964	BG88966	BG88968	BG88970	BG88972		
150 x 60	BH18348	BH18350	BH18352	BG88976	BG88978	BG88980	BH18354		

Fork length must be at least 60%
Conforms to ISO 13284
Made in Europe

Available on request

- Other sizes

Fork extension – open bottom

EXT2

Product info

- Material thickness: 8 mm
- Supplied with locking pin

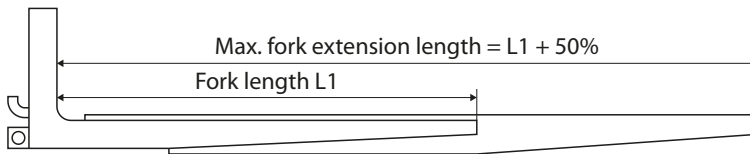

Fork section W1 x T1	REF length of fork extension								
mm	1200 mm	1400 mm	1500 mm	1600 mm	1800 mm	2000 mm	2200 mm	2400 mm	2500 mm
80 x 40	BF98760	BF98788	BF98816	BF98844	BF98872	BF98900	BG06550	BG06574	BG06598
100 x 40	BF98762	BF98790	BF98818	BF98846	BF98874	BF98902	BG06552	BG06576	BG06600
100 x 45	BF98764	BF98792	BF98820	BF98848	BF98876	BF98904	BG06554	BG06578	BG06602
100 x 50	BF98766	BF98794	BF98822	BF98850	BF98878	BF98906	BG06556	BG06580	BG06604
120 x 40	BG06536	BG06538	BG06540	BG06542	BG06544	BG06546	BG06548	BG06572	BG06596
120 x 50	BF98768	BF98796	BF98824	BF98852	BF98880	BF98908	BG06558	BG06582	BG06606
125 x 40	BF98770	BF98798	BF98826	BF98854	BF98882	BF98910	BG06560	BG06584	BG06608
125 x 45	BF98772	BF98800	BF98828	BF98856	BF98884	BF98912	BG06620	BG06622	BG06624
125 x 50	BF98774	BF98802	BF98830	BF98858	BF98886	BF98914	BG06562	BG06586	BG06610
130 x 45	BF98776	BF98804	BF98832	BF98860	BF98888	BF98916	BG06564	BG06588	BG06612
130 x 50	BF98778	BF98806	BF98834	BF98862	BF98890	BF98918	BG06566	BG06590	BG06614
140 x 50	BF98782	BF98810	BF98838	BF98866	BF98894	BF98922	BG06568	BG06592	BG06616
150 x 50	BF98784	BF98812	BF98840	BF98868	BF98896	BF98924	BG06570	BG06594	BG06618

Fork length must be at least 60%

Conforms to ISO 13284

Made in Europe

Available on request

- Other sizes

Slip-on-fork arm with rubber-faced pads

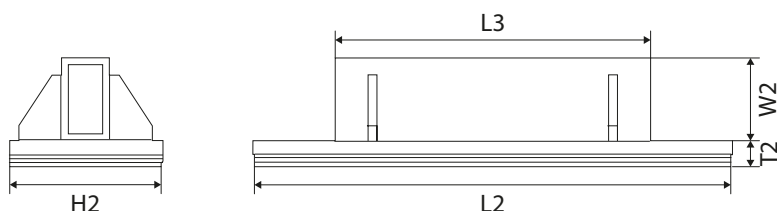

Model	Fork section W1 x T1	L2 x H2	L3	W2	T2	*	Weight	RRP
	mm	mm	mm	mm	mm	mm	kg	Euro
CPG15.1	100 x 35	900 x 300	600	120	30	80/100	70	1380
CPG15.2	100 x 35	1000 x 300	800	120	30	80/100	78	1530
CPG15.3	100 x 35	1100 x 300	850	120	30	80/100	88	1660
CPG15.4	100 x 35	1200 x 300	900	120	30	80/100	98	1790
CPG20.1	130 x 35	900 x 300	600	150	30	80/100	73	1410
CPG20.2	130 x 35	1000 x 300	800	150	30	80/100	81	1530
CPG20.3	130 x 35	1200 x 300	900	150	30	80/100	101	1790
CPG28.1	130 x 45	900 x 300	600	150	30	80/100	77	1960
CPG28.2	130 x 45	1000 x 300	800	150	30	80/100	85	2140
CPG28.3	130 x 45	1200 x 300	900	150	30	80/100	105	2360

* Reduction of the opening range with fork clamps installed
Available for different forks sizes of bales

Available on request

- Other sizes

Slip-on-fork arm for concrete blocks

CBA

Product info

- Available for different forks sizes and drums
- With hydraulic compensation
- With polyurethane contact pads

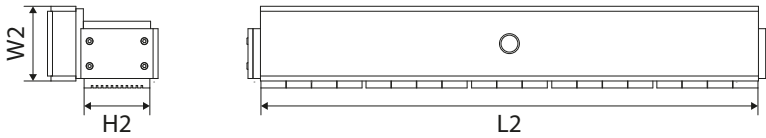

Model	Fork section W1 x T1	L2 x H2	L3	W2	T2	*	Weight	RRP
	mm	mm	mm	mm	mm	mm	kg	Euro
CBA20.1	130 x 35	1000 x 160	–	150	–	70	–	5040

* Reduction of the opening range with fork clamps installed

Available on request

- Other sizes

CF

Slip-on-fork arm for drums

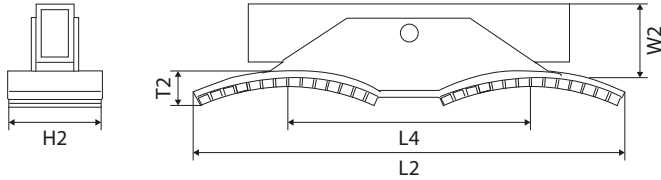

Model	Fork section W1 x T1	L2 x H2	Drums	L4	W2	T2	*	Weight	RRP
	mm	mm	mm	mm	mm	mm	mm	kg	Euro
CF15	100 x 35	450 x 220	1/2	–	120	105	80/100	35	1410
CF20	130 x 35	450 x 220	1/2	–	150	105	80/100	36	1510
CF28	130 x 45	450 x 220	1/2	–	150	105	80/100	38	1510
CF15.1	100 x 35	1050 x 220	2/4	610	120	60	80/100	85	2560
CF20.1	130 x 35	1050 x 220	2/4	610	150	60	80/100	89	2810
CF28.1	130 x 45	1050 x 220	2/4	610	150	60	80/100	100	2810

* Reduction of the opening range with fork clamps installed
Available for different forks sizes and drums

Available on request

- Other sizes

Anti-slip coating

COA



Secure, anti-slip fork coating

Applications

- To handle slippery loads such as metal cages or plastic boxes
- To protect loads against damage and scratches during transportation

Features

- Coating thickness: approx. 5 mm
- Shore hardness: 92 shore A
- Abrasion resistance: 140 mg in compliance with ASTM D 1044
- Tensile strength: 21 N/mm²
- Operating temperature: -40 to 80 °C
- Coating of fork blade and/or fork back
- Permanently attached to the fork
- Protective plate on fork tip

Advantages

- Increased safety by eliminating the risk of slippery loads
- Slip resistance in both wet and dry conditions
- Noise reduction, so particularly useful when transporting metal parts in residential areas and at night
- Protects goods from damage or scratches, for example when transporting without pallets (provides protection in the fork back and heel area)
- Abrasion and cut resistance for optimum use and a long life
- High flexibility: available and retrofittable for many different sizes and applications
- Fast delivery

Interested?

Please contact your sales advisor!

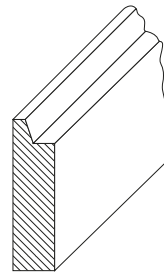
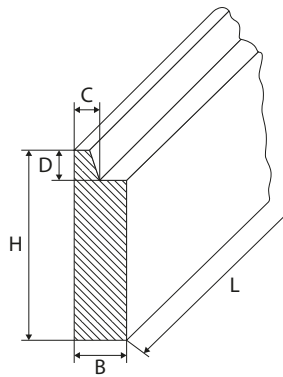

1

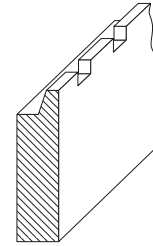

2

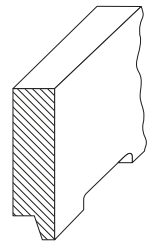

3

Class	H	B	C	D	REF	REF	REF
FEM	mm	mm	mm	mm	Profile 1	Top profile 2	Bottom profile 3
2	60	50,0	16,0	13	124TA1939	124TA1940	124TA1941
2	80	30,0	16,0	13	111TA3753	111TA3754	111TA3755
2	110	32,0	16,0	13	107TA4832	107TA4793	107TA4811
2	110	38,0	16,0	13	107TA4833	107TA4794	107TA4812
2	127	32,0	16,0	13	107TA4834	107TA4795	107TA4813
2	150	38,0	16,0	13	107TA4835	107TA4796	107TA4814
2	152	32,0	16,0	13	107TA4836	107TA4797	107TA4815
3	148	40,0	21,5	16	107TA4837	107TA4798	107TA4816
3	180	38,0	21,5	16	107TA4838	107TA4799	107TA4817
3	180	45,0	21,5	16	107TA4839	107TA4800	107TA4818
4	180	57,0	25,5	19	107TA4840	107TA4801	107TA4819

Class	H	B	C	D	Length	REF	REF
FEM	mm	mm	mm	mm	mm	Top profile	Bottom profile
2	100	40,0	16,0	13	1000	111TA6026	111TA6030
2	100	40,0	16,0	13	1200	111TA6027	111TA6031
3	150	40,0	21,5	16	1000	111TA6028	111TA6032
3	150	40,0	21,5	16	1200	111TA6029	111TA6033

Notes

A series of horizontal dotted lines for writing notes.

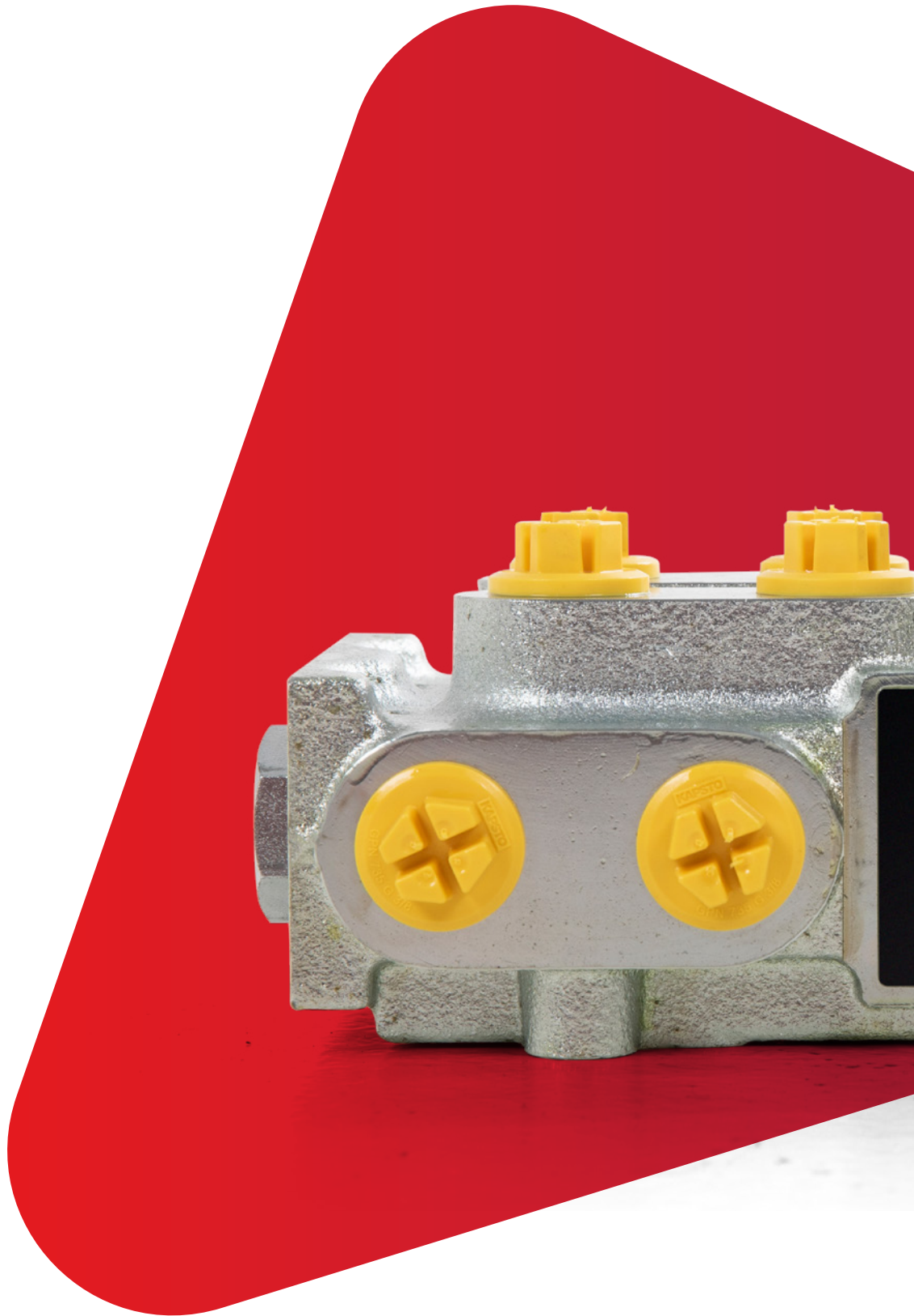

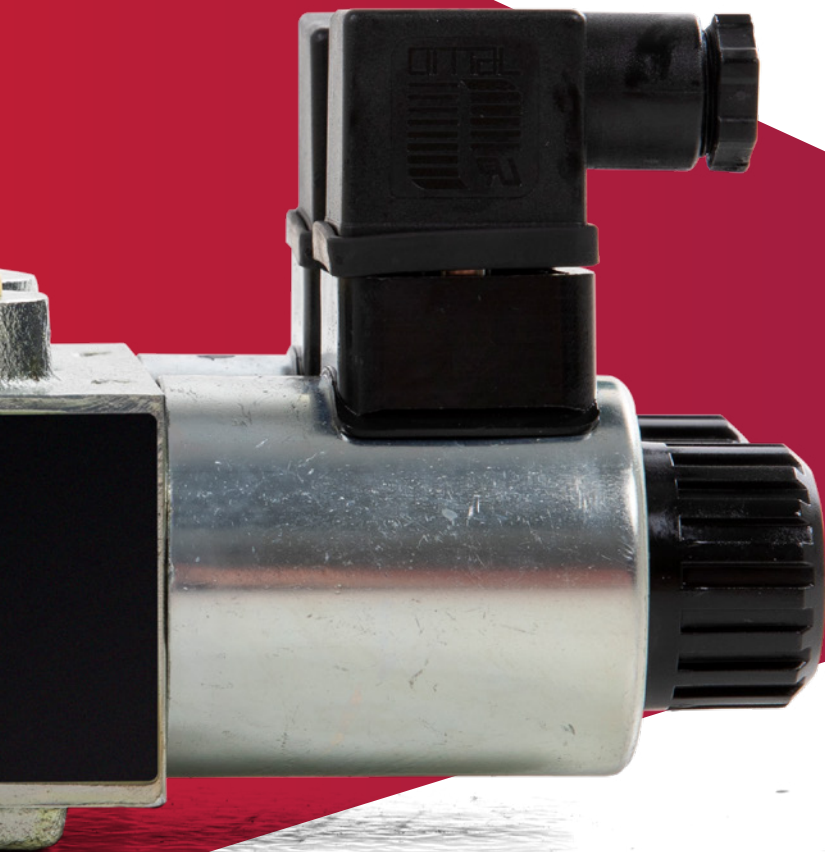

24. Options, accessories and hydraulic parts

We also offer other relevant products to equip attachments with the right components, add functionality to the machine and help you get the job done.

Wireless fork camera system



Features

- Multiple languages: English, Dutch, French, Spanish, Russian, German, Italian
- 10–15 hours battery life
- Split mode, auto-scan mode and single display mode are available
- Automatic pairing when the camera is activated
- Support 4-channel composite and single-channel recording in AVI signal format
- Automatic switch to working channel when the trigger is activated
- Fork camera with built-in magnetic base

Included

- 1 x 7" wireless HD monitor
- 1 x wireless HD forkcamera
- 1 x 15 h battery pack
- 1 x battery charger

REF [166TA1385](#)

Recommended optional items



Spare camera

REF [166TA1397](#)



Battery pack

REF [152TA1643](#)

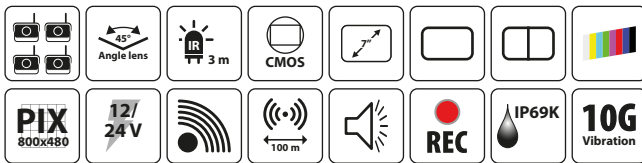

Open control valve

OCV

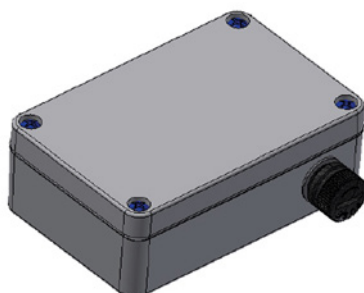

Features

- CAM attachments® Open control valve provides an added level of security to prevent accidental load dropping
- In the event that the opening lever is operated accidentally, the CAM attachments® open control valve prevents the opening of the arms of the equipment

Code and price

[V152.12.KIT.C](#)

Price on request

Included

- Valve complete with body, cartridge, solenoid 12 V
- Junction box for relay and fuse holder
- Illuminated green button

Optional items

- Current converter DC-DC: 80 V-12 V

DD

Digital dynamometer



Features

- The HE.DN CAM attachments® dynamometer is an instrument designed and manufactured for measuring the distribution of clamping force on equipment used in the handling of cartons and household appliances

Included

- Digital testing unit with integrated printer
- Portable testing frame

Code and price

[HE.DN](#)

Price on request

Pressure control

PC

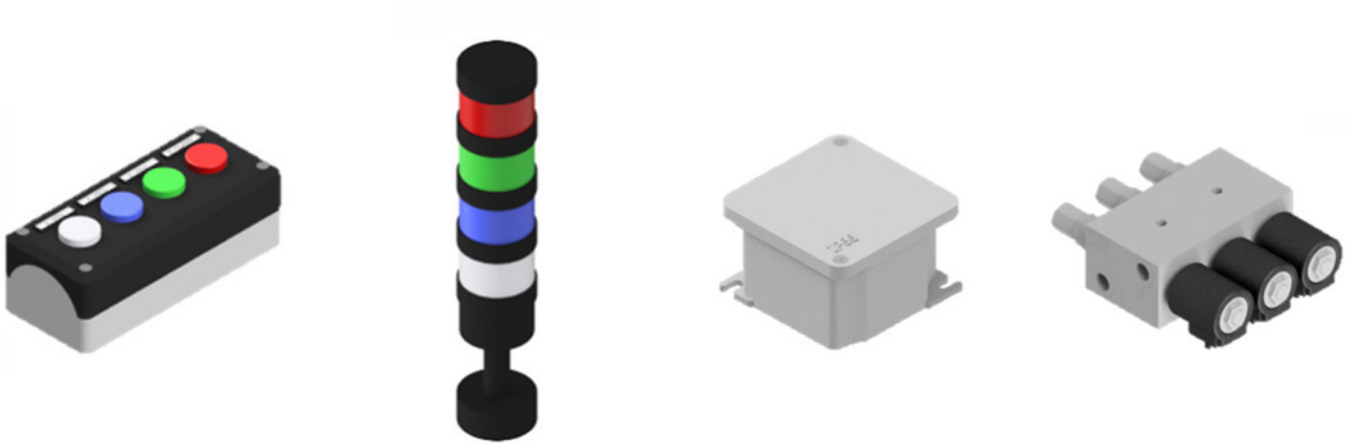

Features

- CAM attachments® pressure control allows you to select between 4 preset and adjustable pressures which allow you to adjust the clamping force of the equipment depending on the load requirements

Code and price

[PC.HE.EV.24V](#)

Price on request

Included

- Keypad
- Light column
- Control board box
- Maximum pressure valve

Optional items

- Current converter DC – DC 80 V – 24 V

STD

Dynamometer

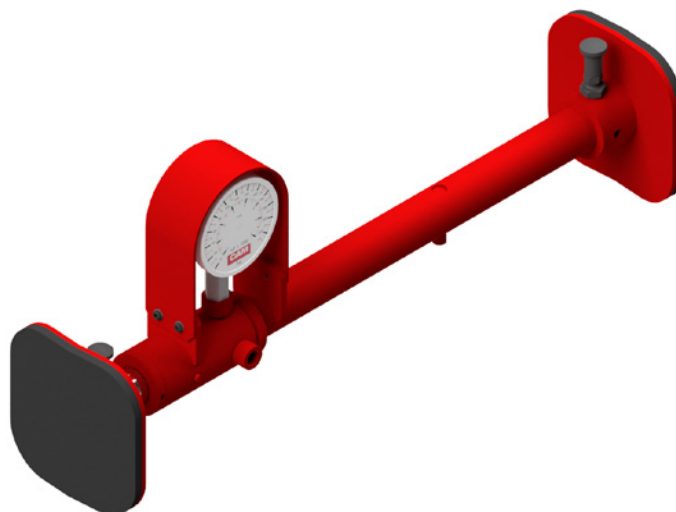

Features

- CAM attachments® dynamometer can be used for calibrating clamping strength for optimal performance relating to individual loads. Additionally it can also be used in testing and inspection situations. Available with or without frame the equipment is perfect for all testing scenarios.

Code and price

[SHC.50](#)

Price on request

Included

- SHC.50 Dynamometer 0–7000 kg

Optional items

- Portable testing frame

Add-on prices for other fork dimensions

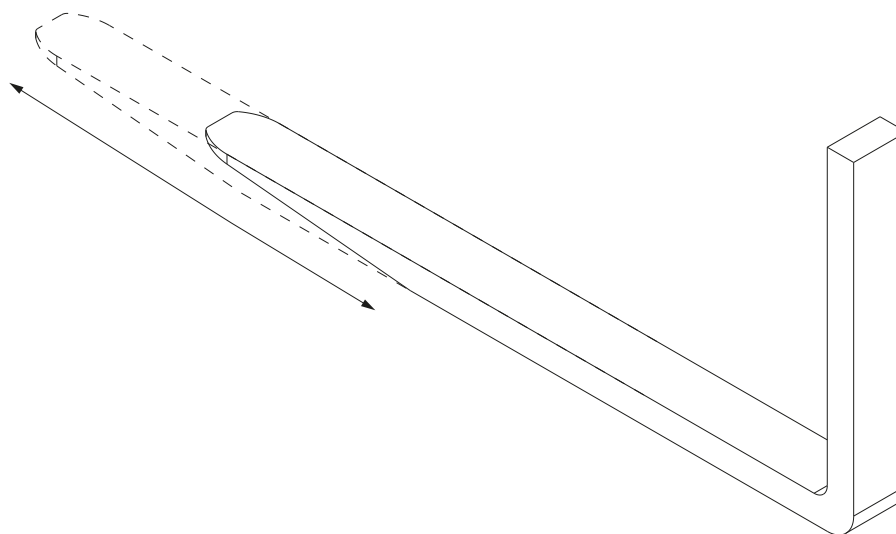

Capacity

kg

0–1500

1500–2500

2500–3500

3500–5000

5000–8000

Set quick-release lower mountings

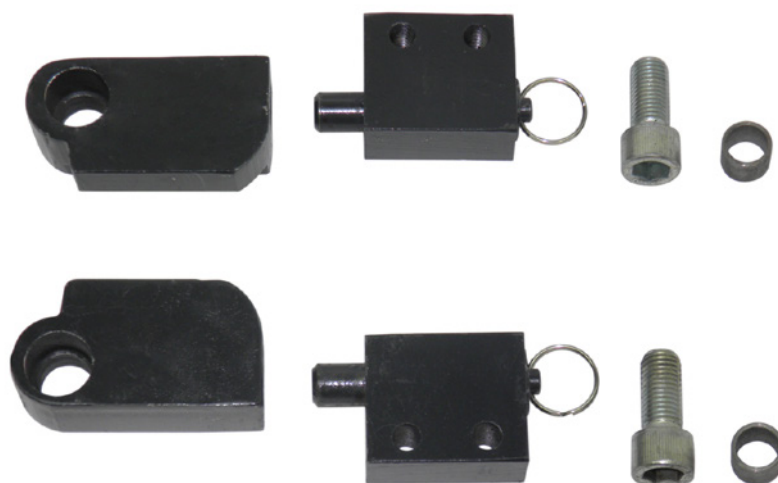

**Only in combination with clamps.
Not applicable for e.g. sidershifters, buckets, etc.**

**Interested?
Please contact your sales advisor!**

Hydraulic valves and components

VAL

Valves for direct in-line mounting with general-purpose threaded connections

Due to the variety of operating conditions and applications for these products, it is important that you analyse all aspects of your application before selecting or using one. As a user, you are solely responsible for the final selection of the products and systems after analysing and testing. You must also ensure that the application's environmental requirements are met.

Valve block manifold for sideshifting clamps

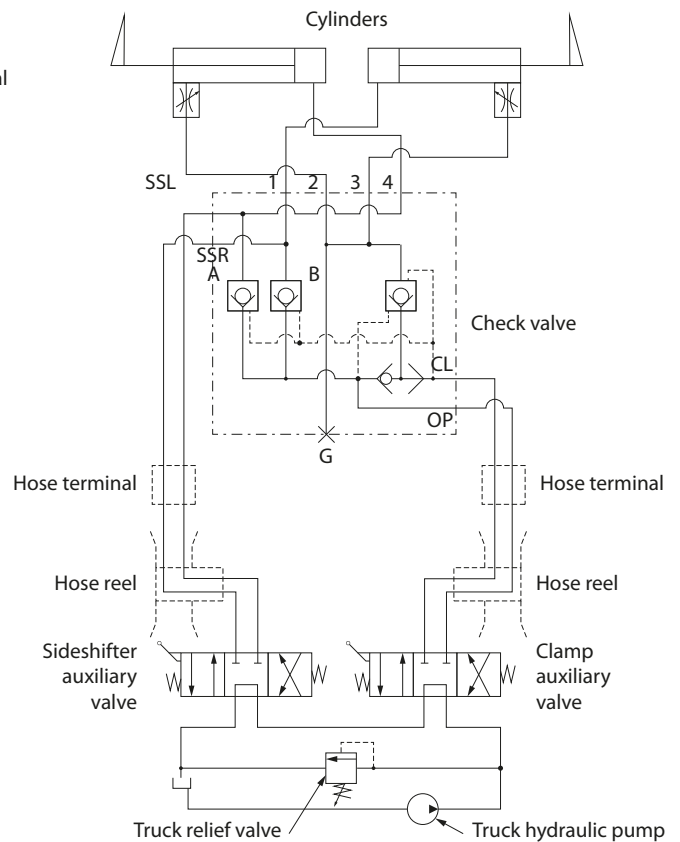
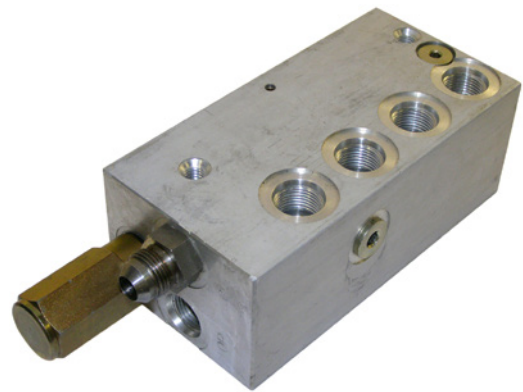
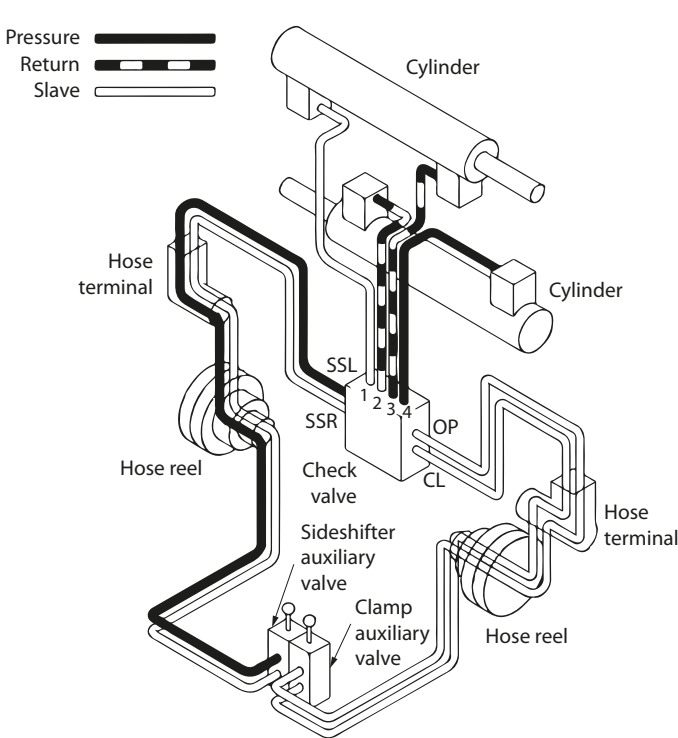

- Connections: CL, OP, 1, 2, 3, 4: 3/4–16 UNF
- G, SSL, SSR: 9/16–18 UNF
- Pressure: 110–160 bar
- Min. flow: 19 l/min
- Regulated flow 38 l/min
- Max. flow: 45 l/min

REF [133TA7812](#)

Pressure relief valve for manual selection of 3 different pressures



- Mechanical version
- With change-over switch
- 3 pressures
- Up to 200 bar
- Connections: M18 x 1,5

HD = 50–200 bar
 MD = 30–180 bar
 ND = 0–150 bar

REF [134TA2336](#)

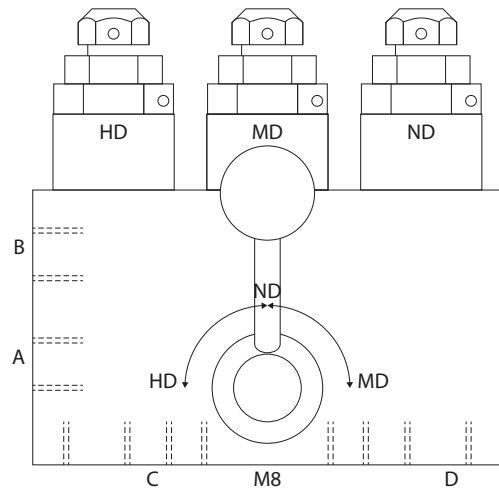
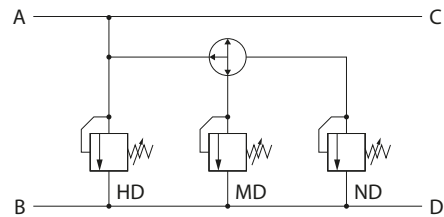

Pressure relief valve for pressure selection by solenoid control

Pressure relief valve with change-over switch used on paper roll clamps (3 pressures)

- Adjustable 30–180 bar with flow 45 l/min
- With a flow of 10 l/min = max. pressure 150–160 bar
- The valve is regulated at 140 bar with flow 30 l/min

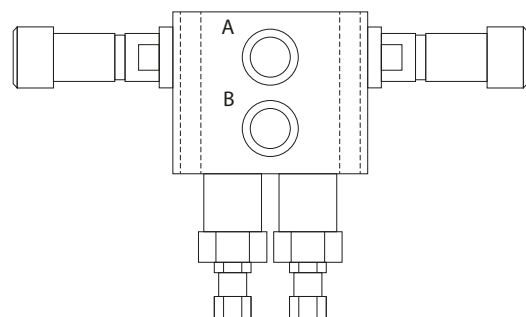
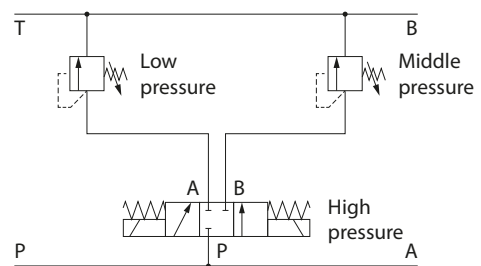
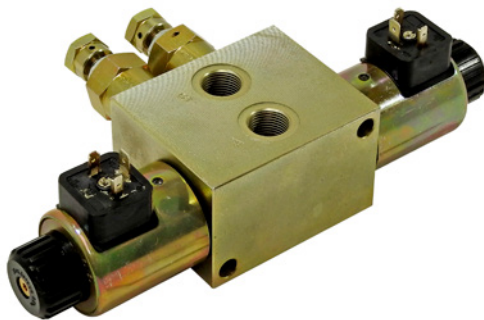

- **With electro valve 12 V**
- Connections: M18 x 1,5
- Pressure: 210 bar
- Flow: 50 l/min

REF [133TA9275](#)

- **With electro valve 24 V**
- Connections: M18 x 1,5
- Pressure: 210 bar
- Flow: 50 l/min

REF [133TA9276](#)

Throttle valves used on forklift attachment

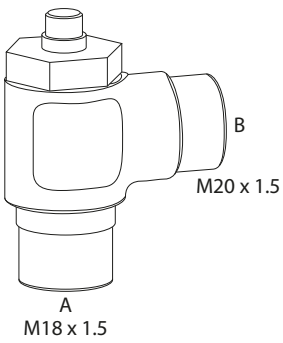

Execution: 1

REF [133TA9277](#)

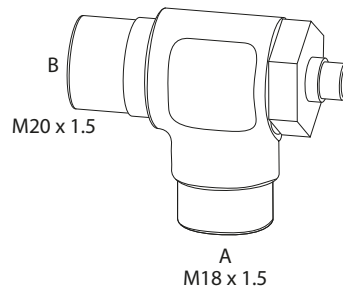
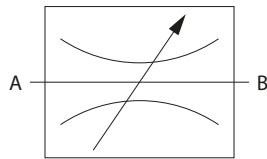





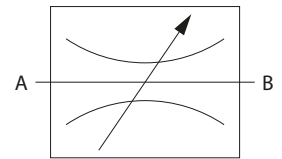

Execution: 2

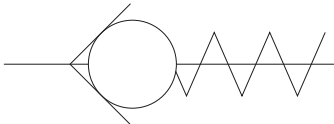
REF [133TA9278](#)

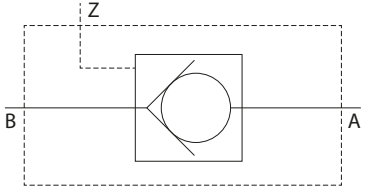

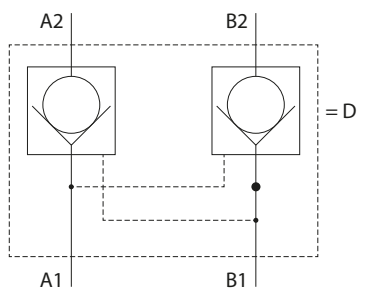
Check valves

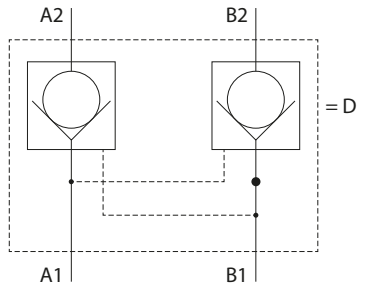
	Flow	Ports	REF
 	<p>16 l/min. 30 l/min. 50 l/min. 90 l/min.</p>	<p>G1/4" G3/8" G1/2" G3/4"</p>	<p>127TA3836 140TA9077 140TA9078 140TA9079</p>
 		<p>Port A, B = G3/8" Port Z = G1/4"</p>	<p>127TA3841</p>
 		<p>Threaded connections = G1/4"</p>	<p>127TA3840</p>
 		<p>Threaded connections = G3/8"</p>	<p>127TA3842</p>

Single-ball shuttle valves

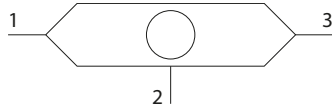
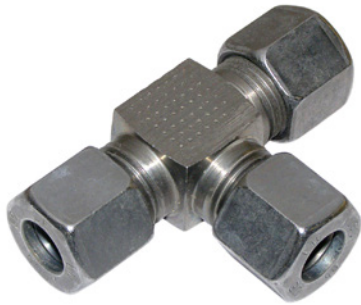

- With signal at port 2
- Max. pressure 250 bar
- Used for load sensing signal
- Connections: M16 x 1,5

REF [133TA9270](#)

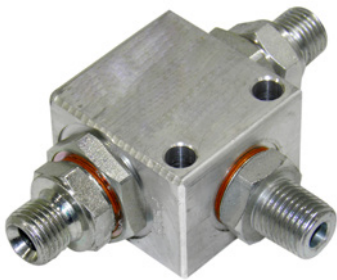

- Connections: 3 x 1/4" BSP

REF [152TA1983](#)

Pressure relief valve for paper roll clamp

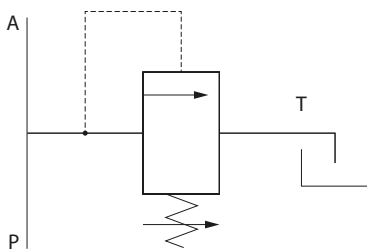

	Flow	Pressure	Ports	REF
	80 l/min.	250 bar	P/A/T 3/4" BSP	133TA7804
	30 l/min.	350 bar	P/A/T 1/2" BSP	133TA7836

Flow control valves

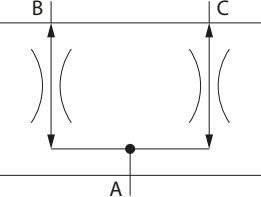

Flow divider – combiner

	Min. flow rate	Max. flow rate	Ports	Max. pressure range	Dividing	REF
	8 l/min.	20 l/min.	G3/8	350	50:50	127TA3850
	13 l/min.	25 l/min.	G3/8	300	50:50	140TA9080
	26 l/min.	40 l/min.	1 x 1/2" BSP + 2 x 3/8" BSP	300	50:50	140TA9081

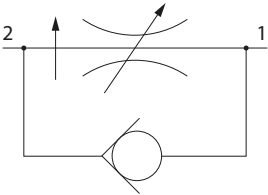
2 ways pressure compensated flow valve







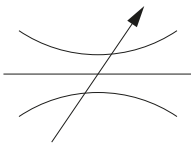

	Min. flow	P max.	Ports	REF
	18 l/min.	250 bar	3/8" BSP	131TA9098
	33 l/min.	250 bar	1/2" BSP	163TA8517

3 ways, pressure compensated flow valve

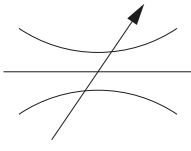

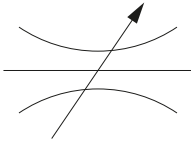

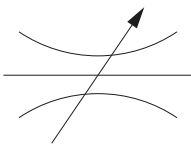

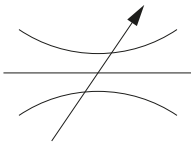

	Regulated flow	Max. flow	P max	Ports	REF
	0–25 l/min.	40 l/min.	300 bar	3/8" BSP	152TA1986
	2–50 l/min.	90 l/min.	300 bar	1 port: 3/4" BSP 2 ports: 1/2" BSP	152TA1987

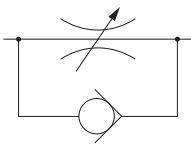
Throttle valves

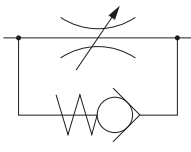
Types without bypass

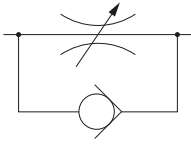
		Flow	Pressure	Ports	REF
		25 l/min.	210 bar	1/4" BSP	133TA7811
		30 l/min.	400 bar	3/8" BSP	152TA1990
		40 l/min.	200 bar	1/2" BSP	134TA2335
		80 l/min.	250 bar	3/4" BSP	133TA7805
		200 l/min.	320 bar	1" BSP	133TA7808

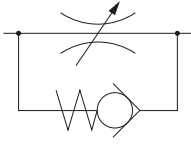
Types with bypass

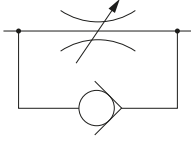
		Min. flow	P max	Ports	REF
		15 l/min.	400 bar	1/4" BSP	152TA1991
		30 l/min.	200 bar	3/8" BSP	133TA7807
		40 l/min.	200 bar	1/2" BSP	133TA7809
		60 l/min.	345 bar	1/2" BSP	133TA7806
		95 l/min.	210 bar	3/4" BSP	133TA7810

Directional valves



For all directional valves below:

- Type NG-6
- 350 bar
- 70 l/min.

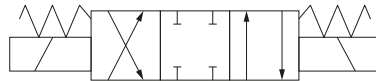
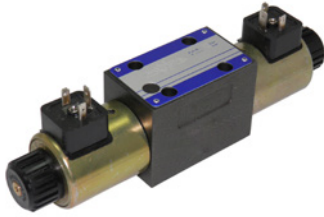

REF [131TA9514](#) – 12 VDC

REF [131TA9515](#) – 24 VDC

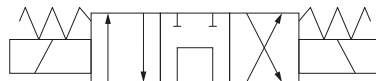
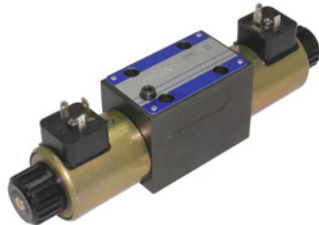

REF [131TA9516](#) – 12 VDC

REF [131TA9517](#) – 24 VDC

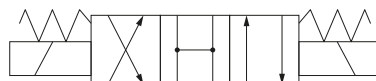
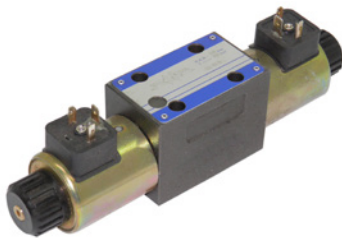

REF [131TA9518](#) – 12 VDC

REF [131TA9519](#) – 24 VDC

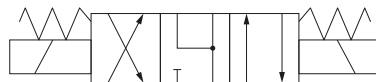
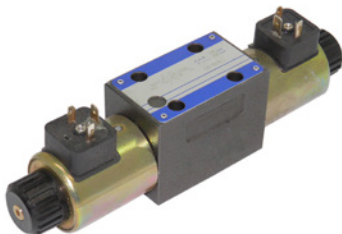

REF [131TA9520](#) – 12 VDC

REF [131TA9521](#) – 24 VDC

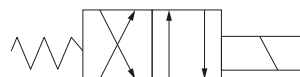

REF [152TA1977](#) – 12 VDC

REF [152TA1978](#) – 24 VDC

Directional valves

2/2-way

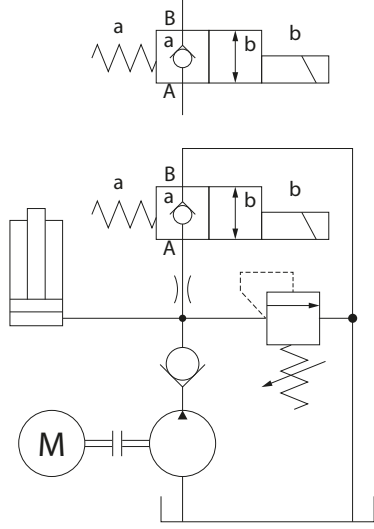
	Voltage	Ports	REF
	12 VDC	Threaded connections: G3/8"	127TA3843
	24 VDC	Threaded connections: G3/8"	127TA3844

6/2-way

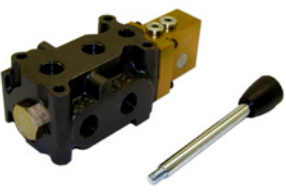
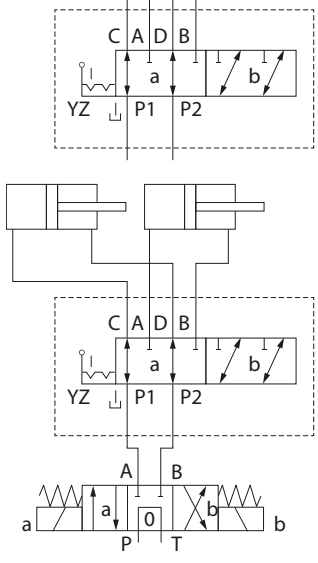
	Voltage	Ports	REF
	Manual operation	G3/8"	127TA3845
			

Electrical valve to double the working functions on one lever (universal application)

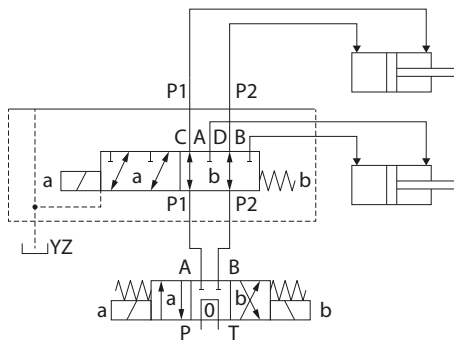
	Voltage	Ports	REF
	12 V 24 V 48 V 80 V	G3/8"x	106TA6818 106TA6819 106TA6820 111TA5832
		Mounting and lever kit	106TA6821

Directional valves

3/2-way

Voltage	Ports	REF
12 VDC	G3/8"	127TA3846
24 VDC	G3/8"	127TA3847

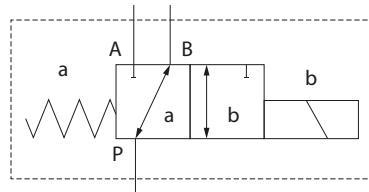

8/3-way

Voltage	Ports	REF
12 VDC	G3/8"	127TA3848
24 VDC	G3/8"	127TA3849

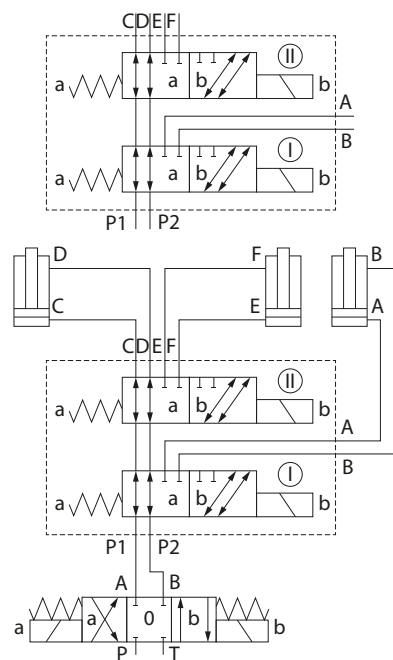

Aluminium parallel multiple manifolds – lateral ports with relief valve

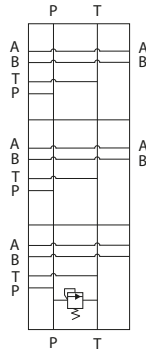

Aluminium manifold can be used for pressures up to 210 bar (3000 PSI)

Ports:

- P-T: BSPP 1/2"
- M: BSPP 1/4" (measure point)
- A-B: BSPP 3/8"

REF [152TA1979](#)

Base plate NG6-CETOP 3



Ports:

- 3/8" BSP

REF [152TA1980](#)

Electrical connector



REF [152TA1981](#)

Coverplate NG6

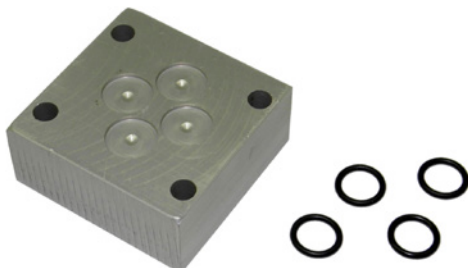

REF [152TA1982](#)

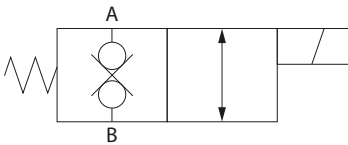
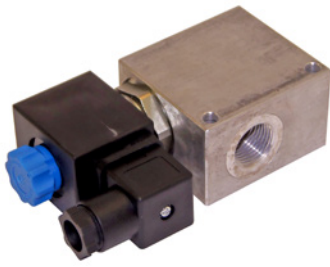

1. Poppet 2-way double lock normally closed

Voltage	Ports	Max. flow	P max.	REF
		l/min.	bar	
12VDC	G 1/2"	70	350	133TA7813
24VDC	G 1/2"	70	350	133TA7814

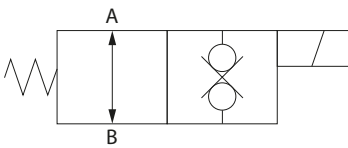

2. Poppet 2-way double lock normally open

Voltage	Ports	Max. flow	P max.	REF
		l/min.	bar	
12VDC	G 1/2"	70	350	133TA7835
24VDC	G 1/2"	70	350	133TA7815

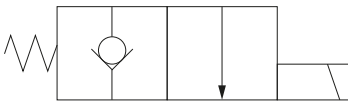

3. Poppet type, normally closed

Voltage	Ports	Max. flow	P max.	REF
		l/min.	bar	
12VDC	G 3/8"	23	207	152TA2007
24VDC	G 3/8"	23	207	152TA2008

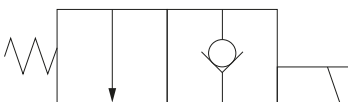

4. Poppet type, normally open

Voltage	Ports	Max. flow	P max.	REF
		l/min.	bar	
12VDC	G 3/8"	23	207	163TA8267
24VDC	G 3/8"	23	207	152TA2010

Hose burst valves

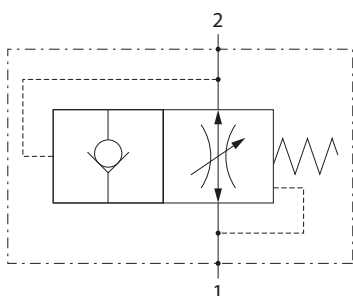
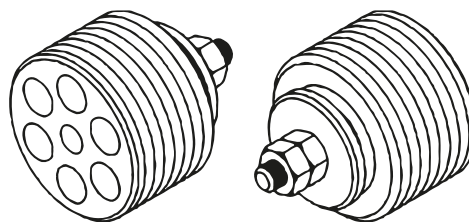

GAS	Max. flow	Max. pressure	REF
	l/min.	bar	
1/4"	25	350	152TA1993
3/8"	50	350	152TA1995
1/2"	80	350	152TA1996
3/4"	150	350	152TA1997



Special tool for fitting hose burst valves

GAS	REF
3/8"	152TA2001
1/2"	152TA1999
3/4"	152TA1998

Hydraulic distributor

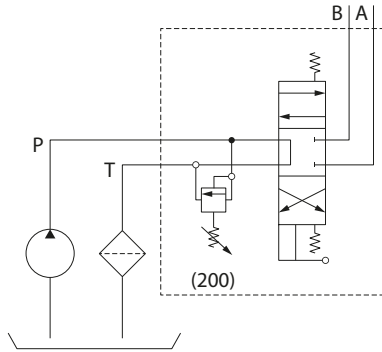

- Ports: G 3/8" BSP
- Max. flow: 35 l/min

REF [106TA6806](#)

Hydraulic distributor

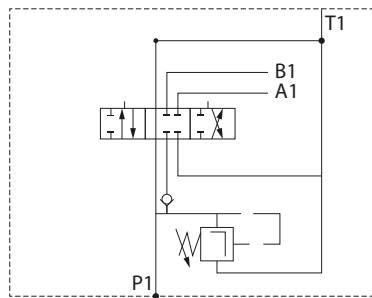

- Ports: G 3/8" BSP
- Max. flow: 35 l/min

REF [152TA2003](#)

Hydraulic distributor with microswitch

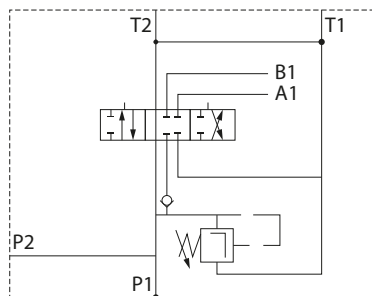

- Ports: 3/8" BSP
- Max. flow: 35 l/min

REF [152TA2005](#)

Hydraulic distributor

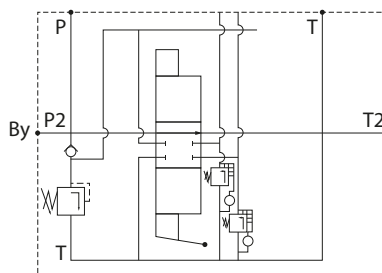

- Connections: P, A, B = G 3/4" BSP
- T = G1
- Inclusive carry over plug G1
- Max. flow: 120 l/min
- P max: 250 bar/inclusive carry over plug

REF [163TA8519](#)

Rapid ext log splitter valve

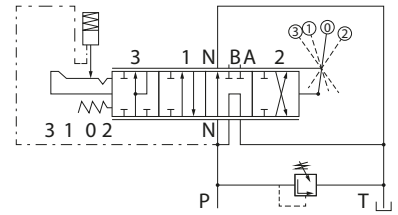
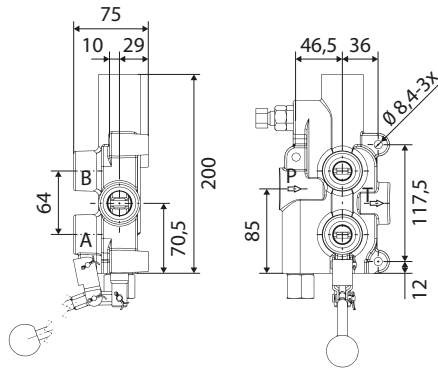

REF [152TA2011](#) – Ports: 1/2" BSP

2-way ball valves

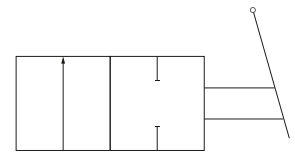
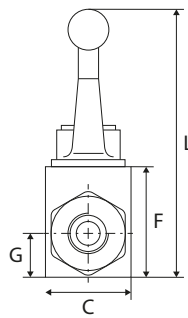
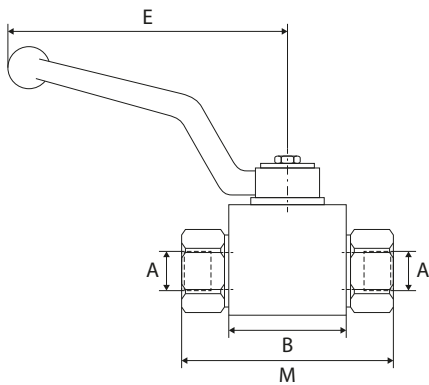

Ports	REF
1" BSP	152TA2039
1/2" BSP	152TA2040
3/8" BSP	152TA2041
1/4" BSP	152TA2042

3-way ball valves

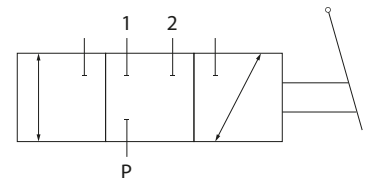
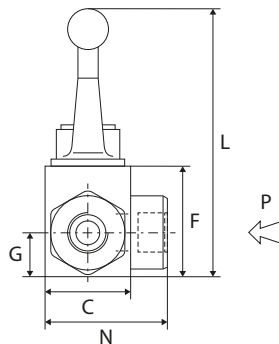
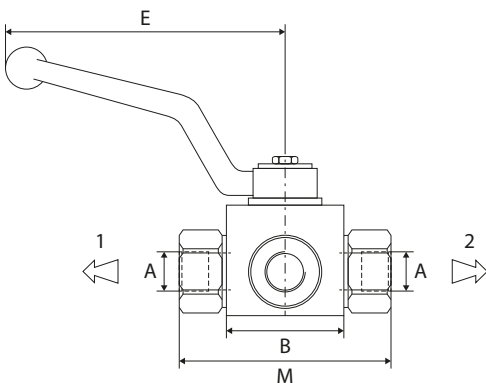

Ports	REF
1" BSP	152TA2749
3/4" BSP	152TA2748
1/2" BSP	152TA2747
3/8" BSP	152TA2746

All dimensions in mm

RLS

Universal kit with hydraulic hose reel for extra functionality

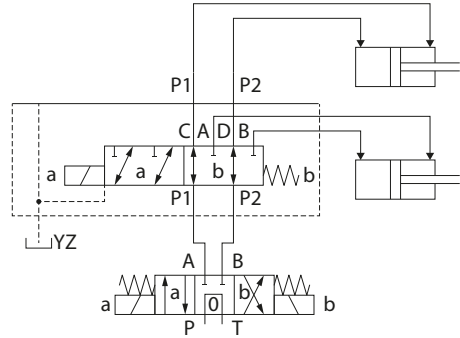
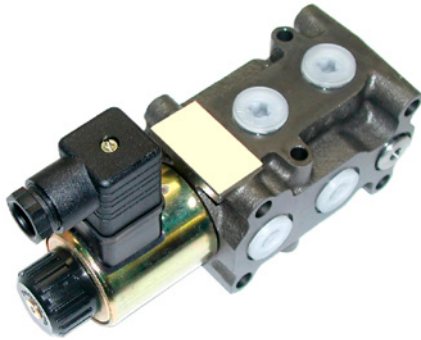

Technical data

Type	REF 3/8" BSP	REF 1/2" BSP
6/2 valve 12 V	106TA6818	161TA5963
6/2 valve 24 V	106TA6819	161TA5964
6/2 valve 48 V	106TA6820	161TA5965
6/2 valve 80 V	111TA5832	161TA5966

Switch



REF [146TA6446](#)

Swivel



REF [135TA9669](#)

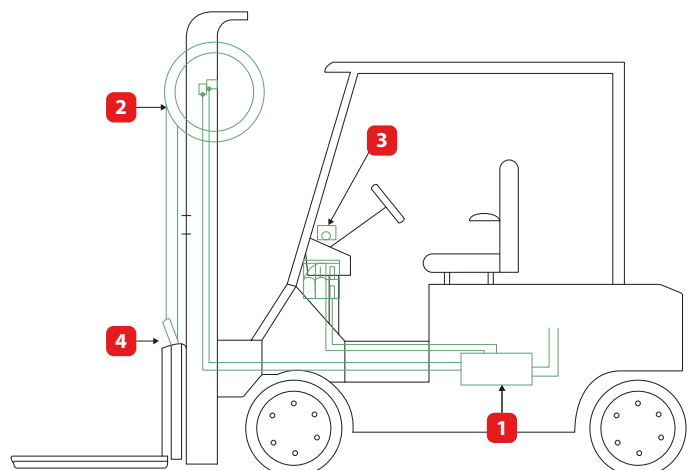

1. 6/2 valve
2. Hose reel
3. Switch
4. Swivel

Hose reel and bracket

RLS2



Hose reels are an excellent alternative to internal hose installations. They contain all the components required to supply hydraulic oil to the attachment and can be installed on almost all two- or three-stage masts. A complete kit contains a reel, mounting bracket, hose and fittings.

1. Complete kit
2. Reel
3. Hose, end connection
4. Fitting
5. Mounting bracket
6. Hose reel bracket

Technical data

- Maximal lift height for duplex mast: 6.3 m
- Maximal lift height for triplex mast: 4.8 m
- Hose type: double synflex 1/4"

	Reel diameter	Max. hose length	REF	REF
	mm	m	Type RH	Type LH
1. Complete kit	280	3,91	107TA3683	107TA3684
2. Reel (without hoses)	280	3,91	107TA3678	107TA3679
3. Hose, end connection 9/16" JIC	280	3,91	107TA3681	107TA3681
4. Fitting (4 required)	280	3,91	107TA3680	107TA3680
5. Mounting bracket	280	3,91	107TA3682	107TA3682
6. Hose reel bracket	280	3,91	161TA5785	161TA5786

Technical data

- Maximal lift height for duplex mast: 7.1 m
- Maximal lift height for triplex mast: 5.5 m
- Hose type: double synflex 3/8"

	Reel diameter	Max. hose length	REF	REF
	mm	m	Type RH	Type LH
1. Complete kit	330	4,57	107TA3676	107TA3677
2. Reel (without hoses)	330	4,57	107TA3673	107TA3674
3. Hose, end connection 9/16" JIC	330	4,57	107TA3675	107TA3675
4. Fitting (4 required)	330	4,57	107TA3668	107TA3668
5. Mounting bracket	330	4,57	107TA3670	107TA3670
6. Hose reel bracket	330	4,57	161TA5785	161TA5786

Technical data

- Maximal lift height for duplex mast: 13 m
- Maximal lift height for triplex mast: 9.81 m
- Hose type: double synflex 3/8"

	Reel diameter	Max. hose length	REF	REF
	mm	m	Type RH	Type LH
1. Complete kit	410	7,62	107TA3671	107TA3672
2. Reel (without hoses)	410	7,62	107TA3666	107TA3667
3. Hose, end connection 9/16" JIC	410	7,62	107TA3669	107TA3669
4. Fitting (4 required)	410	7,62	107TA3668	107TA3668
5. Mounting bracket	410	7,62	107TA3670	107TA3670
6. Hose reel bracket	410	7,62	161TA5785	161TA5786

Notes

A series of horizontal dotted lines for writing notes.

Notes

A series of horizontal dotted lines for writing notes.

Notes

A series of horizontal dotted lines for writing notes.

Notes

A series of horizontal dotted lines for writing notes.

Looking for other attachments?

Visit [camattachments.com](https://www.camattachments.com) to explore the full range. While there, you'll also find:

Capacity calculator

A simple tool for calculating the residual capacity of a forklift with any attachment

Technical information

Detailed products leaflets, user manuals and spare parts lists (login required)

Product videos

See our attachments in action and get a glimpse of what they can do

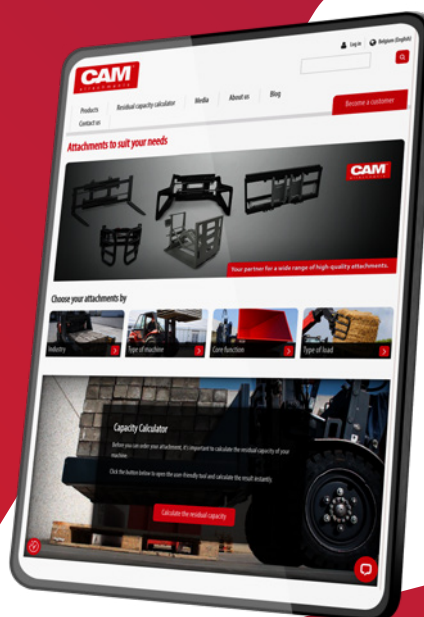

Questions?

We're here to help!

- Use the **chat function** on our website for urgent questions
- Send us your detailed queries through the **contact sheet** on our website
- Reach out to **your sales advisor**, always ready to assist

CAM attachments

Brabantstraat 15 • 8790 Waregem • Belgium

T +32 56 43 42 11 • F +32 56 43 44 88

www.camattachments.com • info@camattachments.com